

200mW, Low VF SMD Schottky Barrier Diode

FEATURES

- Designed for mounting on small surface
- Low Capacitance
- Low forward voltage drop
- Compliant to RoHS directive 2011/65/EU and in accordance to WEEE 2002/96/EC
- Halogen-free according to IEC 61249-2-21

APPLICATIONS

- Adapters
- For switching power supply
- Low stored charge
- Inverter

MECHANICAL DATA

- Case: SOT-23
- Molding compound: UL flammability classification rating 94V-0
- Moisture sensitivity level: level 1, per J-STD-020
- Packing code with suffix "G" means green compound (halogen-free)
- Terminal: Matte tin plated leads, solderable per J-STD-002
- Meet JESD 201 class 1A whisker test
- Weight: 8 mg (approximately)

KEY PARAMETERS		
PARAMETER	VALUE	UNIT
$I_{F(AV)}$	200	mA
V_{RRM}	40	V
I_{FSM}	0.6	A
V_F at $I_F=40mA$	1	V
T_J Max.	125	°C
Package	SOT-23	



ABSOLUTE MAXIMUM RATINGS ($T_A = 25^\circ\text{C}$ unless otherwise noted)						
PARAMETER	SYMBOL	BAS40	BAS40-04	BAS40-05	BAS40-06	UNIT
Marking code on the device		43	44	45	46	
Repetitive peak reverse voltage	V_{RRM}	40				V
Forward current	$I_{F(AV)}$	200				mA
Non-repetitive peak forward surge current @ $t = 8.3ms$	I_{FSM}	0.6				A
Junction temperature range	T_J	-65 to +125				°C
Storage temperature range	T_{STG}	-65 to +125				°C

THERMAL PERFORMANCE			
PARAMETER	SYMBOL	LIMIT	UNIT
Junction-to-ambient thermal resistance	$R_{\theta JA}$	357	°C/W

ELECTRICAL SPECIFICATIONS ($T_A = 25^\circ\text{C}$ unless otherwise noted)					
PARAMETER	CONDITIONS	SYMBOL	MIN	MAX	UNIT
Forward voltage per diode ⁽¹⁾	$I_F = 1\text{mA}, T_J = 25^\circ\text{C}$	V_F	-	0.38	V
	$I_F = 40\text{mA}, T_J = 25^\circ\text{C}$			1.00	
Reverse current @ rated V_R per diode ⁽²⁾	$V_R = 30\text{V}, T_J = 25^\circ\text{C}$	I_R	-	0.2	μA
Reverse Breakdown Voltage	$I_R = 10\mu\text{A}$	$V_{(BR)}$	40	-	V
Junction capacitance	1 MHz, $V_R = 1\text{V}$	C_J	-	5.0	pF
Reverse Recovery Time	$I_F = I_R = 10\text{mA}, R_L = 100\Omega,$ $I_{RR} = 1\text{mA}$	t_{rr}	-	5.0	ns

Notes:

1. Pulse test with $PW = 0.3\text{ ms}$
2. Pulse test with $PW = 30\text{ ms}$

ORDERING INFORMATION				
PART NO.	PACKING CODE	PACKING CODE SUFFIX(*)	PACKAGE	PACKING
BAS40-XX (Note 1)	RF	G	SOT-23	3K / 7" Reel

Notes:

1. "XX" is Device code from "04" to "06".

*: optional available

EXAMPLE				
EXAMPLE P/N	PART NO.	PACKING CODE	PACKING CODE SUFFIX	DESCRIPTION
BAS40-04 RFG	BAS40-04	RF	G	Green compound

CHARACTERISTICS CURVES

($T_A = 25^\circ\text{C}$ unless otherwise noted)

Fig. 1 Power Derating Curve

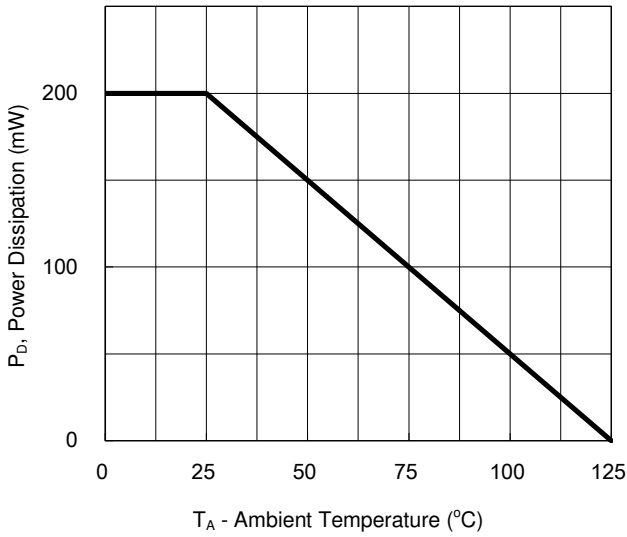

Fig.2 Maximum Non-Repetitive Peak Forward Surge Current Per Leg

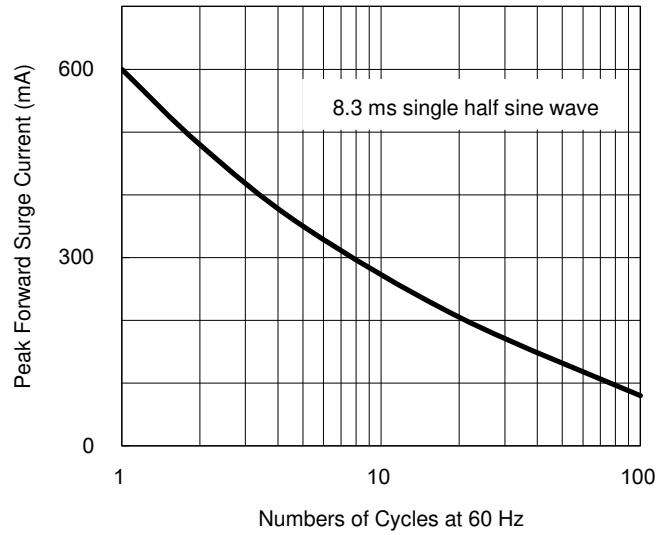

Fig.3 Typical Forward Characteristics

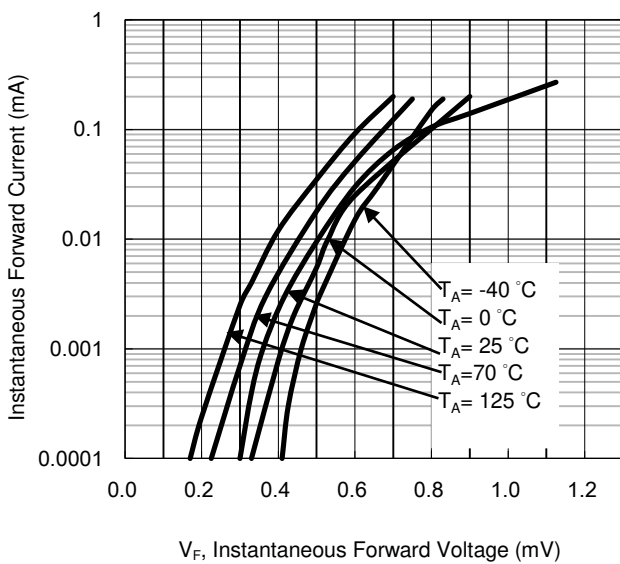
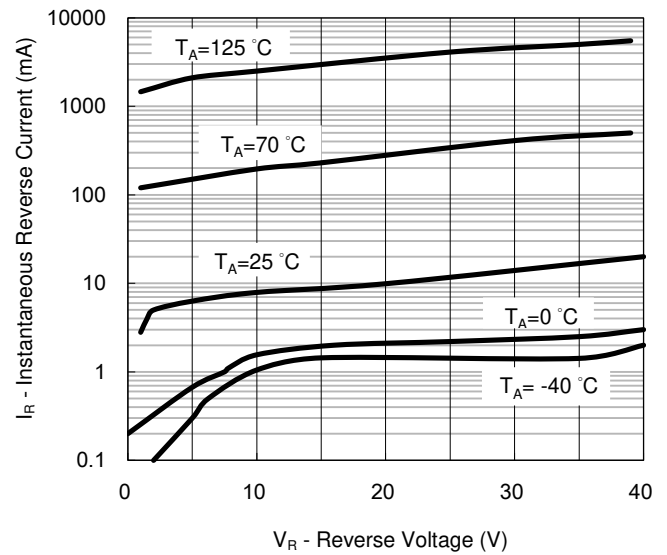

Fig.4 Typical Reverse Characteristics



CHARACTERISTICS CURVES

($T_A = 25^\circ\text{C}$ unless otherwise noted)

Fig. 5 Typical Total Capacitance VS. Reverse Voltage

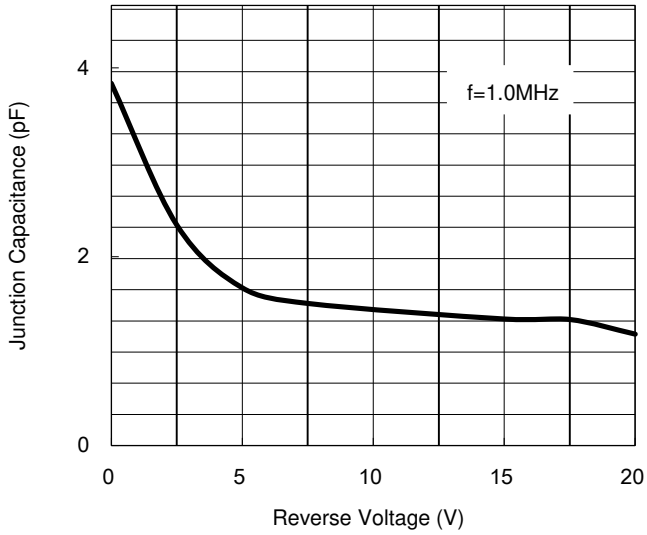
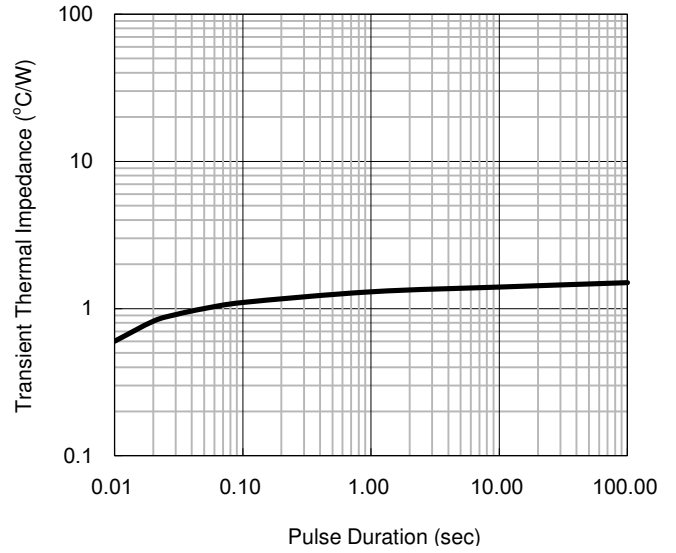
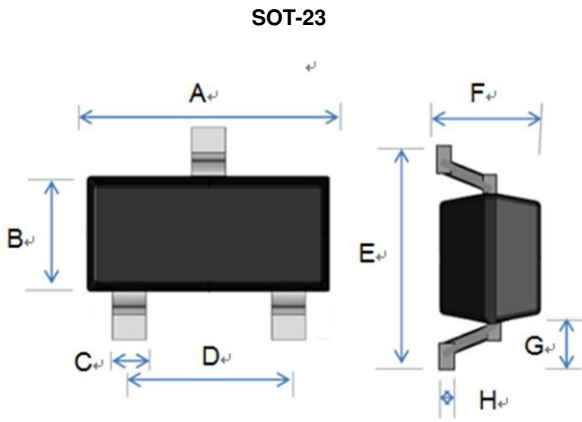

Fig.6 Typical Transient Thermal Characteristics



PACKAGE OUTLINE DIMENSION



DIM.	Unit(mm)		Unit(inch)	
	Min	Max	Min	Max
A	2.70	3.10	0.106	0.122
B	1.10	1.50	0.043	0.059
C	0.30	0.51	0.012	0.020
D	1.78	2.04	0.070	0.080
E	2.10	2.64	0.083	0.104
F	0.89	1.30	0.035	0.051
G	0.55 REF		0.022 REF	
H	0.10 REF		0.004 REF	

SUGGEST PAD LAYOUT

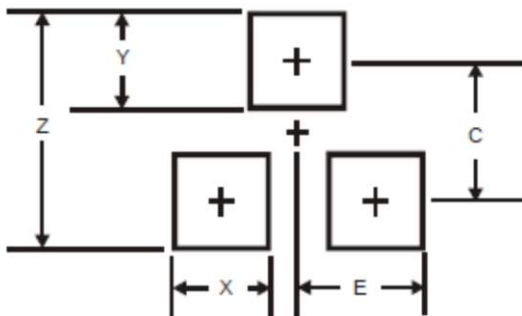

DIM.	Unit(mm)	Unit(inch)
	TYP	TYP
Z	2.8	0.11
X	0.7	0.03
Y	0.9	0.04
C	1.9	0.07
E	1.0	0.04

PIN CONFIGURATION

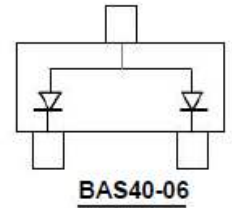
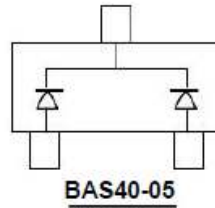
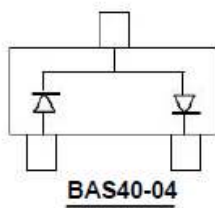
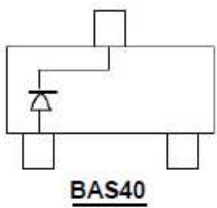

Notice

Specifications of the products displayed herein are subject to change without notice. TSC or anyone on its behalf, assumes no responsibility or liability for any errors or inaccuracies.

Information contained herein is intended to provide a product description only. No license, express or implied, to any intellectual property rights is granted by this document. Except as provided in TSC's terms and conditions of sale for such products, TSC assumes no liability whatsoever, and disclaims any express or implied warranty, relating to sale and/or use of TSC products including liability or warranties relating to fitness for a particular purpose, merchantability, or infringement of any patent, copyright, or other intellectual property right.

The products shown herein are not designed for use in medical, life-saving, or life-sustaining applications. Customers using or selling these products for use in such applications do so at their own risk and agree to fully indemnify TSC for any damages resulting from such improper use or sale.