
Features

- Direct Supply from the Mains
- Current Consumption ≤ 0.5 mA
- Very Few External Components
- Full-wave Drive – No DC Current Component in the Load Circuit
- Negative Output Current Pulse Typically 100 mA – Short-circuit Protected
- Simple Power Control
- Ramp Generator
- Reference Voltage

Applications

- Full-wave Power Control
- Temperature Regulation
- Power Blinking Switch

Description

The integrated circuit, T2117, is designed as a zero-voltage switch in bipolar technology. It is used to control resistive loads at mains by a triac in zero-crossing mode. A ramp generator allows power control function by period group control, whereas full-wave logic guarantees that full mains cycles are used for load switching.



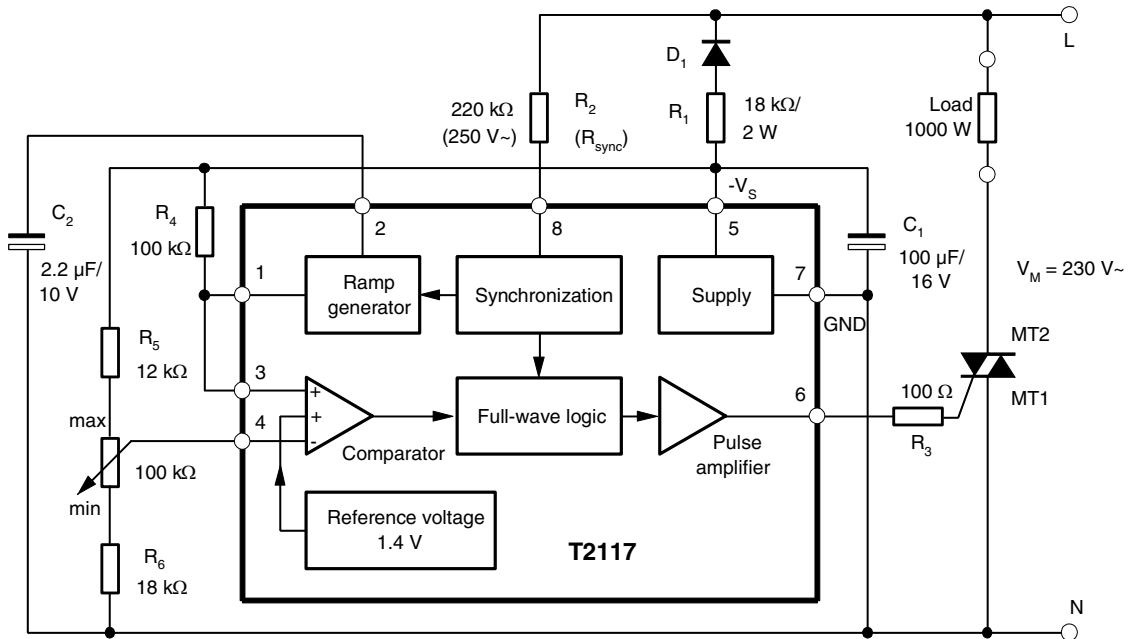
Zero-voltage Switch with Adjustable Ramp

T2117

Rev. 4768A-INDCO-11/03

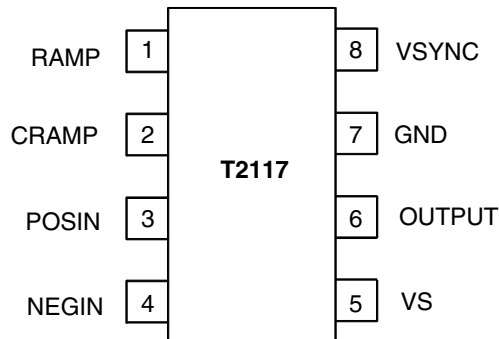


Figure 1. Block Diagram with Typical Circuit, Period Group Control 0 to 100%



Pin Configuration

Figure 2. Pinning DIP8/SO8



Pin Description

Pin	Symbol	Function
1	RAMP	Ramp output
2	CRAMP	Ramp capacitor
3	POSIN	Non-inverting comparator input
4	NEGIN	Inverting comparator input
5	VS	Supply voltage
6	OUTPUT	Trigger pulse output
7	GND	Ground
8	VSYNC	Voltage synchronization

General Description

The integrated circuit T2117 is a triac controller for zero-crossing mode. It is designed to control power in switching resistive loads of mains supplies.

Information regarding synchronous supply is provided at pin 8 via resistor R_{Sync} . To avoid a DC load on the mains, the full-wave logic guarantees that complete mains cycles are used for load switching.

A fire pulse is released when the inverting input of the comparator is negative (pin 4) with respect to the non-inverting input (pin 3) and internal reference voltage. A ramp generator with freely selectable duration can be performed by capacitor C_2 at pin 2. The ramp function is used for open-loop control (Figure 4), but also for applications with proportional band regulation (Figure 11 on page 9). Ramp voltage available at capacitor C_2 is decoupled across the emitter follower at pin 1. To maintain the lamp flicker specification, the ramp duration is adjusted according to the controlling load. One can use internal reference voltage for simple applications. In that case, pin 3 is inactive and connected to pin 7 (GND), see Figure 13 on page 11.

Figure 3. Pin 1 Internal Network

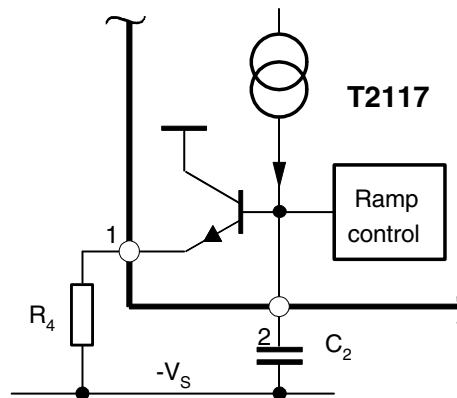
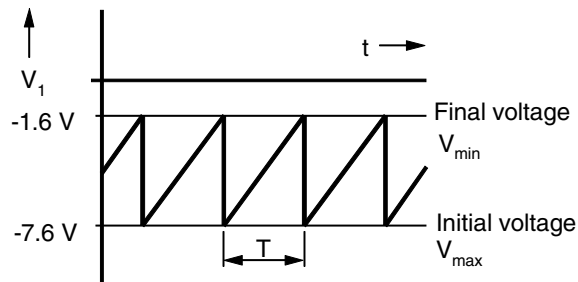


Figure 4. Threshold Voltage of the Ramp at $V_S = -8.8\text{ V}$



Triac Firing Current (Pulse)

This depends on the triac requirement. It can be limited by the gate series resistance which is calculated as follows:

$$R_{Gmax} \approx \frac{7.5 \text{ V} - V_{Gmax}}{I_{Gmax}} - 36 \Omega$$

$$I_P = \frac{I_{Gmax}}{T} \times t_p$$

where:

V_G = Gate voltage

I_{Gmax} = Maximum gate current

I_p = Average gate current

t_p = Firing pulse width

T = Mains period duration

Firing Pulse Width t_p

This depends on the latching current of the triac and its load current. The firing pulse width is determined by the zero-crossing detection which can be influenced by the synchronous resistance, R_{sync} , (see Figure 6 on page 5).

$$t_p = \frac{2}{\omega} \arcsin\left(\frac{I_L \times V_M}{P \sqrt{2}}\right)$$

where

I_L = Latching current of the triac

V_M = Mains supply, effective

P = Load power

The total current consumption is influenced by the firing pulse width which can be calculated as follows:

$$R_{sync} = \frac{V_M \sqrt{2} \sin\left(\omega \times \frac{t_p}{2}\right) - 0.6 \text{ V}}{3.5 \times 10^{-5} \text{ A}} - 49 \text{ k}\Omega$$

Figure 5. Output Pulse Width

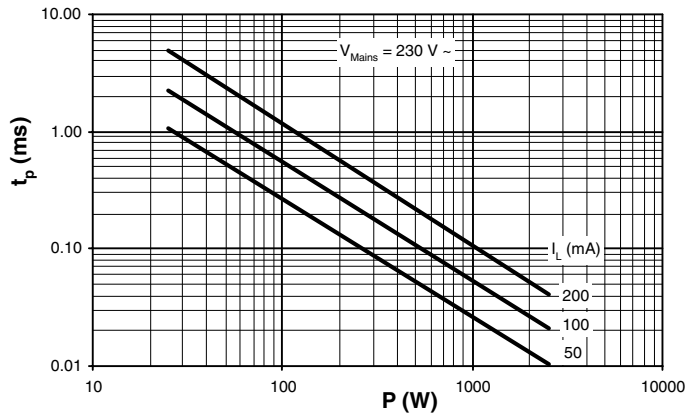
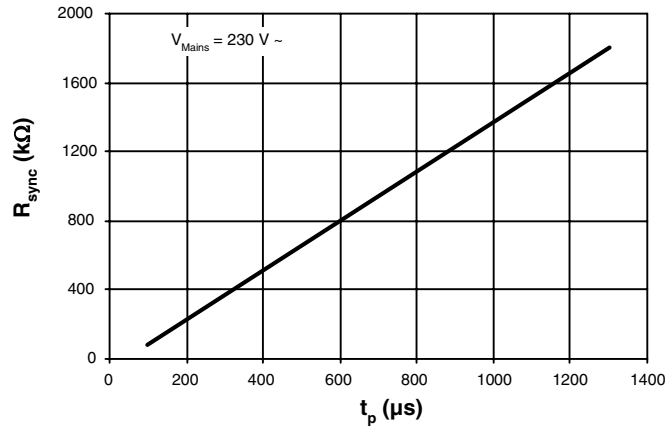


Figure 6. Synchronization Resistance



Supply Voltage

The T2117 contains a voltage limiting function and can be connected with the mains supply via the diode D_1 and the resistor R_1 . The supply voltage between pin 5 and 7 is limited to a typical value of 9.5 V.

The series resistance R_1 can be calculated as follows (Figure 7 on page 6 and Figure 8 on page 6):

$$R_{1\max} = 0.85 \frac{V_{M\min} - V_{S\max}}{2 I_{\text{tot}}}; P_{(R1)} = \frac{(V_M - V_S)^2}{2 R_1}$$

$$I_{\text{tot}} = I_S + I_P + I_x$$

where

- V_M = Mains voltage
- V_S = Limiting voltage of the IC
- I_{tot} = Total current consumption
- I_S = Current requirement of the IC (without load)
- I_x = Current requirement of other peripheral components
- $P_{(R1)}$ = Power dissipation at R_1

Figure 7. Maximum Resistance of R_1

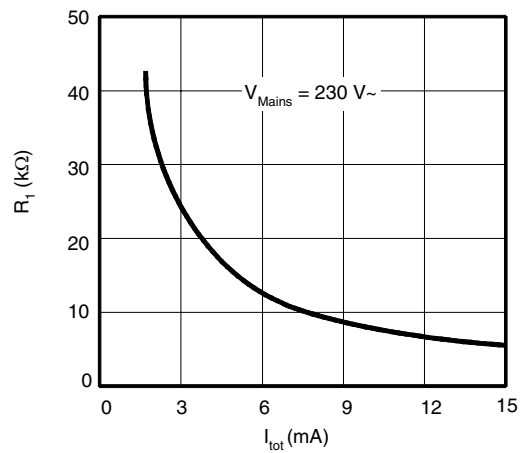
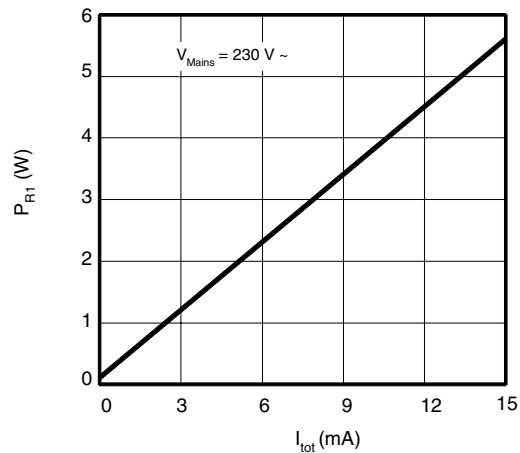


Figure 8. Power Dissipation of R_1 According to Current Consumption



Absolute Maximum Ratings

Stresses beyond those listed under “Absolute Maximum Ratings” may cause permanent damage to the device. This is a stress rating only and functional operation of the device at these or any other conditions beyond those indicated in the operational sections of this specification is not implied. Exposure to absolute maximum rating conditions for extended periods may affect device reliability.

Parameters	Pin	Symbol	Value	Unit
Supply current	5	$-I_S$	30	mA
Synchronous current	8	I_{sync}	5	mA
Output current ramp generator	1	I_O	3	mA
Input voltages	1, 3, 4, 6	$-V_I$	$\leq V_S$	V
	2	$-V_I$	2 to V_S	V
	8	$\pm V_I$	≤ 7.3	V
Power dissipation $T_{amb} = 45^\circ\text{C}$ $T_{amb} = 100^\circ\text{C}$		P_{tot}	400	mW
		P_{tot}	125	mW
Junction temperature		T_j	125	$^\circ\text{C}$
Operating ambient temperature range		T_{amb}	0 to 100	$^\circ\text{C}$
Storage temperature range		T_{stg}	-40 to +125	$^\circ\text{C}$

Thermal Resistance

Parameters	Symbol	Value	Unit
Junction ambient SO8	R_{thJA}	200	K/W
Junction ambient DIP8	R_{thJA}	110	K/W

Electrical Characteristics

$-V_S = 8.8\text{ V}$, $T_{amb} = 25^\circ\text{C}$, reference point pin 7, unless otherwise specified

Parameters	Test Conditions	Pin	Symbol	Min.	Typ.	Max.	Unit
Supply-voltage limitation	$-I_S = 1\text{ mA}$	5	$-V_S$	9.0	9.5	10.0	V
	$-I_S = 10\text{ mA}$		$-V_S$	9.1	9.6	10.1	V
Supply current		5	$-I_S$			500	μA
Voltage limitation	$I_g = \pm 1\text{ mA}$	8	$\pm V_I$	7.7	8.2	8.7	V
Synchronization current		8	$\pm I_{sync}$	0.12			mA
Zero detector		8	$\pm I_{sync}$		35		μA
Output pulse width	$V_M = 230\text{ V} \sim$ $R_{sync} = 220\text{ k}\Omega$ $R_{sync} = 470\text{ k}\Omega$	6	t_P		260		μs
		6	t_P		460		μs
Output pulse current	$V_6 = 0\text{ V}$	6	$-I_O$	100			mA
Comparator							
Input offset voltage		3, 4	$\pm V_{IO}$			15	mV
Input bias current		4	I_{IB}			1	μA
Common-mode input voltage		3, 4	$-V_{IC}$	1		$(V_S - 1)$	V

Electrical Characteristics (Continued)

$-V_S = 8.8\text{ V}$, $T_{\text{amb}} = 25^\circ\text{C}$, reference point pin 7, unless otherwise specified

Parameters	Test Conditions	Pin	Symbol	Min.	Typ.	Max.	Unit
Threshold internal reference	$V_3 = 0\text{ V}$	4	$-V_{\text{Ref}}$		1.4		V
Ramp Generator, Figure 1 on page 2							
Period	$-I_S = 1\text{ mA}$ $I_{\text{sync}} = 1\text{ mA}$ $C_1 = 100\text{ }\mu\text{F}$ $C_2 = 2.2\text{ }\mu\text{F}$ $R_4 = 100\text{ k}\Omega$	1	T		1.5		s
Final voltage		1	$-V_1$	1.2	1.6	2.0	V
Initial voltage		1	$-V_1$	7.2	7.6	8.0	V
Charge current	$V_2 = -V_S$, $I_8 = -1\text{ mA}$	2	$-I_2$	14	20	26	μA

Applications

Figure 9. Power Blinking Switch with $f \approx 2.7\text{ Hz}$, Duty Cycle 1:1, Power Range 0.5 to 2.2 kW

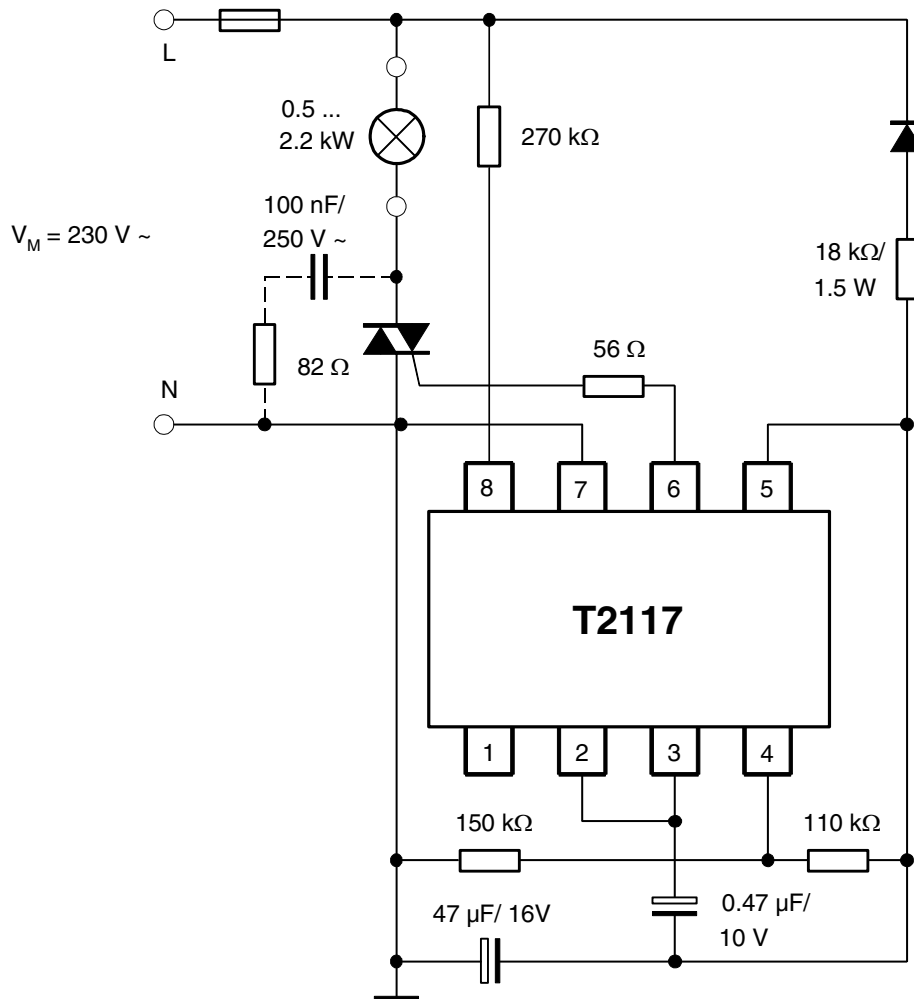


Figure 10. Power Switch

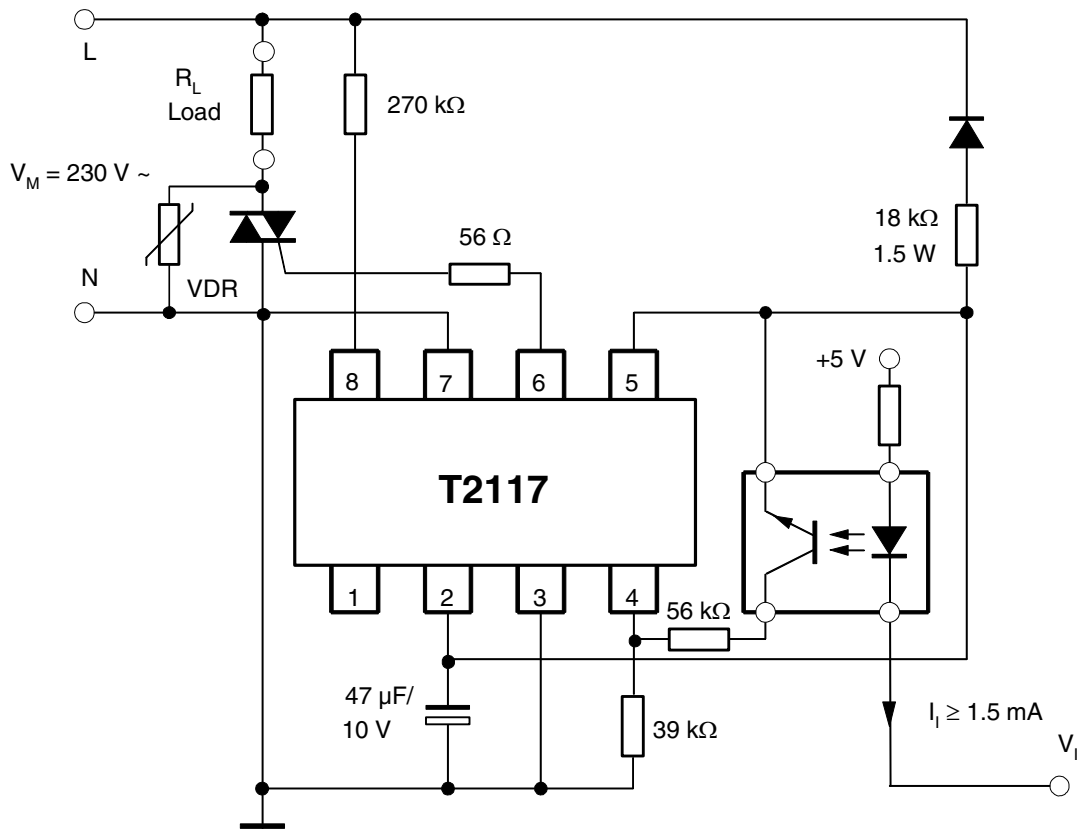
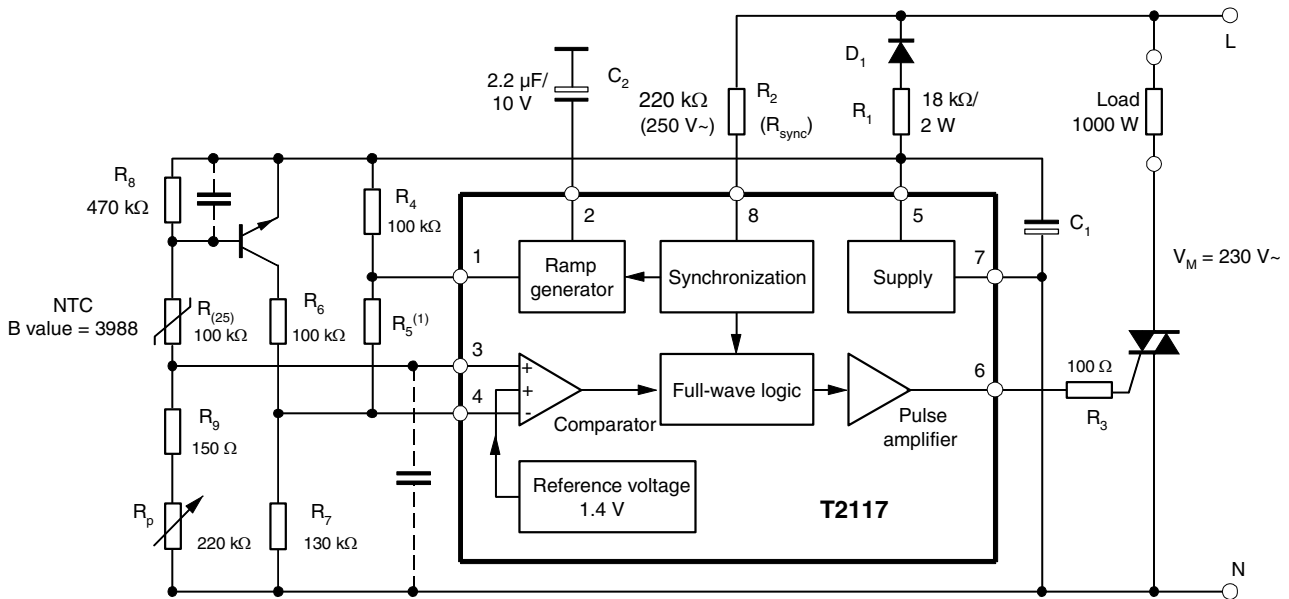


Figure 11. Temperature Control 15°C to 35°C with Sensor Monitoring



$R_{(25)} = 100 \text{ k}\Omega / B = 3988 \rightarrow R_{(15)} = 159 \text{ k}\Omega, R_{(35)} = 64.5 \text{ k}\Omega, R_{5(1)}$ determines the proportional range.

Figure 12. Room Temperature Control with Definite Reduction (Remote Control) for a Temperature Range of 5 to 30°C

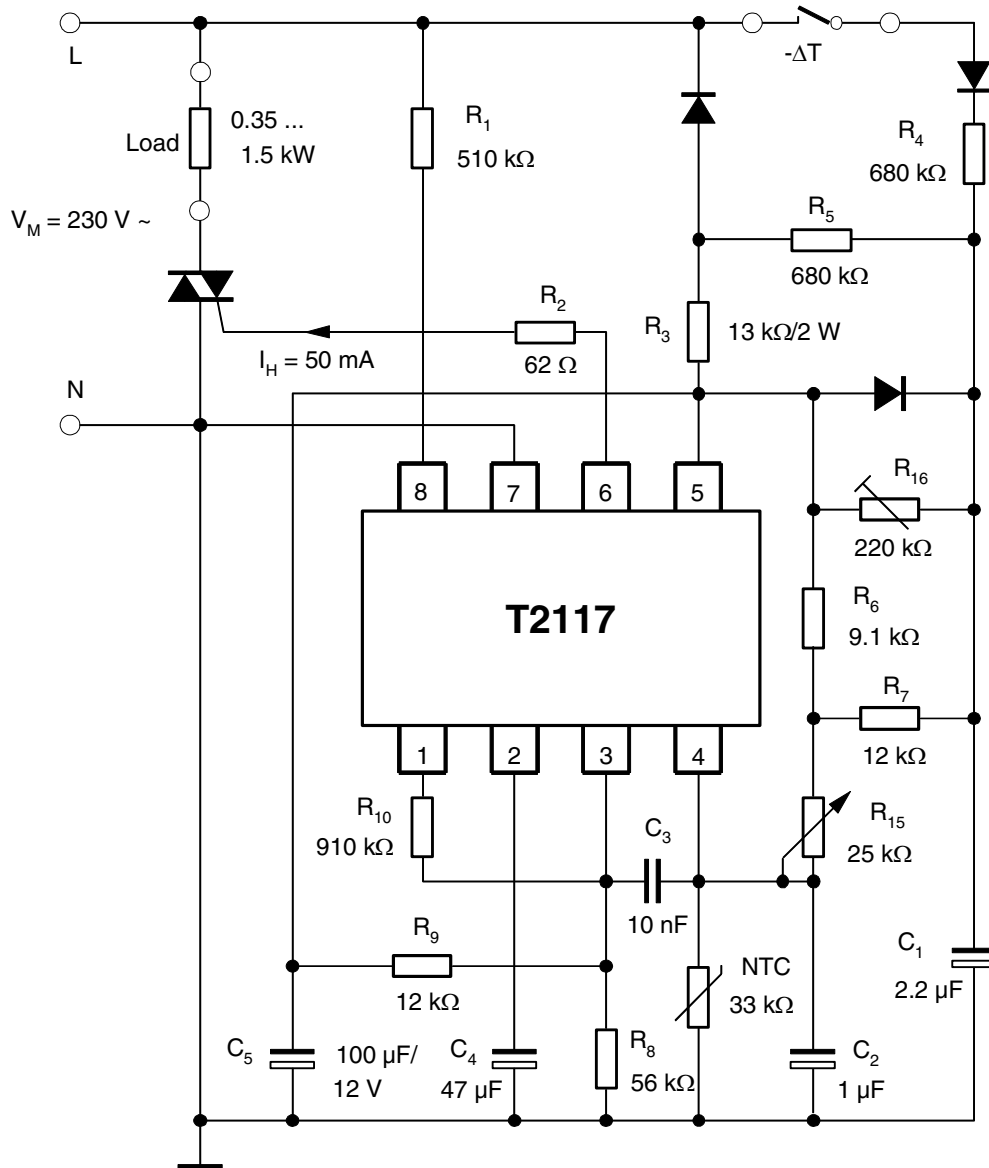


Figure 13. Two-point Temperature Control for a Temperature Range of 15°C to 30°C

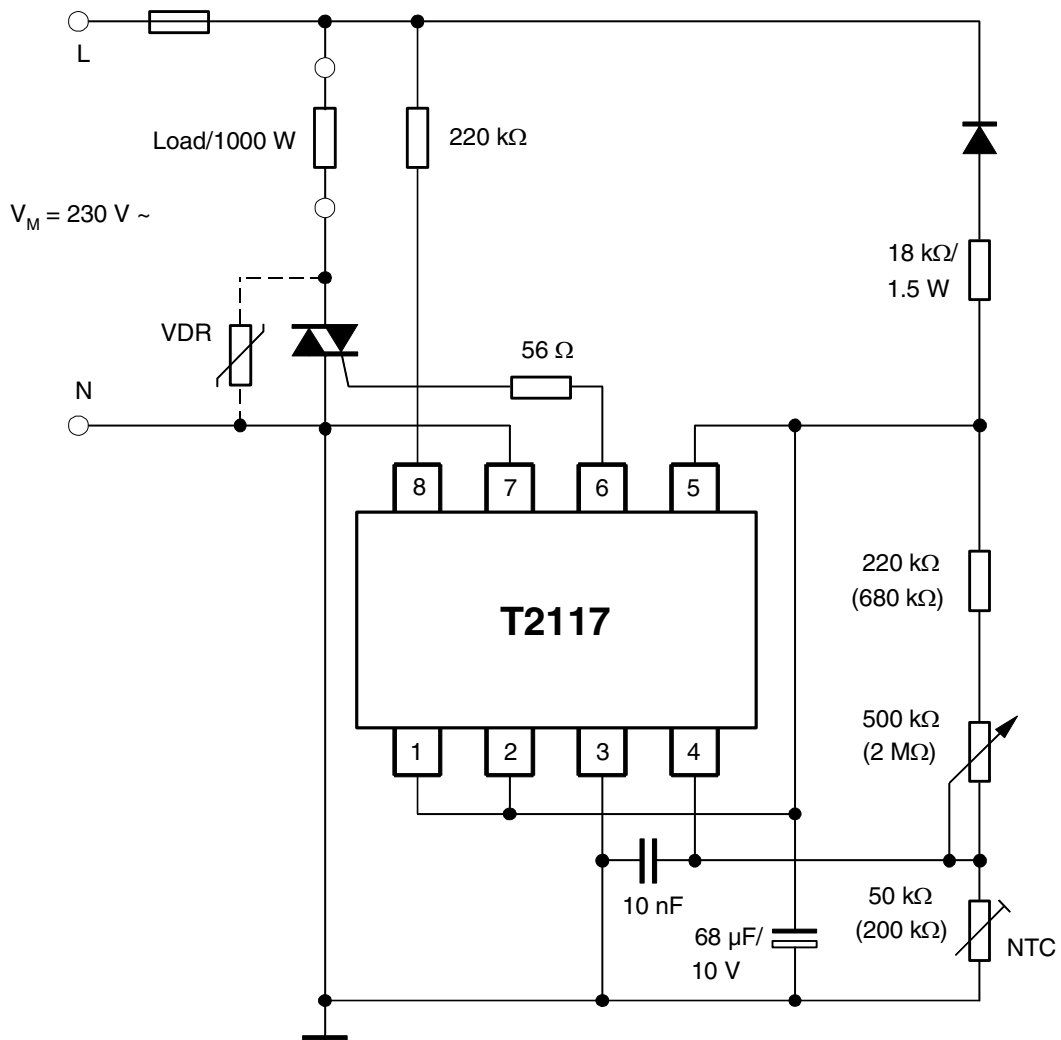
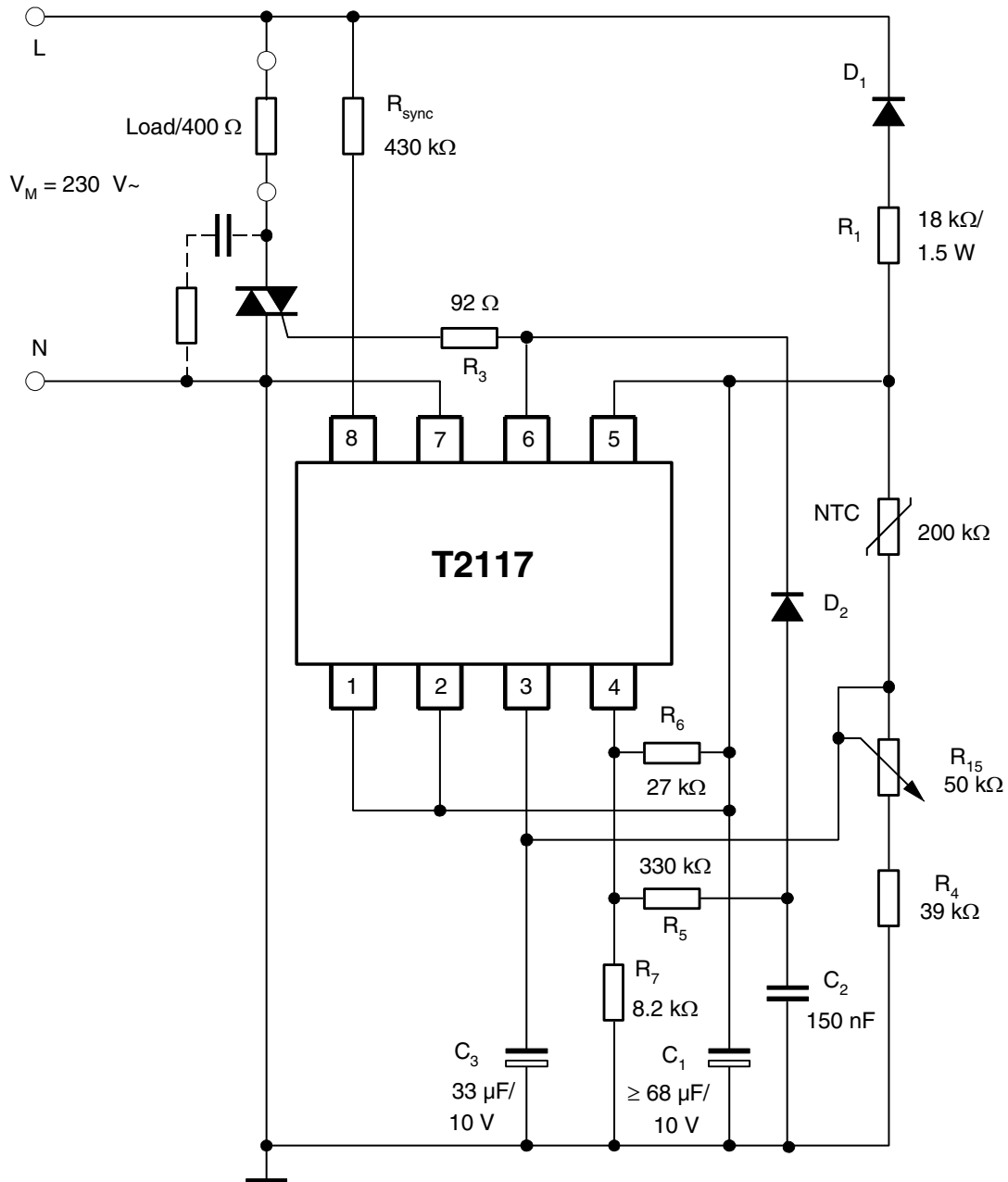


Figure 14. Two-point Temperature Control for a Temperature of 18°C to 32°C and a Hysteresis of $\pm 0.5^\circ\text{C}$ at 25°C



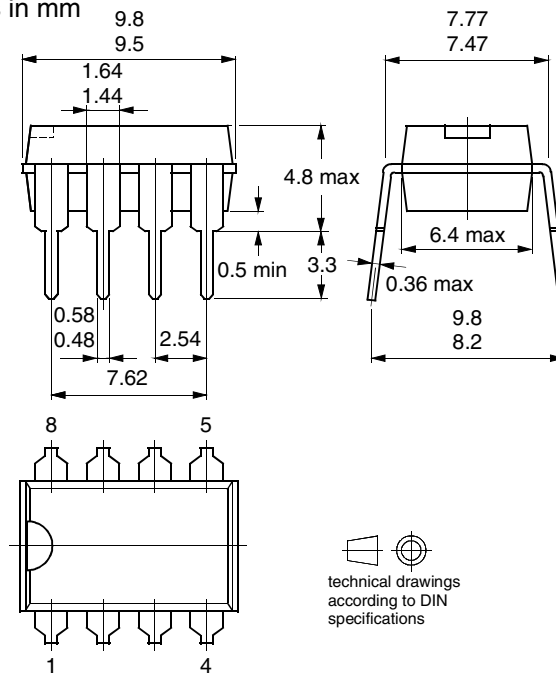
Ordering Information

Extended Type Number	Package	Remarks
T2117-3AS	DIP8	Tube
T2117-TAS	SO8	Tube
T2117-TAQ	SO8	Taped and reeled

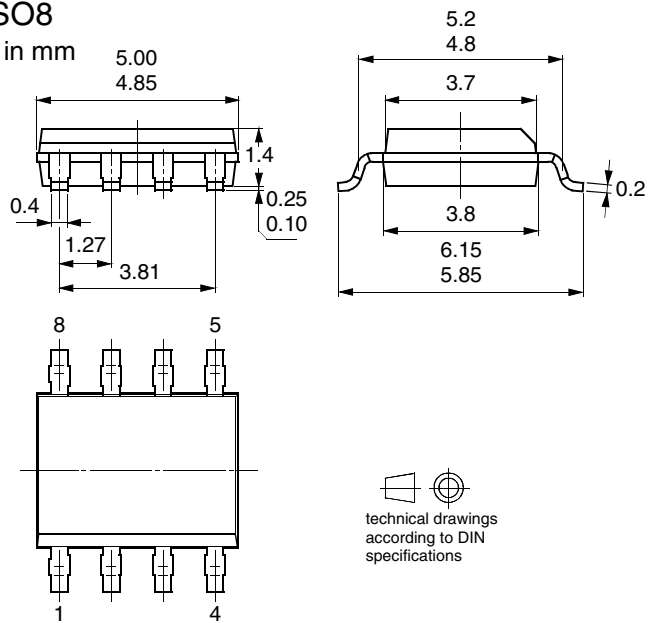
Package Information

Package DIP8

Dimensions in mm



Package SO8
Dimensions in mm





Atmel Corporation

2325 Orchard Parkway
San Jose, CA 95131, USA
Tel: 1(408) 441-0311
Fax: 1(408) 487-2600

Regional Headquarters

Europe

Atmel Sarl
Route des Arsenaux 41
Case Postale 80
CH-1705 Fribourg
Switzerland
Tel: (41) 26-426-5555
Fax: (41) 26-426-5500

Asia

Room 1219
Chinachem Golden Plaza
77 Mody Road Tsimshatsui
East Kowloon
Hong Kong
Tel: (852) 2721-9778
Fax: (852) 2722-1369

Japan

9F, Tonetsu Shinkawa Bldg.
1-24-8 Shinkawa
Chuo-ku, Tokyo 104-0033
Japan
Tel: (81) 3-3523-3551
Fax: (81) 3-3523-7581

Atmel Operations

Memory

2325 Orchard Parkway
San Jose, CA 95131, USA
Tel: 1(408) 441-0311
Fax: 1(408) 436-4314

Microcontrollers

2325 Orchard Parkway
San Jose, CA 95131, USA
Tel: 1(408) 441-0311
Fax: 1(408) 436-4314

La Chantrerie
BP 70602
44306 Nantes Cedex 3, France
Tel: (33) 2-40-18-18-18
Fax: (33) 2-40-18-19-60

ASIC/ASSP/Smart Cards

Zone Industrielle
13106 Rousset Cedex, France
Tel: (33) 4-42-53-60-00
Fax: (33) 4-42-53-60-01

1150 East Cheyenne Mtn. Blvd.
Colorado Springs, CO 80906, USA
Tel: 1(719) 576-3300
Fax: 1(719) 540-1759

Scottish Enterprise Technology Park
Maxwell Building
East Kilbride G75 0QR, Scotland
Tel: (44) 1355-803-000
Fax: (44) 1355-242-743

RF/Automotive

Theresienstrasse 2
Postfach 3535
74025 Heilbronn, Germany
Tel: (49) 71-31-67-0
Fax: (49) 71-31-67-2340

1150 East Cheyenne Mtn. Blvd.
Colorado Springs, CO 80906, USA
Tel: 1(719) 576-3300
Fax: 1(719) 540-1759

Biometrics/Imaging/Hi-Rel MPU/ High Speed Converters/RF Datacom

Avenue de Rochepleine
BP 123
38521 Saint-Egreve Cedex, France
Tel: (33) 4-76-58-30-00
Fax: (33) 4-76-58-34-80

Literature Requests

www.atmel.com/literature

Disclaimer: Atmel Corporation makes no warranty for the use of its products, other than those expressly contained in the Company's standard warranty which is detailed in Atmel's Terms and Conditions located on the Company's web site. The Company assumes no responsibility for any errors which may appear in this document, reserves the right to change devices or specifications detailed herein at any time without notice, and does not make any commitment to update the information contained herein. No licenses to patents or other intellectual property of Atmel are granted by the Company in connection with the sale of Atmel products, expressly or by implication. Atmel's products are not authorized for use as critical components in life support devices or systems.

© Atmel Corporation 2003. All rights reserved.

Atmel® and combinations thereof are the registered trademarks of Atmel Corporation or its subsidiaries.

Other terms and product names may be the trademarks of others.



Printed on recycled paper.