

SPECIFICATIONS



Model Number: CLE2T5
Part Number: 19039202A

Rev: 02
Aug 07, 2018

Mechanical Drawing:

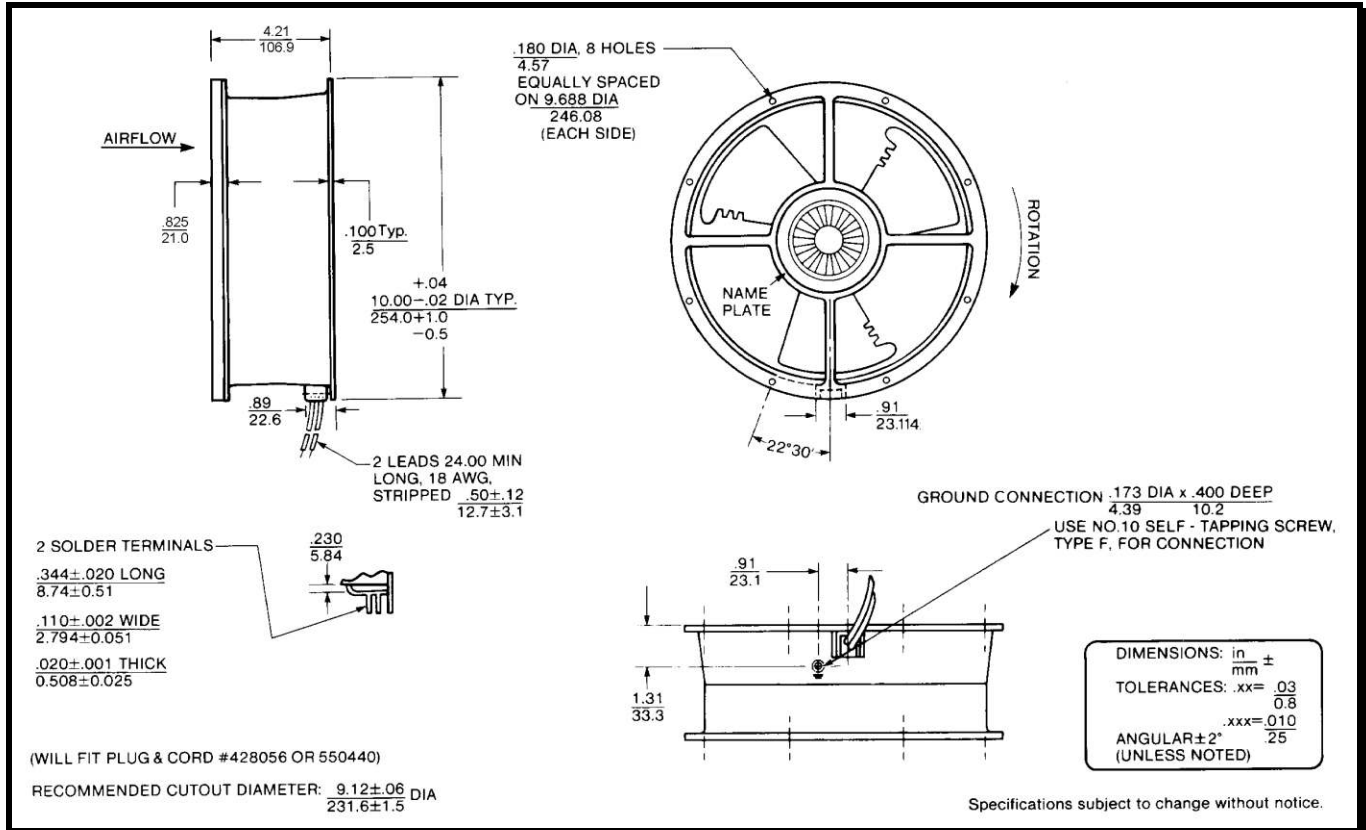

Motor:

Nominal Voltage	= 115 VAC
Frequency	= 50/60 Hz
Nominal Running Current	= 1.11/1.30 amps
Max. Locked Rotor Current	= 2.50 amps
Running Power	= 120/150 watts
Average Speed	= 2650/2800 RPM
Bearings	= Ball
Max. Airflow	= 878/950 CFM
Max. Static Pressure	= 0.55/0.57 in H ₂ O
Acoustic	= 62.1/63.3 dBA

Construction:

Venturi: Aluminum, Black.
 Propeller: Plastic, Black, UL 94V-0

Life Expectancy:

This fan is designed for continuous duty life of 45,000 hours at 60°C.

Additional Features:

Permanent Split Capacitor Motor
 Automatic Reset Thermal Protector
 Automatic Restart Capability
 Operating Temperature: -10°C to 70°C
 Storage Temperature: -40°C to 85°C

Termination:

2 x 0.11" Terminals

Agency Approvals:

UL, CUL, CE

PQ Curve:

