



FODM452, FODM453

5-Pin Mini Flat Package High Speed Transistor Optocoupler

Features

- Compact 5-pin mini flat package
- High speed-1 MBit/s
- Superior CMR-15kV/ μ s at $V_{CM} = 1500V$ (FODM453)
- Performance guaranteed over temperature (0–70°C)
- U.L. recognized (File # E90700)
- VDE0884 recognized (File # 136480)
 - Ordering option V, e.g., FODM452V

Applications

- Line receivers
- Pulse transformer replacement
- Output interface to CMOS-LSTTL-TTL
- Wide bandwidth analog coupling

Description

The FODM452 and FODM453 optocouplers consist of an AlGaAs LED optically coupled to a high speed photo-detector transistor. The devices are housed in a compact 5-pin mini flat package for optimum mounting density. The FODM453 features a high CMR rating for optimum common mode transient immunity.

Package

Schematic

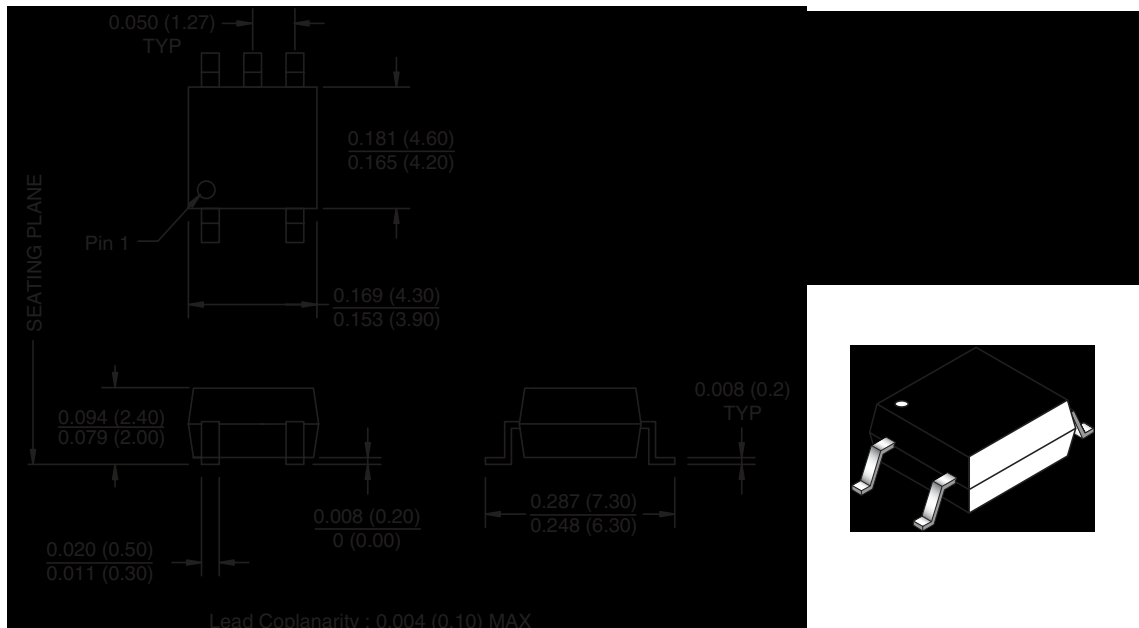

Note:

All dimensions are in inches (millimeters).

Absolute Maximum Ratings ($T_A = 25^\circ\text{C}$ unless otherwise noted)

Stresses exceeding the absolute maximum ratings may damage the device. The device may not function or be operable above the recommended operating conditions and stressing the parts to these levels is not recommended. In addition, extended exposure to stresses above the recommended operating conditions may affect device reliability. The absolute maximum ratings are stress ratings only.

Symbol	Parameter	Value	Units
T_{STG}	Storage Temperature	-40 to +125	$^\circ\text{C}$
T_{OPR}	Operating Temperature	-40 to +85	$^\circ\text{C}$
EMITTER			
I_F (avg)	DC/Average Forward Input Current	25	mA
I_F (pk)	Peak Forward Input Current (50% duty cycle, 1ms P.W.)	50	mA
I_F (trans)	Peak Transient Input Current ($\leq 1\mu\text{s}$ P.W., 300pps)	1.0	A
V_R	Reverse Input Voltage	5	V
P_D	Input Power Dissipation (No derating required over specified operating temp range)	45	mW
DETECTOR			
I_O (avg)	Average Output Current	8	mA
I_O (pk)	Peak Output Current	16	mA
V_{CC}	Supply Voltage	-0.5 to 30	V
V_O	Output Voltage	-0.5 to 20	V
P_D	Output Power Dissipation (No derating required over specified operating temp range)	100	mW

Electrical Characteristics (T_A = 0 to 70°C unless otherwise specified)

Individual Component Characteristics

Symbol	Parameter	Test Conditions	Min.	Typ.*	Max.	Unit
EMITTER						
V _F	Input Forward Voltage	I _F = 16mA, T _A = 25°C		1.60	1.7	V
		I _F = 16mA			1.8	
B _{VR}	Input Reverse Breakdown Voltage	I _R = 10μA	5.0			V
ΔV _F /ΔT _A	Temperature Coefficient of Forward Voltage	I _F = 16mA		-1.8		mV/°C
DETECTOR						
I _{OH}	Logic High Output Current	I _F = 0mA, V _O = V _{CC} = 5.5V, T _A = 25°C		.001	0.5	μA
		I _F = 0 mA, V _O = V _{CC} = 15V, T _A = 25°C		.001	1	
		I _F = 0mA, V _O = V _{CC} = 15V			50	
I _{CCL}	Logic Low Supply Current	I _F = 16mA, V _O = Open, V _{CC} = 15V		100	200	μA
I _{CCH}	Logic high supply current	I _F = 0 mA, V _O = Open, V _{CC} = 15V, T _A = 25°C		0.05	1	μA
		I _F = 0mA, V _O = Open, V _{CC} = 15V			2	

Transfer Characteristics

Symbol	Parameter	Test Conditions	Min.	Typ.*	Max	Unit	
COUPLED							
CTR	Current Transfer Ratio ⁽¹⁾	I _F = 16mA, V _{CC} = 4.5V	T _A = 25°C V _{OL} =0.4V	20		50	%
			V _{OL} =0.5V	15			
V _{OL}	Logic LOW Output Voltage	I _F = 16mA, I _O = 3mA, V _{CC} = 4.5V, T _A = 25°C			0.4	V	
		I _F = 16mA, I _O = 2.4mA, V _{CC} = 4.5 V			0.5		

Switching Characteristics (V_{CC} = 5V)

Symbol	Parameter	Test Conditions	Device	Min.	Typ.*	Max.	Unit
T _{PHL}	Propagation Delay Time to Logic LOW	R _L = 1.9kΩ, I _F = 16mA, T _A = 25°C ⁽²⁾ (Fig. 9)			0.40	0.8	μs
		R _L = 1.9kΩ, I _F = 16mA ⁽²⁾ (Fig. 9)				1.0	
T _{PLH}	Propagation Delay Time to Logic HIGH	R _L = 1.9kΩ, I _F = 16mA, T _A = 25°C ⁽²⁾ (Fig. 9)			0.35	0.8	μs
		R _L = 1.9kΩ, I _F = 16mA ⁽²⁾ (Fig. 9)				1.0	
CM _H	Common Mode Transient Immunity at Logic HIGH	I _F = 0mA, V _{CM} = 10V _{P-P} , R _L = 1.9kΩ, T _A = 25°C ⁽³⁾ (Fig. 10)	FODM452	5	15		KV/μs
		I _F = 0mA, V _{CM} = 1500V _{P-P} , R _L = 1.9kΩ, T _A = 25°C ⁽³⁾ (Fig. 10)	FODM453	15	40		KV/μs
CM _L	Common Mode Transient Immunity at Logic LOW	I _F = 16mA, V _{CM} = 10V _{P-P} , R _L = 1.9kΩ, T _A = 25°C ⁽³⁾ (Fig. 10)	FODM452	5	15		KV/μs
		I _F = 16mA, V _{CM} = 1500V _{P-P} , R _L = 1.9kΩ, T _A = 25°C ⁽³⁾ (Fig. 10)	FODM453	15	40		KV/μs
BW	Bandwidth	R _L = 100Ω			3		MHz

Isolation Characteristics

Symbol	Characteristics	Test Conditions	Min.	Typ.*	Max.	Unit
V _{ISO}	Withstand Insulation Test Voltage	RH ≤ 50%, T _A = 25°C, t = 1 min. ⁽⁴⁾	3750			V _{RMS}
C _{I-O}	Capacitance (Input to Output)	f = 1MHz ⁽⁴⁾		0.2		pF

*All Typicals at T_A = 25°C

Notes:

1. Current Transfer Ratio is defined as a ratio of output collector current, I_O , to the forward LED input current, I_F , times 100%.
2. The 1.9k Ω load represents 1 TTL unit load of 1.6mA and 5.6k Ω pull-up resistor.
3. Common mode transient immunity in logic high level is the maximum tolerable (positive) dV_{cm}/dt on the leading edge of the common mode pulse signal V_{CM} , to assure that the output will remain in a logic high state (i.e., $V_O > 2.0V$). Common mode transient immunity in logic low level is the maximum tolerable (negative) dV_{cm}/dt on the trailing edge of the common mode pulse signal, V_{CM} , to assure that the output will remain in a logic low state (i.e., $V_O < 0.8V$).
4. Device is considered a two terminal device: Pins 1, and 3 are shorted together and Pins 4, 5, and 6 are shorted together.

Typical Performance Curves

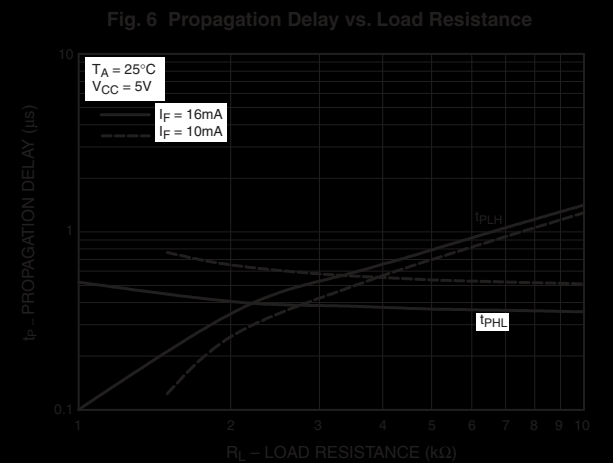
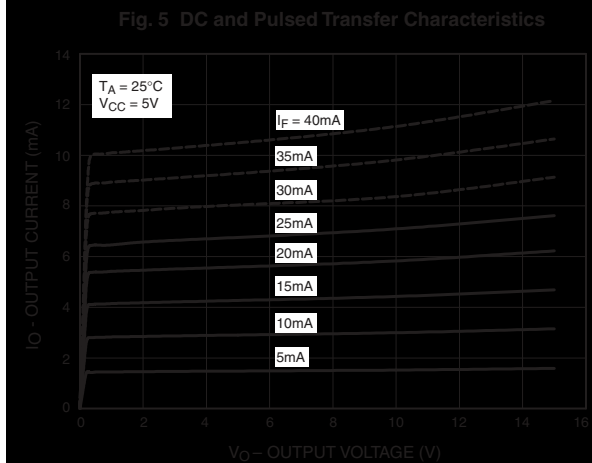
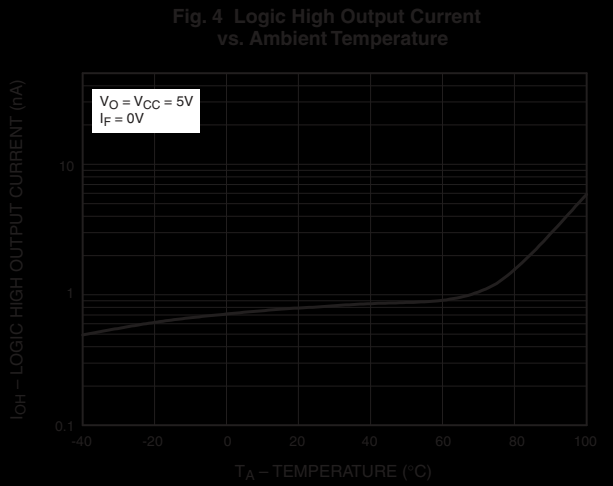
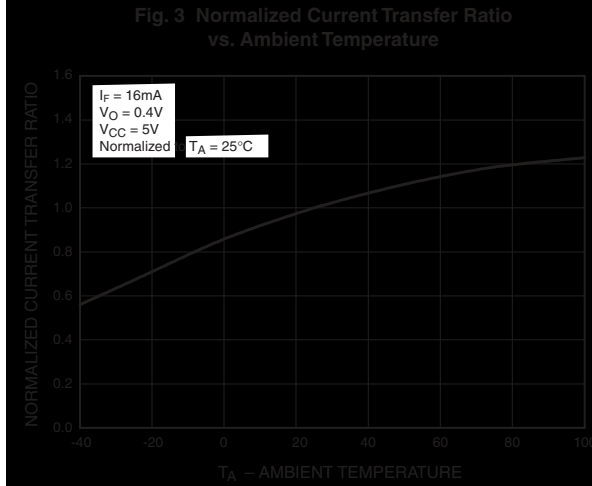
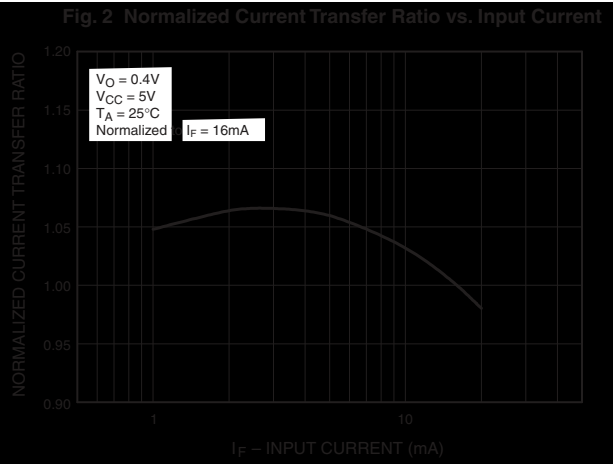
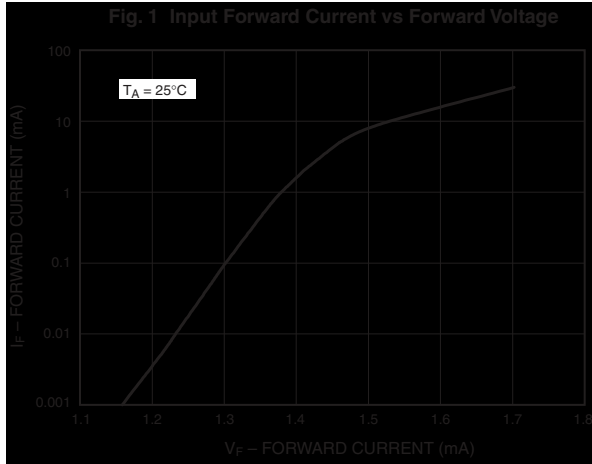

Typical Performance Curves (Continued)

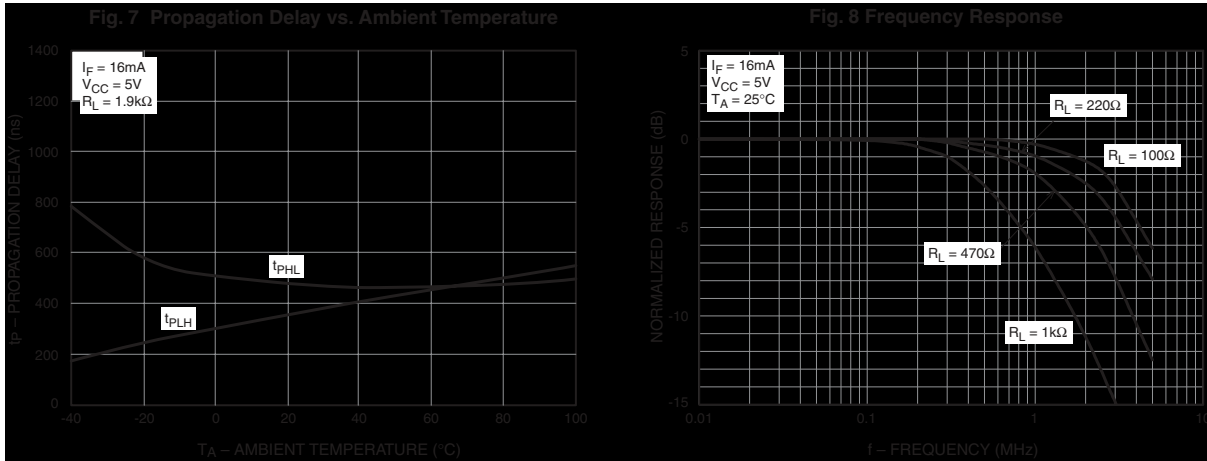

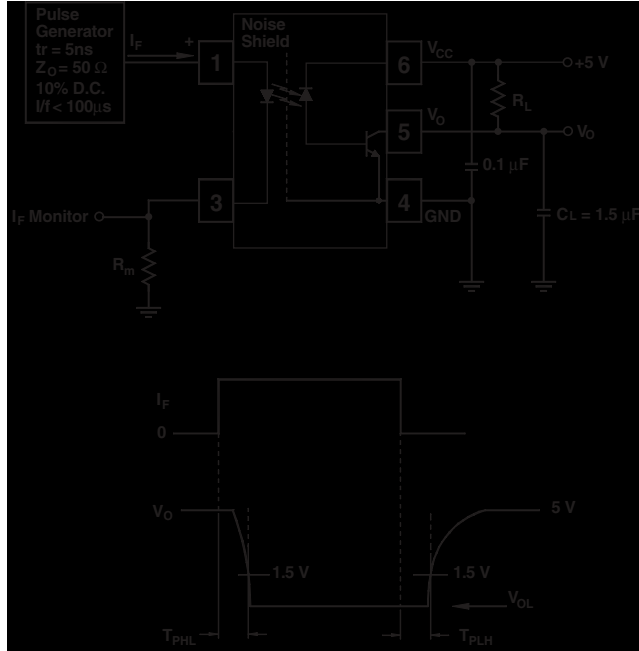

Fig. 9 Switching Time Test Circuit

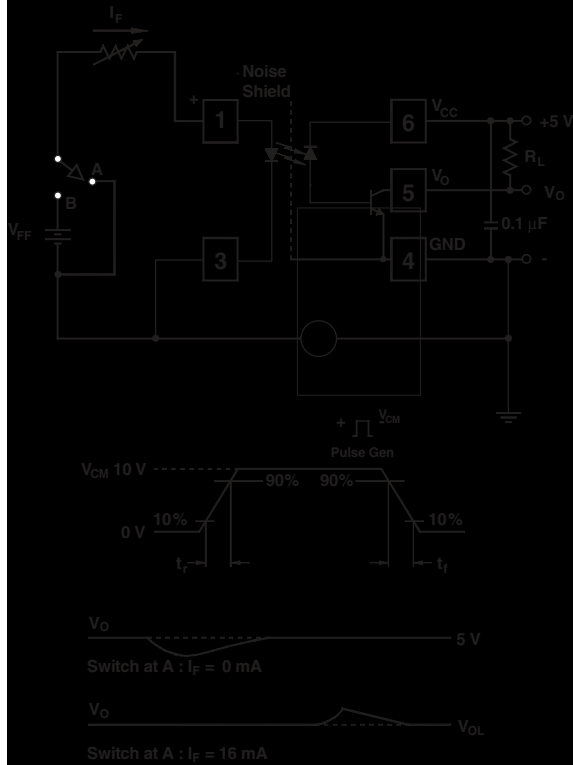
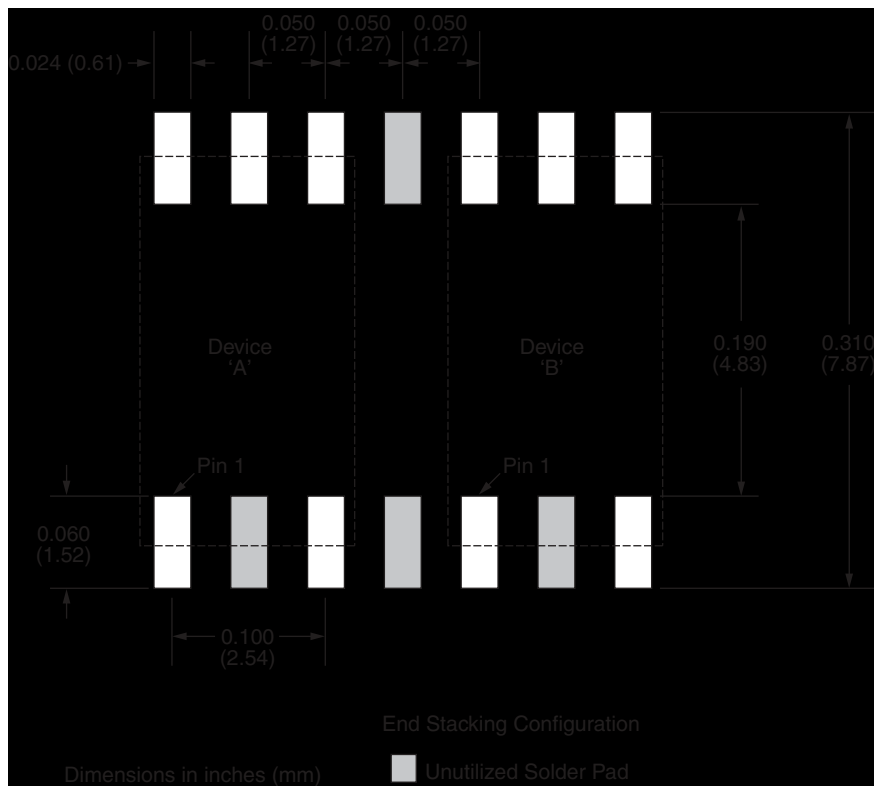

Fig. 10 Common Mode Immunity Test Circuit

Footprint Drawing for PCB Layout



Ordering Information

Option	Order Entry Identifier (example)	Description
R1	FODM452R1	Tape and Reel (500 per reel)
R2	FODM452R2	Tape and Reel (2500 per reel)
V	FODM452V	VDE0884
R1V	FODM452R1V	VDE0884, Tape and Reel (500 per reel)
R2V	FODM452R2V	VDE0884, Tape and Reel (2500 per reel)

Marking Information

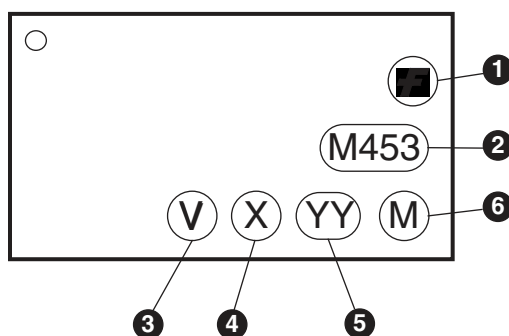

Definitions	
1	Fairchild logo
2	Device number
3	VDE mark (Note: Only appears on parts ordered with VDE option – See order entry table)
4	One digit year code, e.g., '7'
5	Two digit work week ranging from '01' to '53'
6	Assembly package code

Carrier Tape Specifications



Note:

All dimensions are in millimeters.

Reflow Profile

