

DM3730 / AM3703 Torpedo™ + Wireless SOM System on Module

WiLink™ 7.0 wireless solution on a single board that is less than one square inch

Combine a powerful applications processor with PC-like speeds and a wireless chipset with 802.11a/b/g/n, Bluetooth 4.0/BLE, and GPS support; toss in Android™ and Linux™ BSPs developed using processes compliant with the ISO 13485 medical system standard; and the outcome is an innovative off-the-shelf solution that reduces your development time and risk.

The award-winning Torpedo + Wireless System on Module (SOM) is an ultra-compact form factor built around the Texas Instruments (TI) DaVinci™ DM3730 processor or Sitara™ AM3703 processor and WiLink™ 7.0 wireless solution. Confining these two systems to a single board isolates the complex design, manufacturing, and wireless certifications from the rest of your product.

The DM3730/AM3703 Torpedo + Wireless SOM occupies less than one square inch, but boasts PC-like speeds up to 1 GHz with long battery life. Partnered with such high performance is a startlingly low power consumption in suspend state. This balance of speed and power is accomplished through Logic PD's vast system design experience; understanding the most detailed workings of each component and their interaction with one another creates a product that operates at optimal efficiency.



DM3730 / AM3703 Torpedo™ + Wireless SOM

The WL1283 wireless chipset provides access to all the wireless protocols required in today's connected world. 802.11a/b/g/n, Bluetooth, and GPS signals are natively integrated with this SOM and with Logic PD BSPs.

By using the same connectors as Logic PD's existing OMAP35x and DM3730/AM3703 Torpedo SOMs, the DM3730/AM3703 Torpedo + Wireless SOM extends the roadmaps of existing products and provides an upgrade path from today's products to future technologies.

The ultra-compact DM3730/AM3703 Torpedo + Wireless SOM is an ideal off-the-shelf solution for applications in markets where wireless connectivity is required and space is a premium. From point-of-care medical products to handheld communication devices, the DM3730/AM3703 Torpedo + Wireless SOM allows for the powerful versatility and compact designs needed in today's market-changing products.

AWARDS WON IN 2012:

- +CONNECT Most Innovative Product
- +*Design News* Golden Mousetrap Award
- +*Embedded Computing Design* Top Embedded Innovation

DM3730 / AM3703 TORPEDO + WIRELESS SOM :: HIGHLIGHTS:

- +Product-ready System on Module with a TI DM3730 or AM3703 ARM® Cortex™-A8 processor running up to 1 GHz
- +Android™ & Linux™ Board Support Packages (BSPs)
- +Wireless connectivity: 802.11a/b/g/n, Bluetooth 4.0/BLE, & GPS
- +FCC & IC modular certified
- +Industrial, commercial, & extended temp configurations
- +Ultra-compact form factor (15 x 33 x 3.8 mm installed)
- +Same connectors as DM3730 / AM3703 Torpedo SOM
- +Long product lifecycle

ZOOM™ DM3730 TORPEDO DEVELOPMENT KIT :: FEATURES:

- +Application baseboard
- +DM3730 Torpedo + Wireless SOM DM3730 Torpedo SOM
- +4.3" WQVGA LCD with 4-wire touchscreen
- +Wattson™ power measurement application
- +Necessary accessories to immediately get up and running

DM3730 / AM3703 Torpedo™ + Wireless SOM Block Diagram

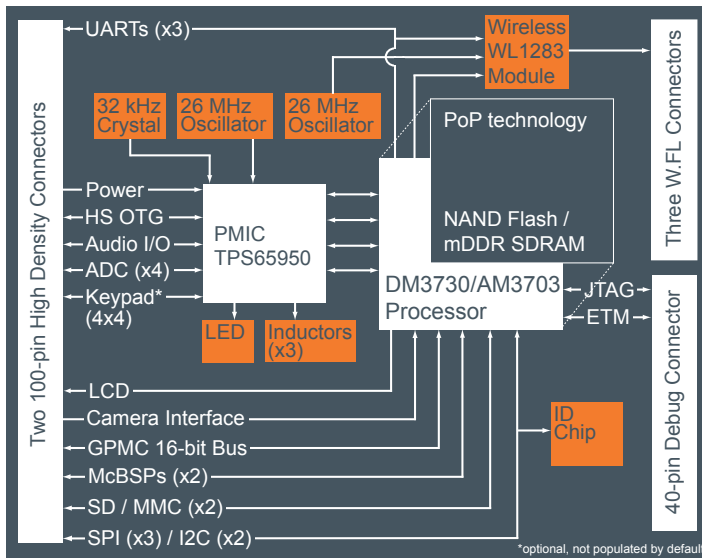

(Block diagram is not drawn to scale; for reference purposes only.)

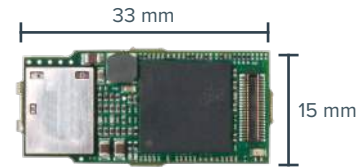

TOP VIEW :: ACTUAL SIZE



BOTTOM VIEW :: ACTUAL SIZE

DM3730 / AM3703 Torpedo + Wireless SOM Ordering Information

Model Number ¹	Speed (MHz)	SDRAM (MB)	NAND Flash (MB)	Temp. (°C)
SOMAM3703-32-1780AKIR	800	256	512	-40°–85° ²
SOMDM3730-32-2780AKCR	1000	256	512	0°–70° ³

NOTES: 1. Custom configurations are available by special order. Please contact Logic PD Sales for details.

2. Junction temperature of the DM3730/AM3703 processor must stay below 105°C.

3. Junction temperature of the DM3730/AM3703 processor must stay below 90°C.

Zoom™ DM3730 Torpedo Development Kit Ordering Information

Model Number	SOM Configuration	Suggested Resale
SDK-DM3730-30-256512R	SOMDM3730-32-2780AKCR SOMDM3730-20-2780AGCR	\$997



6201 Bury Dr. | Eden Prairie, MN 55346

T : 952.941.8071 F : 952.941.8065 | www.logicpd.com

© 2018 Logic PD, Inc. All rights reserved. PN: 1020571 Rev O

LOGIC PD WEBSITE :: DESIGN RESOURCES:

+ Logic PD Products : www.logicpd.com/products

+ Logic PD Technical Support : support@logicpd.com

+ Logic PD Sales : www.logicpd.com/contact/

Product Features

Processor

+ TI DaVinci™ DM3730 or Sitara™ AM3703

ARM® Cortex™-A8 core running up to 1 GHz

+ TMS320C64x DSP core running up to 800 MHz (DM3730 only)

+ POWER SGX™ graphics accelerator (DM3730 only)

Memory

+ Mobile DDR / NAND flash (PoP technology)

256 MB / 512 MB

Wireless Connectivity

+ WL1283 wireless module featuring 802.11a/b/g/n, Bluetooth 4.0/BLE, & GPS

Display

+ Programmable color LCD controller supports up to 24 bpp TFT interface

+ Hardware supports XGA 1024x768 at 24-bit color

Camera

+ Parallel camera interface

Audio

+ I2S-compliant audio codec (16-bit stereo DAC, 13-bit ADC)

User Interface

+ Optional 4x4 keypad interface

PC Card Expansion

+ Multiple SD/MMC card support

USB

+ One USB 2.0 high-speed On-the-Go interface

Serial I/O

+ UARTs, SPI, I2C, McBSPs

GPIO

+ Programmable I/O depending on peripheral requirements

+ General purpose memory controller (GPMC) interface

Debug

+ 40-pin debug connector on top side of SOM

+ JTAG & ETM support

Software

+ Android™ BSP

+ Linux™ BSP

+ LogicLoader™ (bootloader/monitor)

+ Wattson™ power measurement application

Mechanical (Installed)

+ 15 mm wide x 33 mm long x 3.8 mm high

FCC & IC Modular Certified

RoHS Compliant