

LOC		DIST		REVISIONS			
P	LTR	DESCRIPTION	DATE	DNW	APVD		
M		REV PER ECO-09-013326	6-15-09	CT	RL		

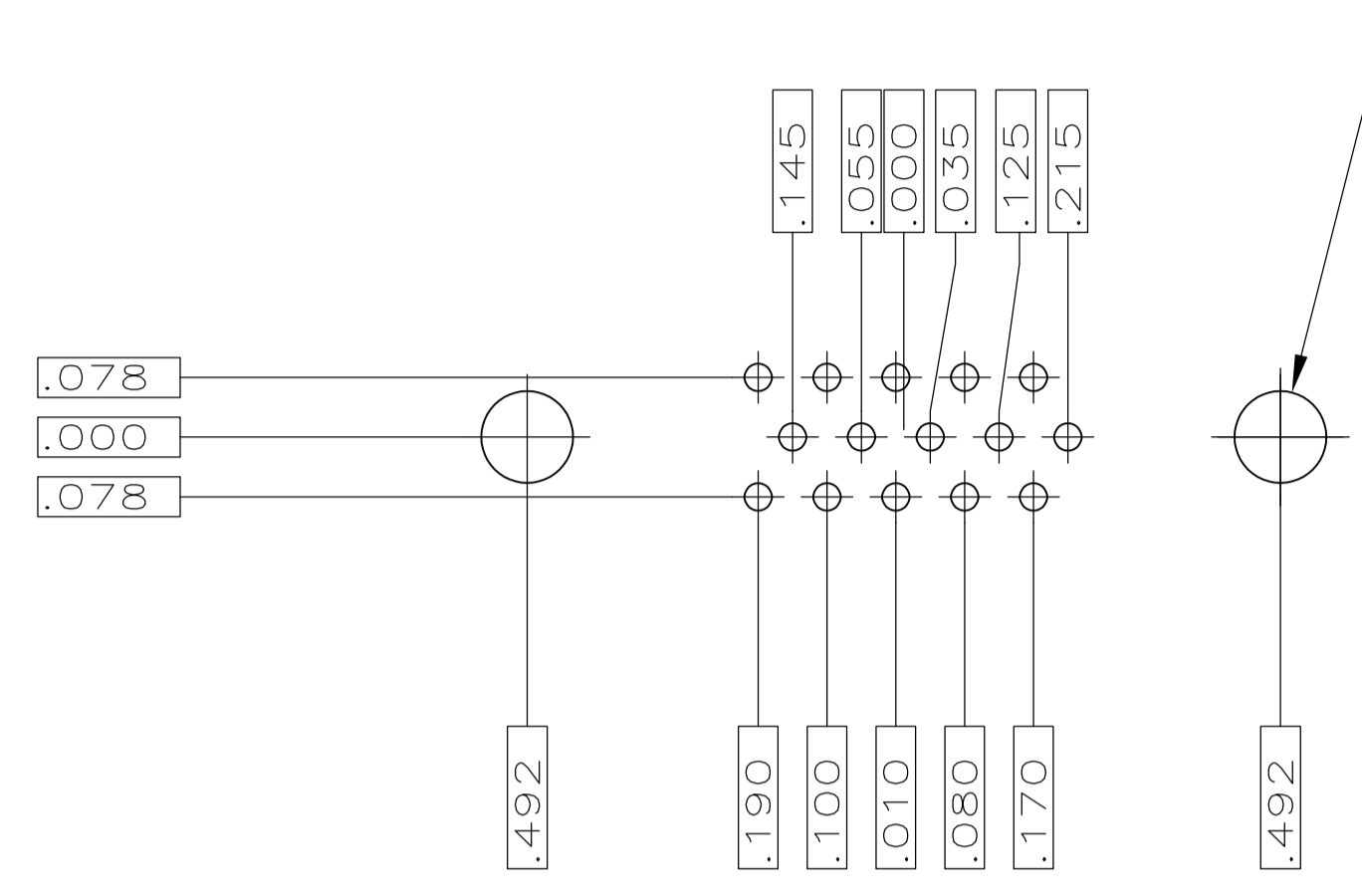

- △ SOCKET CONTACT
CONTACT BODY MAT'L: LEADED NICKEL COPPER (PROPRIETARY)
ALTERNATE MAT'L: COPPER ALLOY PER ASTM-B-197
FINISH: GOLD PER MIL-G-45204 OVER
NICKEL PER QQ-N-290
- △ 2 FINISH: CADMIUM PER QQ-P-416
- △ 3 FINISH: TIN PLATED PER MIL-T-10727
- 4. .040 DIA HOLE IS RECOMMENDED FOR P.C. BOARD
- 5. CONNECTOR MATES WITH ANY TE 15 POSN PLUG
- 6. REPLACEMENT SOCKET TE# 207684-4
- △ 1 UL/CSA DESIGNATION STAMPED IN THIS AREA.
- △ 8 FINISH: ZINC PLATED PER ASTM-B-633, .000200-.000400 THK WITH SUPPLEMENTARY CHROMATE (Cr3+)

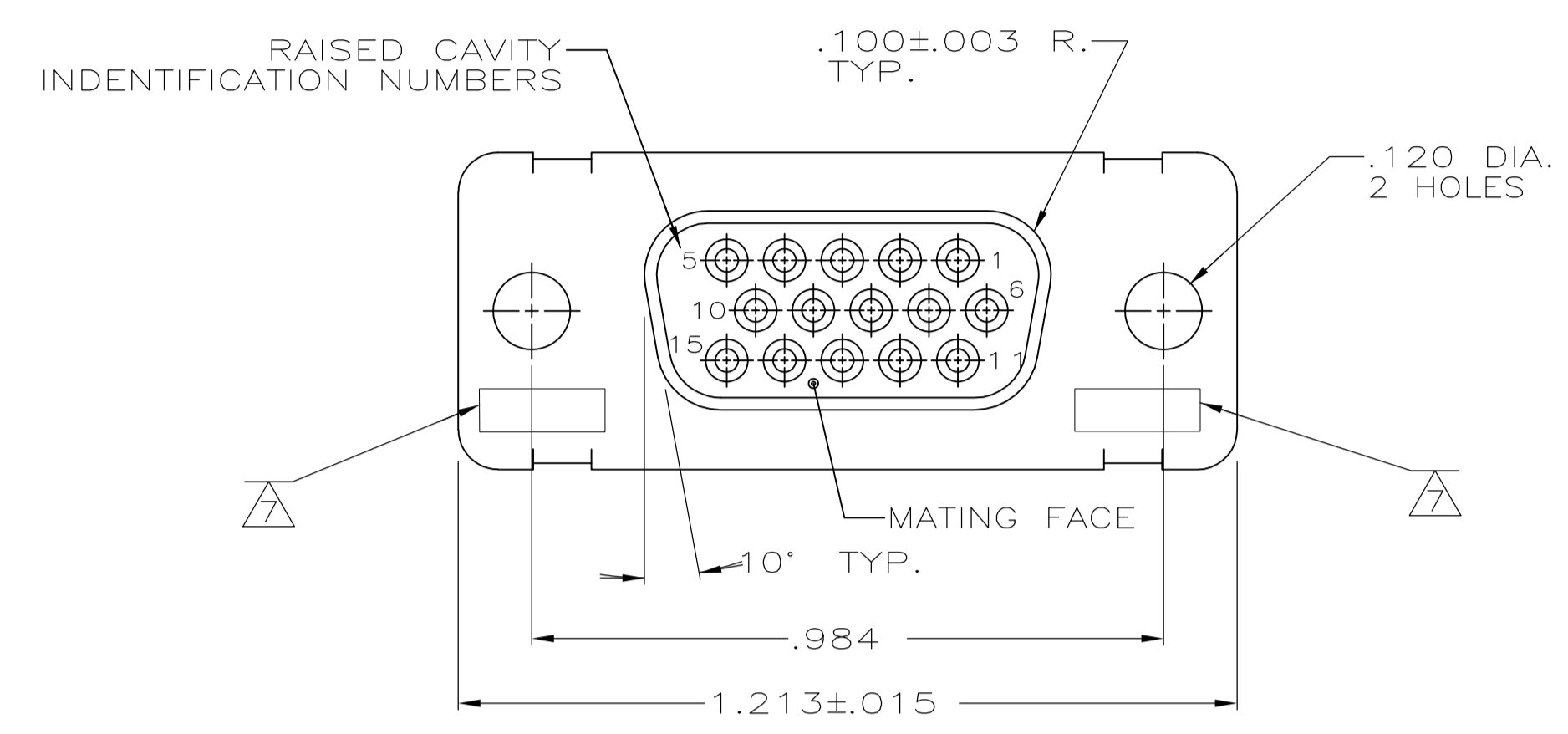
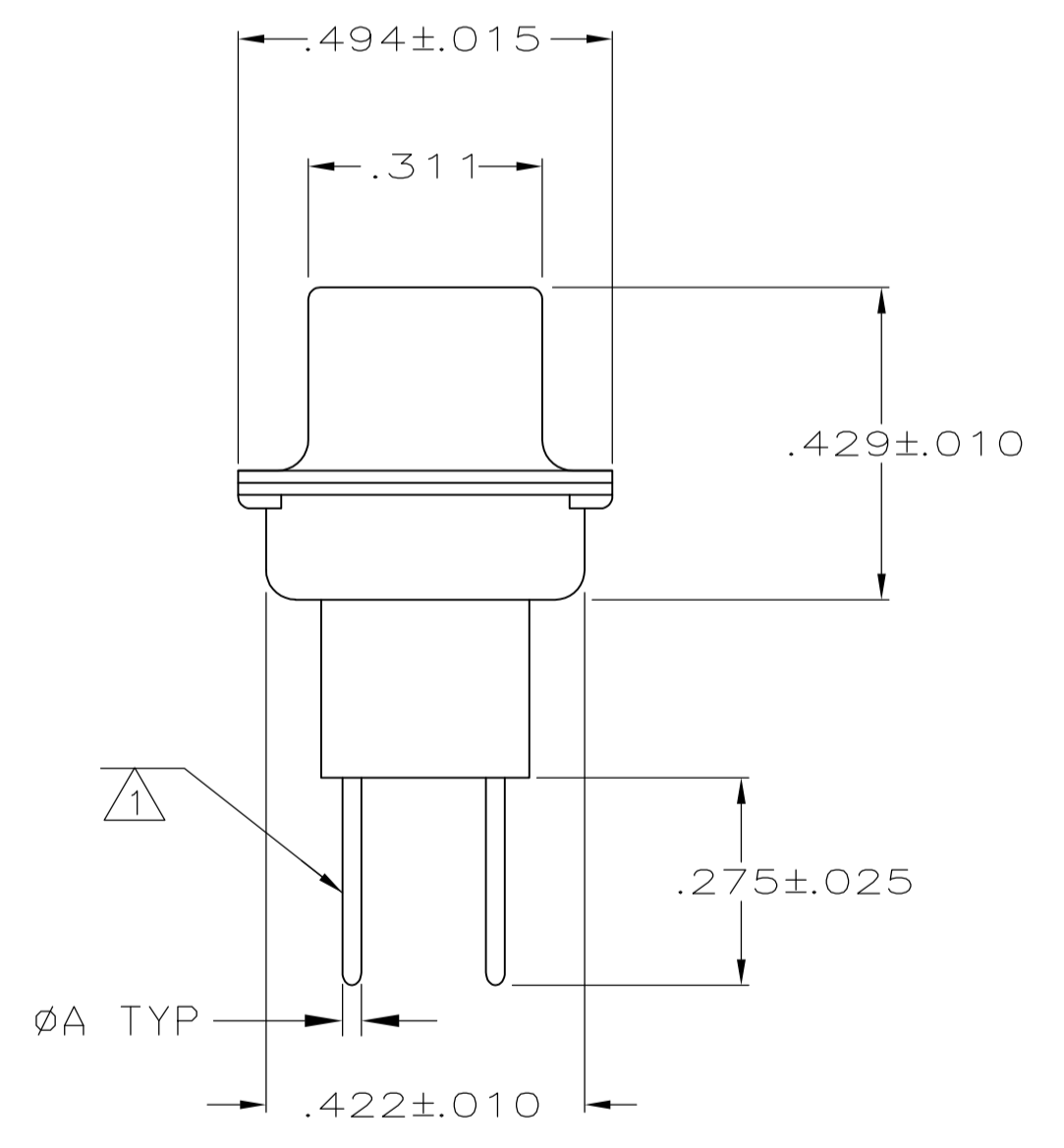
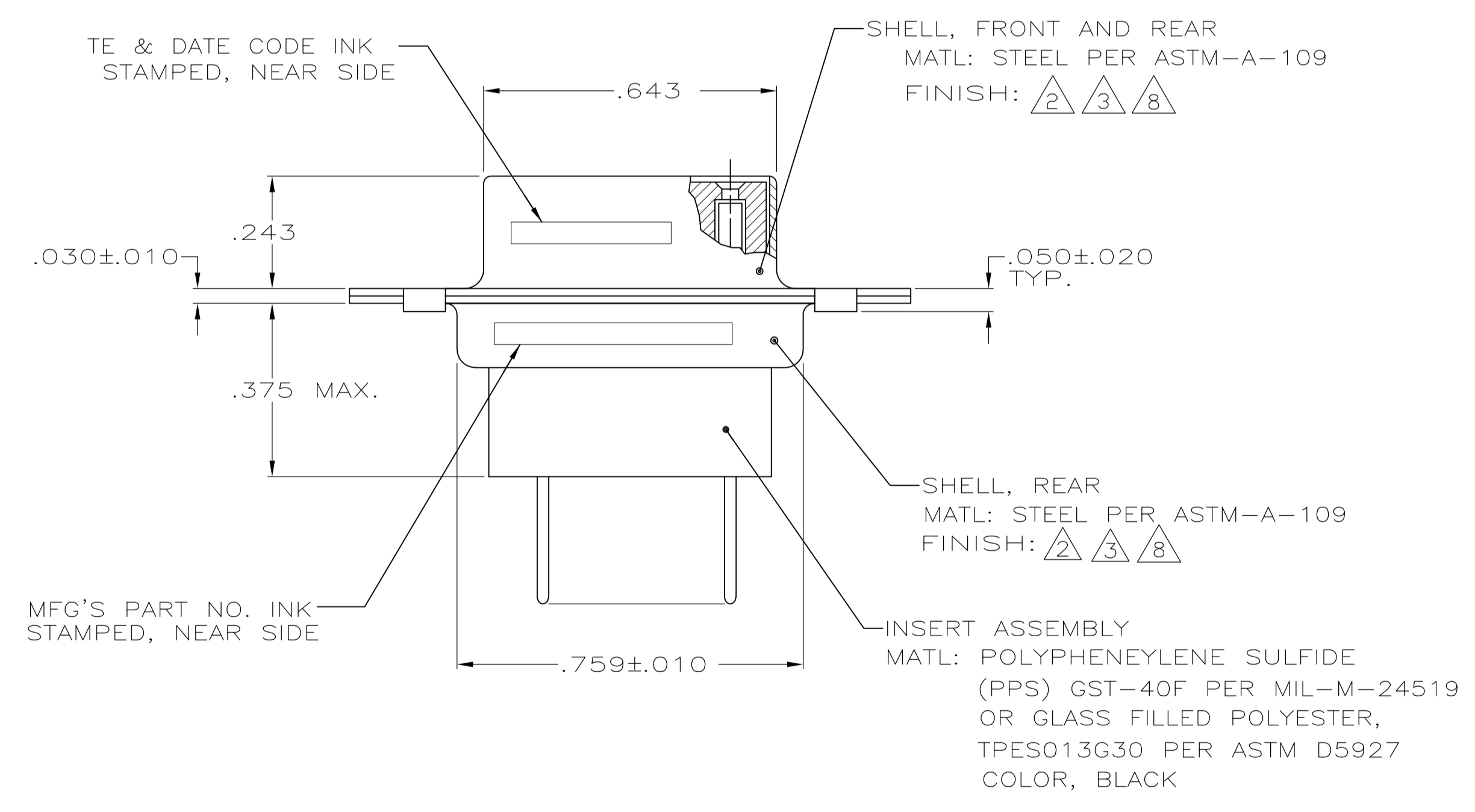

PRELIMINARY- NOT RELEASED FOR PRODUCTION

DIM A	DESCRIPTION	PART NO.
.025	PLATED PER △ 8	5-208872-1
.018	PLATED PER △ 2	208872-3
.025	PLATED PER △ 3	208872-2
.025	PLATED PER △ 2	208872-1

THIS DRAWING IS A CONTROLLED DOCUMENT.

DIMENSIONS: INCHES	TOLERANCES UNLESS OTHERWISE SPECIFIED:	DIN C.C.THOMAS 1-6-88	Tyco Electronics Corporation Harrisburg, PA 17105-3608
0 PLC ± -	1 PLC ± -	1-25-88	
2 PLC ± -	3 PLC ± .005	1-25-88	NAME: F. BALLEW III
4 PLC ± -	ANGLES ± -		PRODUCT SPEC: AMPLIMITE 15 POSN. RCPT. ASSY., W/ LOADED POSTED CONTACTS SIZE 1, SERIES 90
MATERIAL: SEE CALLOUTS	FINISH: SEE CALLOUTS	WEIGHT: -	SIZE: A1
			SCALE: 4:1
			SHEET: 1 OF 1
			REV: M

CUSTOMER DRAWING