

F

E

D

C

B

A

F

E

D

C

B

A

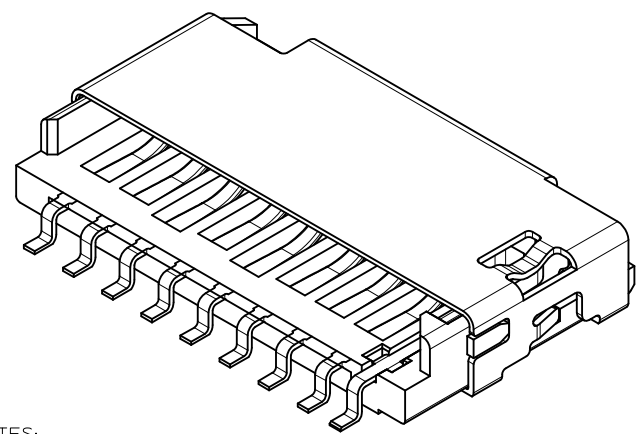
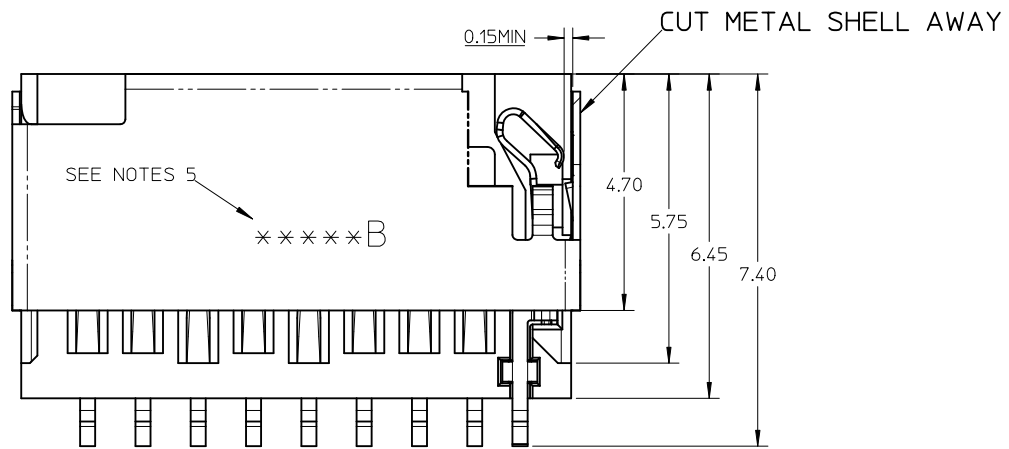

- NOTES:
- MATERIAL:
    - 1-1 HOUSING: HIGH TEMPERATURE THERMOPLASTIC, UL 94V-0, BLACK
    - 1-2 SIGNAL TERMINAL AND DETECT TERMINAL: PHOSPHOR BRONZE
    - 1-3 METAL SHELL: STAINLESS STEEL
  - FINISH:
    - 2-1 SIGNAL TERMINAL: 1.25 MICRON NICKEL MIN UNDER-PLATED, CONTACT AREA SEE TABLE, GOLD FLASH ON SOLDER AREA.
    - 2-2 METAL SHELL: GOLD FLASH PLATED AT SOLDER PAD AREA.
    - 2-3 DETECT PIN: 1.25 MICRON NICKEL MIN UNDER-PLATED, 0.38 MICRON MIN GOLD PLATING ON CONTACT AREA, GOLD FLASH ON SOLDER AREA.
  - PRODUCT SPECIFICATION: PS-105078-001.
  - PACKAGE SPECIFICATION: PK-105078-001.
  - THE MARK SHOULD FOLLOW MOTOROLA'S SPEC."\*\*\*\*\*B"  
 THE FIRST "\*" MEANS THE MANUFACTURE YEAR, THE FOLLOW "\*\*\*\*" MEANS THE MANUFACTUR DAY. FOR EXAMPLE "2008/01/02" SHOULD BE "8002".  
 THE LAST "\*" IS SHIFT IDENTIFY CODE\*A, B, C".  
 THE LAST LETTER "B" IS CUSTOMER VERSION.
  - PRODUCT COMPLIANT TO RoHS DIRECTIVE 2002/95/EC AND ELV 2000/53/EC.

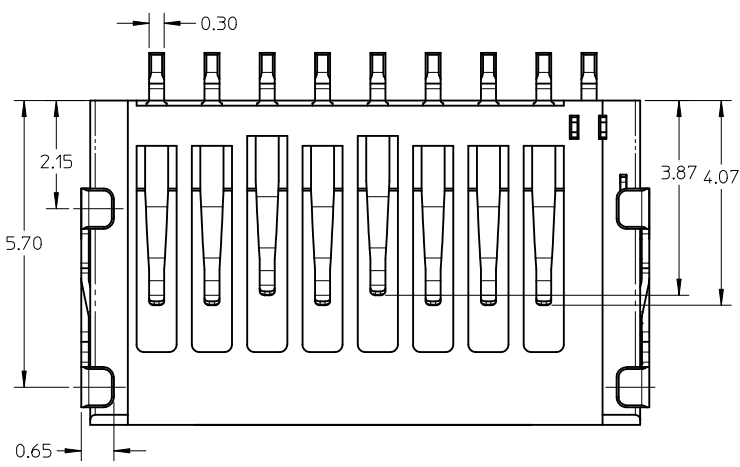
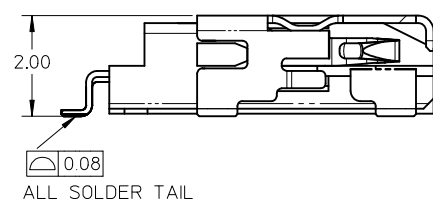
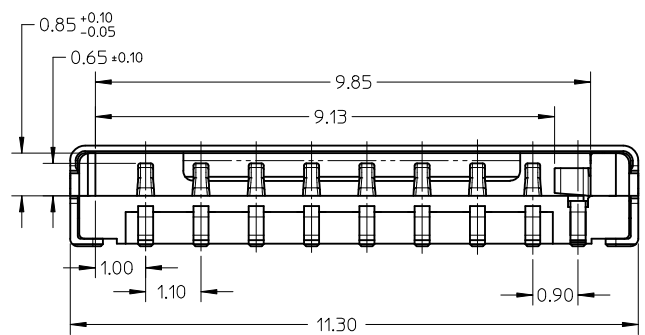

105078-0101	0.38 MICRON MIN. GOLD PLATING
105078-0001	0.76 MICRON MIN. GOLD PLATING
105078-1001	0.1 MICRON MIN. GOLD PLATING
P/N	CONTACT AREA PLATING

ADD PART NUMBER EC NO: SH2012-0261 DRWG:LLI CHKD: APPR:AYIN REV	DESCRIPTION 2012/02/10 2012/02/23	QUALITY SYMBOLS $\nabla_A = 0$ $\nabla_C = 0$ $\nabla_B = 0$	GENERAL TOLERANCES (UNLESS SPECIFIED) mm INCH 4 PLACES ± --- ± --- 3 PLACES ± --- ± --- 2 PLACES ± 0.15 ± --- 1 PLACE ± 0.20 ± --- ANGULAR ± 2 °	DIMENSION STYLE MM ONLY DRAWN BY: LIU LEI DATE: 2008/8/10 CHECKED BY: WFDENG DATE: 2008/8/10 APPROVED BY: WFDENG DATE: 2010/02/11 MATERIAL NO.	SCALE 1:1 TITLE 2.0H TFR HEADER WITH SIDE DETECT PIN	DESIGN UNITS METRIC THIRD ANGLE PROJECTION
	DRAFT WHERE APPLICABLE MUST REMAIN WITHIN DIMENSIONS			SEE TABLE	MOLEX INCORPORATED SD-105078-001	SHEET NO. 1 OF 2
	THIS DRAWING CONTAINS INFORMATION THAT IS PROPRIETARY TO MOLEX INCORPORATED AND SHOULD NOT BE USED WITHOUT WRITTEN PERMISSION					
	SIZE A3					

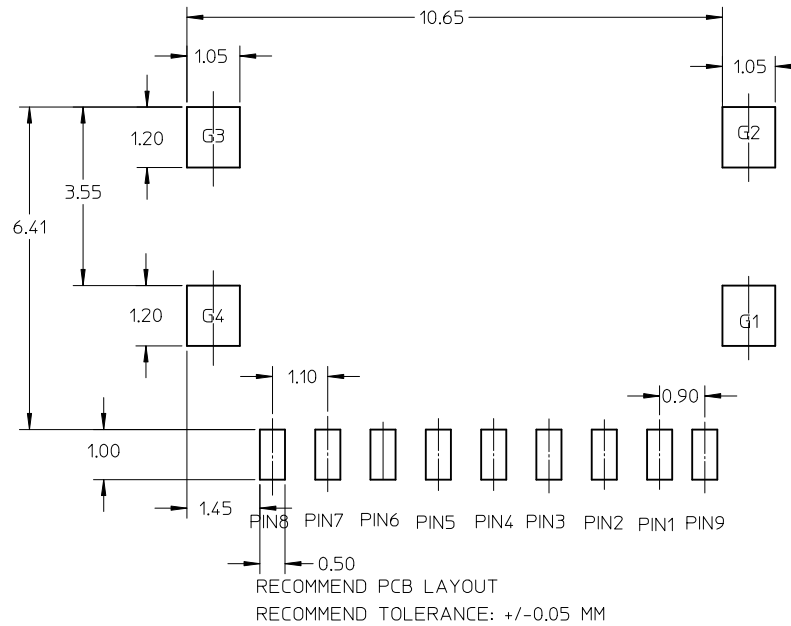

G4	GND
G3	GND
G2	GND
G1	GND
P9	DET
P8	DAT1
P7	DAT0
P6	VSS
P5	CLK
P4	VDD
P3	CMD
P2	CD/DAT3
P1	DAT2
NAME	TYPE
PIN ASSIGNMENT	

SEE SHEET 1 EC NO: SH2012-0261 DRAWN:GLL 2012/02/10 CHKD: APPR:AYIN 2012/02/23	QUALITY SYMBOLS	GENERAL TOLERANCES (UNLESS SPECIFIED)		DIMENSION STYLE MM ONLY		SCALE 1:1	DESIGN UNITS METRIC	THIRD ANGLE PROJECTION	
	$\nabla_F=0$	4 PLACES	mm	INCH	DRAWN BY LIU LEI	DATE 2008/8/10	TITLE 2.0H TFR HEADER WITH SIDE DETECT PIN		
	$\nabla_F=0$	3 PLACES	$\pm$ ---	$\pm$ ---	CHECKED BY WFDENG	DATE 2008/8/10	MOLEX INCORPORATED		
	$\nabla_F=0$	2 PLACES	$\pm$ 0.15	$\pm$ ---	APPROVED BY WFDENG	DATE 2010/02/11	DOCUMENT NO. SD-105078-001	SHEET NO. 2 OF 2	
		1 PLACE	$\pm$ 0.20	$\pm$ ---	MATERIAL NO.		THIS DRAWING CONTAINS INFORMATION THAT IS PROPRIETARY TO MOLEX INCORPORATED AND SHOULD NOT BE USED WITHOUT WRITTEN PERMISSION		
		ANGULAR $\pm$ 2 °		DRAFT WHERE APPLICABLE MUST REMAIN WITHIN DIMENSIONS		SEE SHEET 1			