

# 32-Bit

Microcontroller

## Application Kit TC2X4

Hardware: APPLICATION KIT TC2X4 V1.0

Hardware Manual

### User's Manual

V 1.0 2014-10

## Microcontrollers

**Edition 2014-10**

**Published by  
Infineon Technologies AG  
81726 Munich, Germany**

**© 2014 Infineon Technologies AG  
All Rights Reserved.**

#### **Legal Disclaimer**

The information given in this document shall in no event be regarded as a guarantee of conditions or characteristics. With respect to any examples or hints given herein, any typical values stated herein and/or any information regarding the application of the device, Infineon Technologies hereby disclaims any and all warranties and liabilities of any kind, including without limitation, warranties of non-infringement of intellectual property rights of any third party.

#### **Information**

For further information on technology, delivery terms and conditions and prices, please contact the nearest Infineon Technologies Office ([www.infineon.com](http://www.infineon.com)).

#### **Warnings**

Due to technical requirements, components may contain dangerous substances. For information on the types in question, please contact the nearest Infineon Technologies Office.

Infineon Technologies components may be used in life-support devices or systems only with the express written approval of Infineon Technologies, if a failure of such components can reasonably be expected to cause the failure of that life-support device or system or to affect the safety or effectiveness of that device or system. Life support devices or systems are intended to be implanted in the human body or to support and/or maintain and sustain and/or protect human life. If they fail, it is reasonable to assume that the health of the user or other persons may be endangered.

# 32-Bit

Microcontroller

## Application Kit TC2X4

Hardware: APPLICATION KIT TC2X4 V1.0

Hardware Manual

User's Manual

V 1.0 2014-10

Microcontrollers

---

## Application Kit TC2X4 User's Manual

### Revision History: V 1.0 2014-10

Previous Versions: –

Page	Subjects (major changes since last revision)
–	
–	
–	

### Trademarks

TriCore® is a trademark of Infineon Technologies AG.

#### **We Listen to Your Comments**

Any information within this document that you feel is wrong, unclear or missing at all? Your feedback will help us to continuously improve the quality of this document. Please send your proposal (including a reference to this document) to:

[mcdocu.comments@infineon.com](mailto:mcdocu.comments@infineon.com)



## Table of Contents

<b>1</b>	<b>Introduction</b> .....	1-1
<b>2</b>	<b>Application Kit Features</b> .....	2-1
2.1	Summary of Features .....	2-1
2.2	Block Diagram .....	2-3
2.3	Placement .....	2-4
<b>3</b>	<b>Application Kit Information</b> .....	3-1
3.1	Power Supply .....	3-1
3.1.1	Power via supply connector (X101) .....	3-1
3.1.2	Power via Micro USB (BU301) .....	3-1
3.1.3	Multi Voltage Safety Micro Processor Supply TLF35584QV .....	3-1
3.2	Real Time Clock .....	3-2
3.3	XGA Display .....	3-2
3.3.1	Write a display register .....	3-3
3.3.2	Read a display register .....	3-3
3.3.3	Touch controller .....	3-4
3.4	Micro SD card .....	3-4
3.5	LEDs .....	3-4
3.6	Clock .....	3-4
3.7	USB Connector .....	3-5
3.7.1	Serial Connection to PC .....	3-5
3.7.2	miniWiggler JDS .....	3-5
3.8	Beeper .....	3-5
3.9	MultiCAN .....	3-5
3.10	LIN .....	3-6
3.11	Ethernet (if supported by CPU) .....	3-6
3.12	Core current measurement .....	3-6
3.13	Other peripherals .....	3-6
3.14	Toggle LED's .....	3-6
3.15	Debug System .....	3-6
3.15.1	OCDS1 .....	3-6
<b>4</b>	<b>Signal Description</b> .....	4-1
<b>5</b>	<b>Connector Pin Assignment</b> .....	5-1
5.1	IO Connectors .....	5-1
5.2	Power connector pinout .....	5-2
5.3	USB connector pinout .....	5-2
5.4	CAN connector pinout .....	5-2
5.5	LIN connector pinout .....	5-3
5.6	OCDS connector pinout .....	5-3

5.7	Ethernet Connector .....	5-4
5.8	DAP connector pinout .....	5-4
<b>6</b>	<b>Schematic and Layout .....</b>	<b>6-1</b>
6.1	Schematic .....	6-1
6.2	Layout .....	6-6
6.3	Layout with Dimensioning .....	6-8

## List of Figures

Figure 2-1	Application Kit TC2X4 Block Schematic . . . . .	2-3
Figure 2-2	Application Kit TC2X4 V1.0 Top Placement . . . . .	2-4
Figure 2-3	Application Kit TC2X4 V1.0 Bottom Placement . . . . .	2-5
Figure 5-1	IO Connectors - Pinout . . . . .	5-1
Figure 5-2	Power connector pinout . . . . .	5-2
Figure 5-3	USB connector Pinout . . . . .	5-2
Figure 5-4	CAN connector pinout (IDC10) . . . . .	5-2
Figure 5-5	LIN connector pinout (IDC10) . . . . .	5-3
Figure 5-6	OCDS connector pinout (IDC16) . . . . .	5-3
Figure 5-7	Ethernet connector pinout (RJ45) . . . . .	5-4
Figure 5-8	DAP connector pinout (FTSH10) . . . . .	5-4
Figure 6-1	Schematic - Project . . . . .	6-2
Figure 6-2	Schematic - CPU and Power Supply . . . . .	6-3
Figure 6-3	Schematic - Peripherals . . . . .	6-4
Figure 6-4	Schematic - miniWiggler JDS and OCDS1 . . . . .	6-5
Figure 6-5	Component Plot Top Layer . . . . .	6-6
Figure 6-6	Component Plot Bottom Layer . . . . .	6-7
Figure 6-7	Dimensioning (mm) . . . . .	6-8
Figure 6-8	Dimensioning (mil) . . . . .	6-9





## List of Tables

Table 4-1	Power Signals .....	4-1
Table 4-2	Reset Signals .....	4-1
Table 4-3	Interrupt Signals .....	4-1
Table 4-4	Clock Signals .....	4-2
Table 4-5	Debug Signals .....	4-2
Table 4-6	Peripheral Signals .....	4-2





## 1 Introduction

We congratulate you on your purchase of the TriCore Evaluation Board. This kit is a versatile tool, providing quick access to the capabilities of TriCore's powerful architecture.

Applications can be developed easily. The Application Kit is equipped with a variety of peripherals for connection to the environment. There is also an interface for the On Chip Debugging Features.

The Application Kit allows easily the development of TriCore applications with the corresponding tools.

Subsequently, the applications can be downloaded and can be tested with the powerful debugger software.

This Application Kit Hardware Manual familiarizes you with the TriCore Evaluation Board and guides you through the initial configuration of the Application Kit.

For detailed technical information about the TC2X4 (e.g. TC234, TC224) please refer to the User Manual of the device.



## 2 Application Kit Features

### 2.1 Summary of Features

- Infineon's TC2X4 (e.g. TC234, TC224) Controller in TQFP-144 Package
- LCD XGA Display 320x240
- SD card slot (mini SD)
- High Speed CAN Transceivers
- USB to UART bridge
- Ethernet Gigabit PHY (if Ethernet supported by assembled CPU)
- LIN Transceiver
- Crystal 20MHz (default) or External Clock
- USB miniWiggler JDS for easy debugging
- 4 Low Power Status LEDs
- RTC with alarm
- Acoustic beeper
- 100mm x 100mm

### Connectors

The Application Kit TC2X4 Offers a wide variety of connectors:

- Standard power connector
- Micro USB connector for ASC Interface (ASC0) and miniWiggler
- RJ45 connector for Ethernet (if Ethernet supported by assembled CPU)
- 16-pin header for JTAG interface (OCDS)
- 10-pin header for DAP
- 10pin (2x5) Header for LIN Transceiver (LIN)
- 10pin (2x5) Header for CAN High Speed Transceiver (CAN0)
- two 40-pin connectors with I/O signals
- mini SD card slot

### Components

- Infineon's Multi Voltage Safety Micro Processor Supply TLF35584QV
- LED to validate power supply (3,3Volt)
- LED indicating RESET (ESR0) active state
- LED indicating activ miniWiggler JDS
- LED switched via DAS software
- Infineon's High Speed CAN-Transceiver TLE 6250 GV33
- Infineon's LIN-Transceiver TLE 7259-2GE
- QSPI Real-Time Clock/Calendar with SRAM and unique MAC Id MCP79511
- USB to UART bridge FT2232HL (FTDI)

**Application Kit Features**

- Single Port Gigabit Ethernet PHY PEF7071 (LANTIQ, if Ethernet supported by assembled CPU)
- Touch screen controller ADS7843
- 4 general purpose LEDs
- Reset switch
- Wake switch
- Xilinx CPLD XC9572XL

## 2.2 Block Diagram

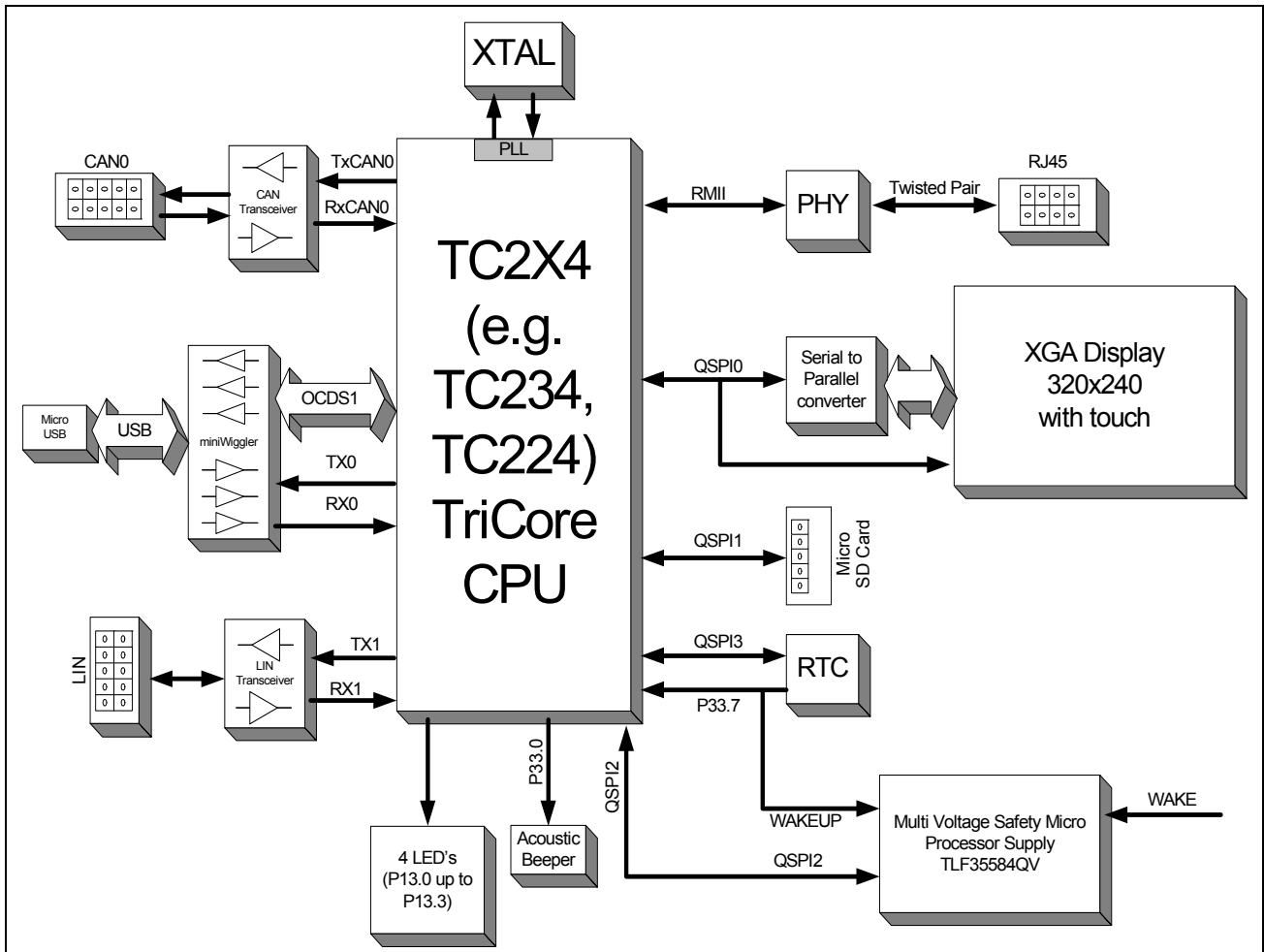

Figure 2-1 Application Kit TC2X4 Block Schematic



## 2.3 Placement

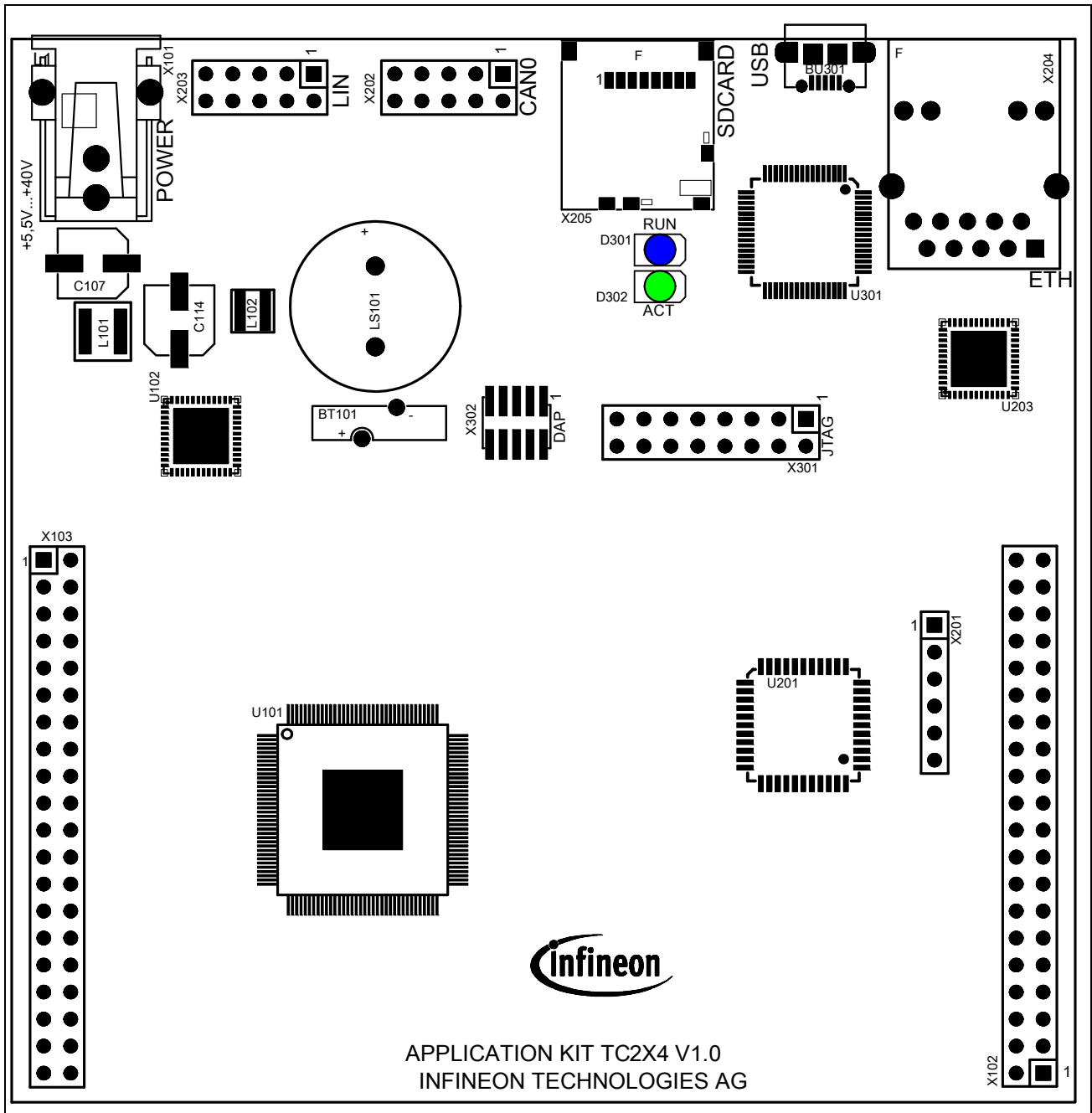

Figure 2-2 Application Kit TC2X4 V1.0 Top Placement

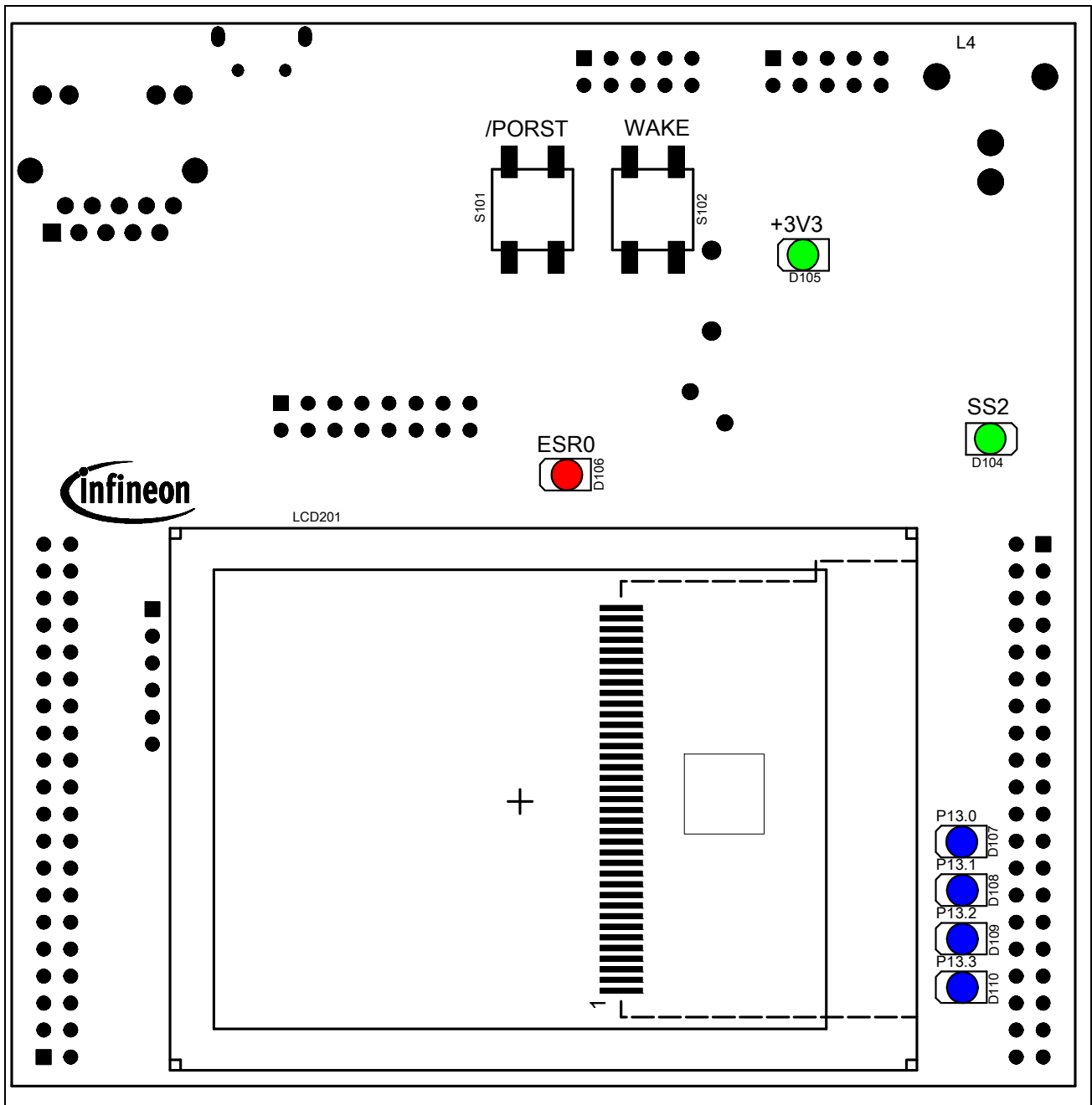

Figure 2-3 Application Kit TC2X4 V1.0 Bottom Placement



## 3 Application Kit Information

### 3.1 Power Supply

The microcontroller needs 3 different supply voltages. This voltages are generated via Infineon's Multi Voltage Safety Micro Processor Supply TLF35584QV (+3,3V and +5V volt for ADC and CAN) and via the microcontroller itself (+1,3V).

Applying a stable supply voltage causes the power on reset after a short period. The LED' (+3V3) indicate the status of the 3,3V voltage.

The board can be powered directly by USB or by the power connector. In case that the voltage on the power connector is higher than the 5V from the USB then the board is powered by power connector.

A manual power on reset is executed by pressing the reset button.

#### 3.1.1 Power via supply connector (X101)

The Board has to be connected to a +5,5V to +40V DC power supply.

A supply with 6V and 500mA is sufficient. The pinout for the supply connector is shown in [Figure 5-2](#). There can be used any standard power pack with a connector where the positive line is surrounded by the ground line.

#### 3.1.2 Power via Micro USB (BU301)

The Board can also be powered by the Micro USB connector. The power consumption of the board is approx. 400mA. Use an USB port which can deliver 500mA (USB 2.0) or 900mA (USB 3.0). Most USB hubs are not able to drive more than 100mA and can't be used.

Also it is possible to power the board with a cellular battery charger which has 5V output and use Micro USB for connecting.

The pinout for the USB connector is shown in [Figure 5-3](#).

#### 3.1.3 Multi Voltage Safety Micro Processor Supply TLF35584QV

The board has assembled the Safety Micro Processor Supply with the following Features:

- High efficient multi voltage power supply chip
- Serial step up and step down pre regulator for wide input voltage range from 3.0 to 40 V with full performance and low over all power loss
- Low drop post regulator 5.0V/200mA for communication supply (named LDO\_Com)
- Low drop post regulator 3.3 V/600 mA (VS2) for  $\mu$ C supply (named LDO\_ $\mu$ C)
- Provides enable, sync out signal and voltage monitoring (inside device to be added to reset function) for an optional external post regulator for core supply (not used)

**Application Kit Information**

- Voltage reference 5.0 V +/- 1% for ADC supply, 150 mA current capability (named Volt\_Ref)
- Two trackers for sensor supply following voltage reference 150 mA current capability each (named Tracker 1 and Tracker 2, not used)
- Standby regulator 3.3 V/10 mA (VS2) (named LDO\_Stby)
- Independent voltage monitoring block with reset function
- Configurable functional and window watchdog
- 16-bit SPI
- Safe state control with two safe state signals with programmable delay
- Input voltage monitoring (over voltage switch off)
- Green Product (RoHS compliant)
- ISO26262 compliant
- AEC Qualified

The TLF35584 is connected to the CPU via QSPI2 and use QSPI2\_SLSO1 (P14.2) as chip select. Via this spi connection the power supply will be configured (Watchdog, device states and soon).

For more information see the data sheet of TLF35584. Because the TC234 and TC224 are 3,3V devices we use the 3,3V version of the TLF35584 (VS2).

### **3.2 Real Time Clock**

The board is equipped with a RTC MCP79511 from Microchip. The device is powered from the standby voltage of the TLF35584 and is also powered when the TLF35584 is switched to standby mode. For backup when the TLF35584 is not powered then there is a small battery to hold the value inside the RTC. The RTC is connected to the microcontroller via QSPI3 and can trigger an SCU\_REQ8 (P33.7) interrupt (activ high) with the alarms. Also an alarm from the RTC will wake-up (switch on) the board if the board is powered and the supply is switched off.

The MCP79511 contains also an unique ID in the format EUI-48. This id can be used as mac id for ethernet if the assembled CPU support ethernet.

For more information about the RTC please see the datasheet of MCP79511.

### **3.3 XGA Display**

The board has an XGA Display with a resolution of 320x240. The display has an ILI9341 display controller. Please see the datasheet of the display controller for the register of the controller. The display is connected to the the microcontroller via an SPI to Parallel converter (U201).

The SPI to Parallel converter is based on a statemachine. This state machine is clocked with the clock of SPI, here SCLK0 (P20.11). Each rising edge of P20.11 will change the state of statemachine. When SLSO08 (P20.6) is not low then the state machine will go always in the idle state with a valid clock edge.

### 3.3.1 Write a display register

A single write to any register can be done by a 32 bit transfer of SPI. Make sure that the SLSO08 is low during this 32 bit. Bit 31 must be transferred first.

Bit 31 must be 0, this will be indicate a write access.

Bit 30 must be 0, this will be indicate a single access.

Bit 29...Bit 22 is the 8 bit register number which will be written

Bit 21...Bit 6 is the 16bit value which will be written

Bit 5...Bit 0 are dummy bits which are used to execute the write.

To speedup the writing (e.g. write to ram of display controller) it is possible to make a endless transfer. This is done by this:

first 10 bit transfer

Bit 9 must be 0, this will be indicate a write access.

Bit 8 must be 1, this will be indicate an endless transfer.

Bit 7...Bit 0 is the 8 bit register number which will be written

Now you need to transfer only 16bit values for the registers. With the first 16 bit value there is no action on the display. With the second value transfer is a write to the register started. This means after the last value you must make a dummy transfer to write the last value.

The endless mode can only be leave by a rising edge of SCLK0 with SLSO08 set to high. This can be done by a dummy transfer to any other chip select or by a transfer from the touch controller.

### 3.3.2 Read a display register

A single read from any register can be done by a 32 bit transfer of SPI. Make sure that the SLSO08 is low during the complete transfer.

first transfer has 16 bit:

Bit 15 must be 1, this will be indicate a read access.

Bit 14 must be 0, this will be indicate a single access.

Bit 13...Bit 7 is the 8 bit register number which will be read

Bit 5...Bit 0 are dummy bits to setup the register number.

second transfer must have 26 bits:

Bit 25...Bit 16 are dummy bits which are needed to readout the register value

Bit 15...Bit 0 are dummy bits to transfer the readed value.

To speedup the reading (e.g. reading from ram of display controller) it is possible to make a endless transfer. This is done by this:

first 16 bit transfer:

first transfer has 16 bit:

Bit 15 must be 1, this will be indicate a read access.

Bit 14 must be 1, this will be indicate an endless access.

Bit 13...Bit 7 is the 8 bit register number which will be read

Bit 5...Bit 0 are dummy bits to setup the register number.

second 10 bit transfer:

Bit 9...Bit 0 are dummy bits which are needed to readout the register value

Now you need to transfer only 16bit values for the registers. With the each 16 bit transfer you get a value. With the last transfer you have dummy read which you don't get the result.

The endless mode can only be leave by a rising edge of SCLK0 with SLSO08 set to high. This can be done by a dummy transfer to any other chip select or by a transfer from the touch controller.

### 3.3.3 Touch controller

The touch of display is connected to an Touch controller ADS7843. This controller is connected via the QSPI0 and SLSO9 to the microcontroller. For more information about the delivered values from the touch controller please see the datasheet of ADS7348.

### 3.4 Micro SD card

The board has a slot to use the board with an micro SD card. The card will be used in SPI mode only. The SD is connected to QSPI1 with chip select 9 (P10.5) of QSPI1.

Please see additional literature how to use a SD card in SPI mode.

### 3.5 LEDs

There are 8 LEDs on board:

- D107 up to D110 (blue) -> toggle LEDs connected to P13.0 ... P13.3
- D106 ESR0 (red) -> RESET LED indicate the reset state of the board
- D105 +3V3 (green) -> +3,3V power supply indication
- D104 SS2 (green) -> safe state signal 2 of TLF35584
- D302 ACT (green) -> on board miniWiggler JDS is ACTIV
- D301 RUN (blue) -> Debug RUN mode (switched by DAS Server)

### 3.6 Clock

On the board is a fixed crystal wiith 20MHz assembled. You can change this by replacing Y101 (soldered).

### 3.7 USB Connector

The USB connector is used for connection to a PC. Via the USB it is possible to power the board, using the ASCLIN0 as serial connection via USB and Debugging via DAS. For the pinout of USB socket see [Figure 5-3](#).

NOTE: Before connecting the board to the PC, make sure that the actual DAS software is installed on the PC. For actual DAS software please contact your local FAE.

The software can also be found on the

[DAS website](#)

#### 3.7.1 Serial Connection to PC

After the first connection of USB to a PC the needed driver will be installed automatically. During this there will be created a new COM port on PC. This COM port can be used to communicate with the board via ASC0 of the device (e.g. bootstrap loader).

#### 3.7.2 miniWiggler JDS

The miniWiggler JDS is a low cost debug tool which allows you access to the JTAG of the device. Make sure that you have the latest DAS release. Debugging is possible via the DAS Server 'UDAS'. Please contact your preferred debug vendor for support of DAS.

If you have connected the board to the PC and there runs the DAS server, then a working connection is visible via the green ACTIV LED.

The status RUN LED is switched on/off through the DAS Server, depending on the used debugger (client).

IMPORTANT: Make sure that there is no or a tristated connection on X301 (OCDS1) if the ACTIV LED is on.

### 3.8 Beeper

The board has an electro-acoustic transducer which can be used for an acoustic output. The transducer is connected to pin P33.0 and needs a 2048Hz frequency.

### 3.9 MultiCAN

On the board is oneCAN transceiver connected to the MultiCAN on TC2X4 node 0. The transceiver is connected to an IDC10 plug. For the pinout of IDC10 plug see [Figure 5-4](#). You can use a IDC female connector with crimpconnector, flat cable and SUB-D 9 plug with crimpconnector to have a 1:1 adapter to SUB-D 9.



### 3.10 LIN

On the board is one LIN transceiver connected to the ASCLIN1 on TC2X4. The transceiver are connected to one IDC10 plug. For the pinout of IDC10 plug see [Figure 5-5](#). You can use a IDC female connector with crimpconnector, flat cable and SUB-D 9 plug with crimpconnector to have a 1:1 adapter to SUB-D 9.

### 3.11 Ethernet (if supported by CPU)

The Application Kit provide a RJ45 connector (X204) for twisted pair ethernet connections. The board use a Lantiq Giagabit PHY PEF7071 as physical interface device.

The parts for ethernet are only assembled if the assembled CPU support ethernet.

For more information about the ethernet modul see TC2X4 User's Manual, about the PHY see the PEF7071 datasheet. For the pinout of RJ45 see [Figure 5-7](#).

### 3.12 Core current measurement

It is possible to measure the core (+1,3V) current with two ADC pins of the CPU. This can be done by synchronous measurement of AN10 and AN22. The pins are connected together by an 50mOhm resistor. The current can be calculated by the following formula:

$I_{\text{core}} = (V_{\text{AN10}} - V_{\text{AN22}}) / 0,05$ . To get an valid result the measurement must be done synchronous.

### 3.13 Other peripherals

For all other peripherals there are no special plugs on the board. Many of the peripheral signals are available on the two standard connectors X102 and X103. See [“Connector Pin Assignment” on Page 5-1](#).

### 3.14 Toggle LED's

Port 13 pin 0 up to pin 3 are connected to single LED's (D107... D110) and can be controlled by Software. This status LED's are low active.

### 3.15 Debug System

#### 3.15.1 OCDS1

The OCDS1 signals are connected to the IDC16 plug (X301). They work with the port supply of +3.3V. For pinout of the connector see [Figure 5-6](#). You can connect any debugger to this connector.

f you connect a debug hardware make sure that the miniWiggler JDS (see [“miniWiggler JDS” on Page 3-5](#)) is not activ (ACTIV LED is off).

**Application Kit Information**

If the ACTIV LED is on, then stop the active DAS Server 'UDAS' and/or remove the USB connection to the PC.



## 4 Signal Description

For more information about the signals please see the user manuals for TC2X4 and/or the schematics of the board.

**Table 4-1 Power Signals**

Short Name	Description
VCC_IN	Supply Input (5,5V...50V(40V))
VIN	Input voltage of power supply device
GND	Ground
VDD	Core Supply Voltage (1,3V)
VDDP3	Port Supply Voltage (3,3V)
VSSOSC	Oscillator Ground
VSSM	ADC Analog Part Ground
VDDM	ADC Analog Part Supply Voltage (VREF_5V, 5V or 3,3V)
VAGND	ADC Reference Ground
VAREF	ADC Reference Voltage (VREF_5V or 3,3V)
VDD_FT	Supply Voltage FT2232HL device (3,3V)
VDD_USB	USB Supply Voltage (5V)

**Table 4-2 Reset Signals**

Short Name	Description
/PORST	Power On Reset
/ESR0	External Service Request 0 (Hardware Reset)
/ESR1	External Service Request 1 (Non Maskable Interrupt)

**Table 4-3 Interrupt Signals**

Short Name	Description
REQ1 / P15.8	External Trigger Input 1
REQ3 / P10.3	External Trigger Input 3
REQ5 / P10.8	External Trigger Input 5
REQ8 / P33.7	External Trigger Input 8 (RTC alarm activ)
REQ9 / P20.0	External Trigger Input 9(Touch activ)
REQ11 / P20.9	External Trigger Input 11 (MD Interrupt)

**Table 4-4 Clock Signals**

Short Name	Description
XTAL1	Crystal Oscillator Input
XTAL2	Crystal Oscillator Output

**Table 4-5 Debug Signals**

Short Name	Description
/TRST	Test Reset
TCK / DAP0	Test Clock / Device Access Pin 0
TMS / DAP1	Test Mode Select / Device Access Pin 1
TDI / P21.6	Test Data Input
TDO / P21.7	Test Data Output
/TESTMODE / P20.2	Test Mode Select Input

**Table 4-6 Peripheral Signals**

Short Name	Description
P14.1	Receive Data ASCLIN0
P14.0	Transmit Data ASCLIN0
P15.1	Receive Data ASCLIN1
P15.0	Transmit Data ASCLIN1
SCLK0 / P20.11	Clock Line SSC0
MRST0A / P20.12	Master Receive / Slave Transmit QSPI0
MTR0 / P20.14	Master Transmit / Slave Receive QSPI0
SLSO08 / P20.6	Slave Select Output 8 (QSPI0)
SLSO09 / P20.3	Slave Select Output 9 (QSPI0)
SCLK1 / P10.2	Clock Line QSPI1
MRST1A / P10.1	Master Receive / Slave Transmit QSPI1
MTR1 / P10.3	Master Transmit / Slave Receive QSPI1
SLSO19 / P10.5	Slave Select Output 9 (QSPI1)
SCLK2 / P15.3	Clock Line QSPI2
MRST2B / P15.7	Master Receive / Slave Transmit QSPI2
MTR2 / P15.5	Master Transmit / Slave Receive QSPI2
SLSO21 / P14.2	Slave Select Output 1 (QSPI2)

**Table 4-6 Peripheral Signals**

SCLK3 / P22.3	Clock Line QSPI3
MRST3E / P22.1	Master Receive / Slave Transmit QSPI3
MTSR3 / P22.0	Master Transmit / Slave Receive QSPI3
SLSO313 / P23.1	Slave Select Output 13 (QSPI3)
P20.8	CAN Transmitter Output 0
P20.7	CAN Receiver Input 0
P21.2	Ethernet MDC
P21.3	Ethernet MDIO
P11.2	Ethernet TXD1
P11.3	Ethernet TXD0
P11.6	Ethernet TXEN
P11.9	Ethernet RXD1
P11.10	Ethernet RXD0
P11.11	Ethernet CRSDIV
P11.12	Ethernet REFCLK
AN[0...23]	Analog Inputs
P33,0	Beeper output (2048Hz)
P13[0...3]	On board LED's



## 5 Connector Pin Assignment

The Application Kit will be shipped with two 40 pin male (plug) connectors on top layer with a standard grid of 2,54mm.

### 5.1 IO Connectors

X102			X103		
VCC_IN	1	2	+3V3	1	2
GND	3	4	GND	3	4
AN7	5	6	AN6	5	6
AN5	7	8	AN4	7	8
AN3	9	10	AN2	9	10
AN1	11	12	AN0	11	12
P33.5	13	14	P33.4	13	14
P33.3	15	16	P33.2	15	16
P33.1	17	18	P33.12	17	18
P33.8	19	20	P33.6	19	20
P34.0	21	22	P34.1	21	22
P34.2	23	24	P34.3	23	24
P22.4	25	26	P33.11	25	26
P22.0	27	28	P22.1	27	28
P22.2	29	30	P22.3	29	30
P15.2	31	32	P15.3	31	32
P15.4	33	34	P15.5	33	34
P15.6	35	36	P15.7	35	36
P20.9	37	38	P20.10	37	38
P14.4	39	40	P14.5	39	40
			VCC_IN	1	2
			GND	3	4
			P33.10	5	6
			P14.8	7	8
			P14.6	9	10
			P20.2	11	12
			P02.0	13	14
			P02.2	15	16
			P02.4	17	18
			P02.6	19	20
			P02.8	21	22
			P00.1	23	24
			P00.3	25	26
			P00.5	27	28
			P00.7	29	30
			P00.9	31	32
			P21.5	33	34
			AN17	35	36
			AN15	37	38
			AN14	39	40
			+3V3		
			GND		
			P33.9		
			P14.7		
			P10.6		
			P11.8		
			P02.1		
			P02.3		
			P02.5		
			P02.7		
			P00.0		
			P00.2		
			P00.4		
			P00.6		
			P00.8		
			P21.4		
			P00.12		
			AN16		
			AN13		
			AN12		

Figure 5-1 IO Connectors - Pinout



### 5.2 Power connector pinout

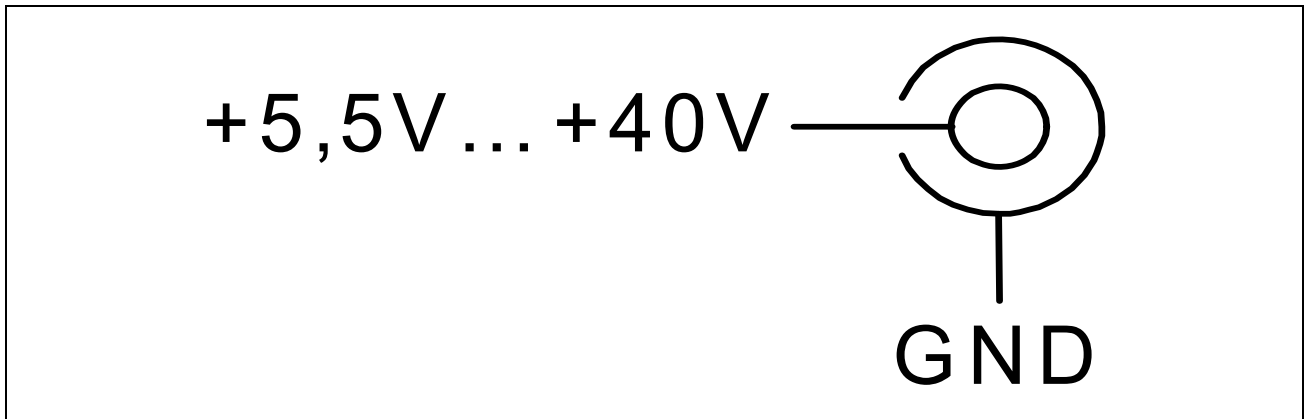

Figure 5-2 Power connector pinout

### 5.3 USB connector pinout

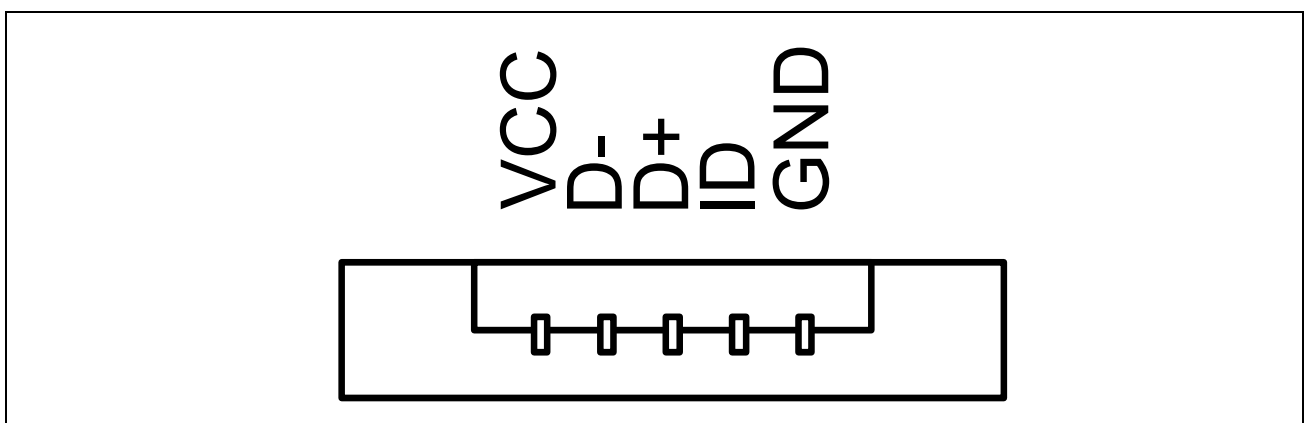

Figure 5-3 USB connector Pinout

### 5.4 CAN connector pinout

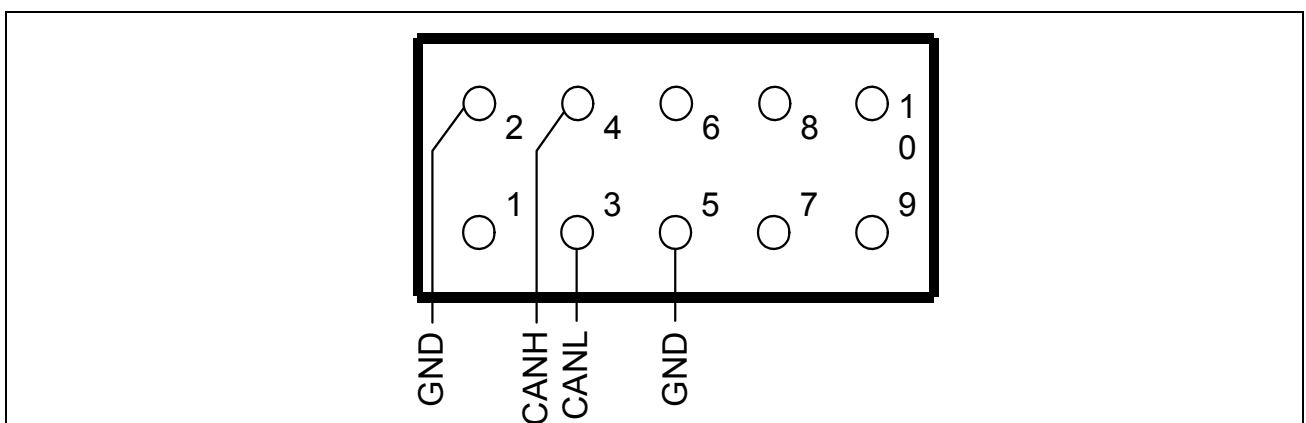

Figure 5-4 CAN connector pinout (IDC10)

### 5.5 LIN connector pinout

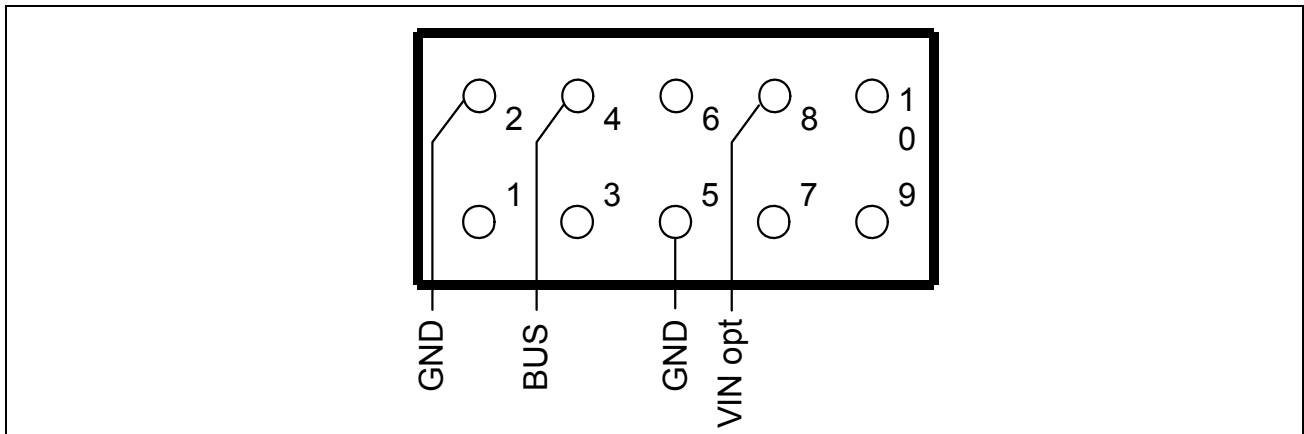

Figure 5-5 LIN connector pinout (IDC10)

### 5.6 OCDS connector pinout

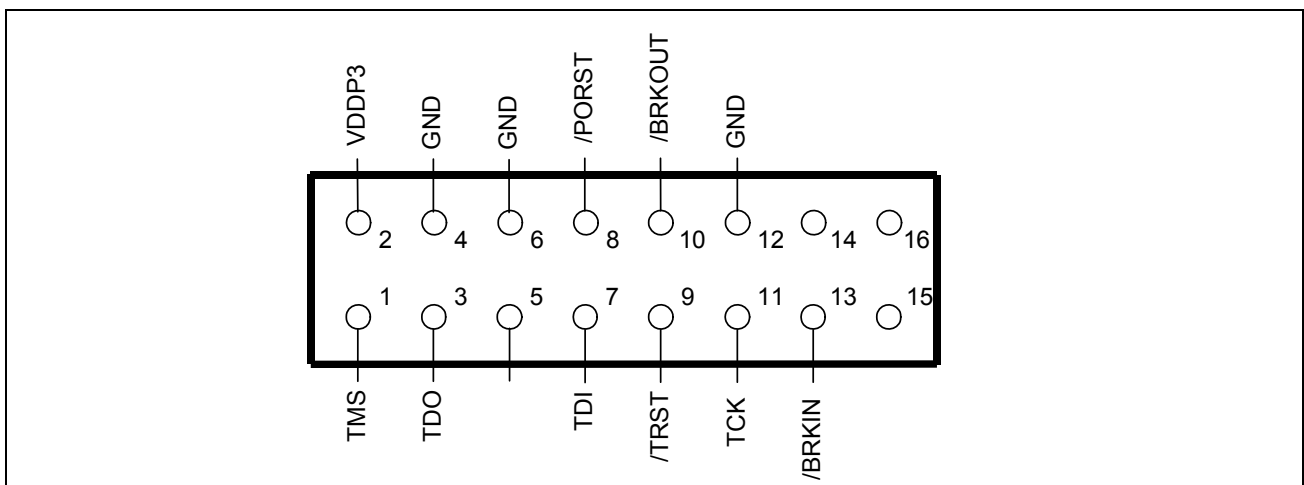

Figure 5-6 OCDS connector pinout (IDC16)

### 5.7 Ethernet Connector

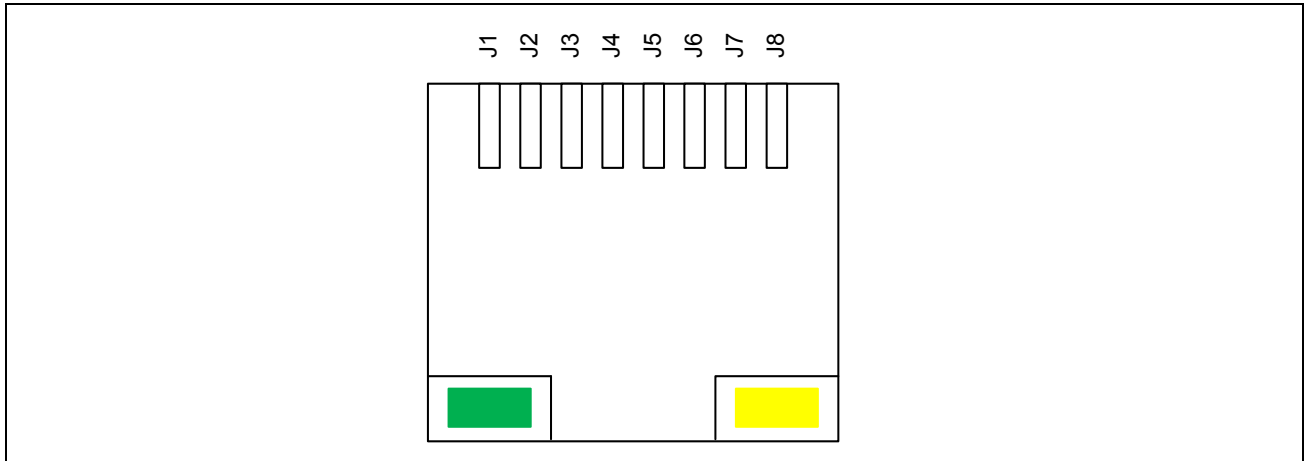

Figure 5-7 Ethernet connector pinout (RJ45)

### 5.8 DAP connector pinout

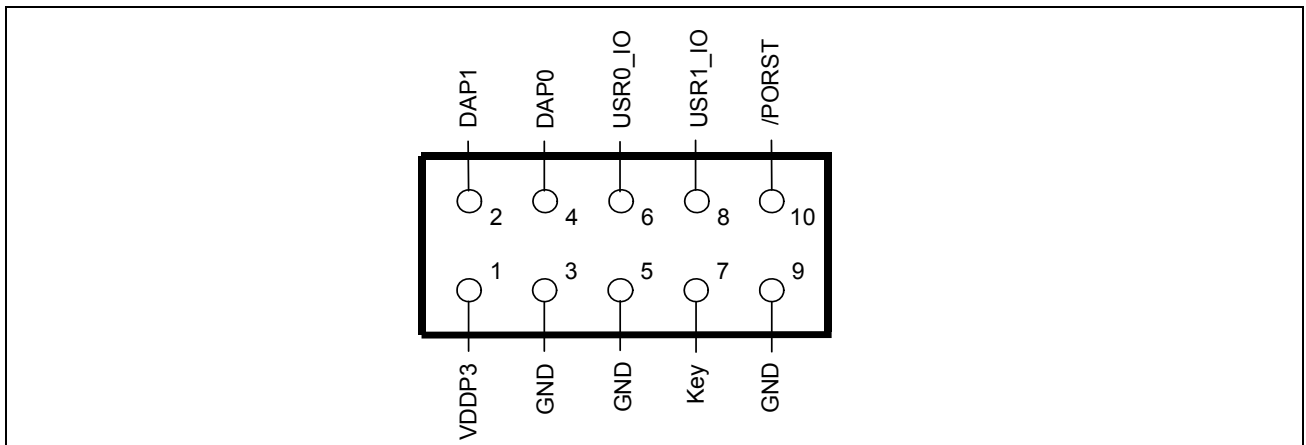
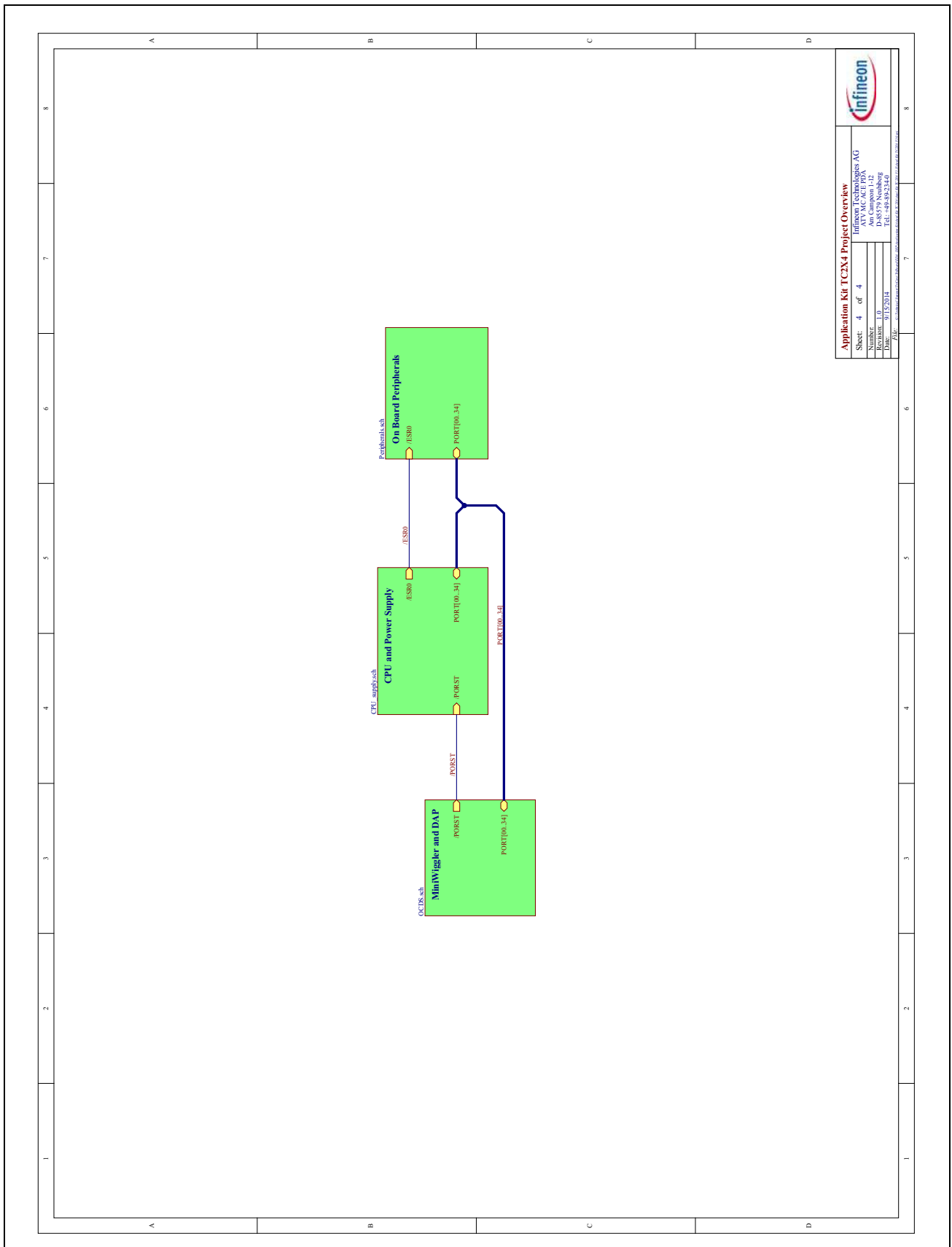

Figure 5-8 DAP connector pinout (FTSH10)

## 6 Schematic and Layout

### 6.1 Schematic



**Figure 6-1 Schematic - Project**

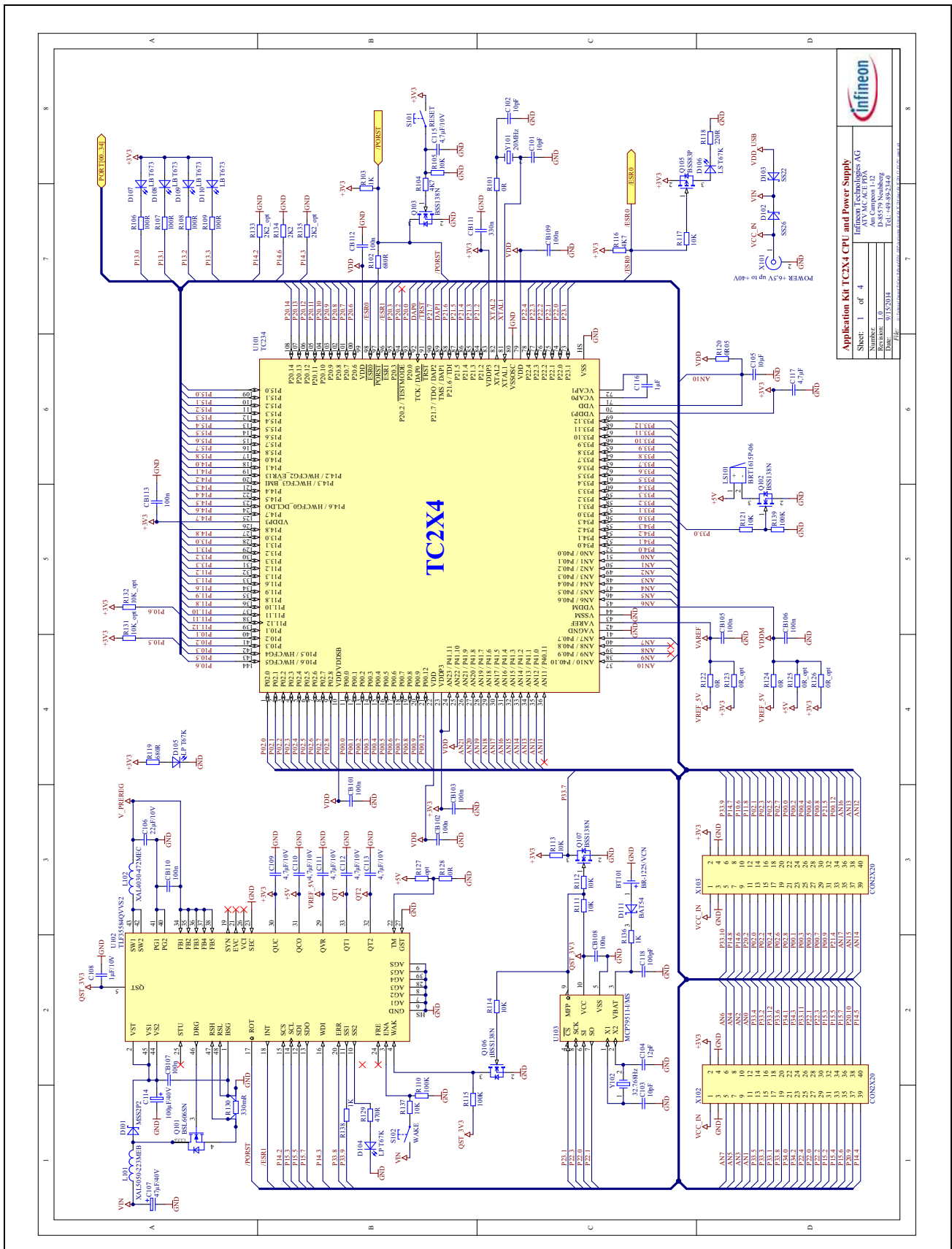

**Infineon**

Application Kit TC2X4 CPU and Power Supply

Sheet: 1 of 4

Infineon Technologies AG

AVC AC/DC/DA

AVC CPU/PLD

DA-8579 Neuburg

Doc. No. 91T320H

Rev. 1.0

Replaces: -

Date: 2014-10-24

Tel.: +49-9249-2340

**Figure 6-2 Schematic - CPU and Power Supply**

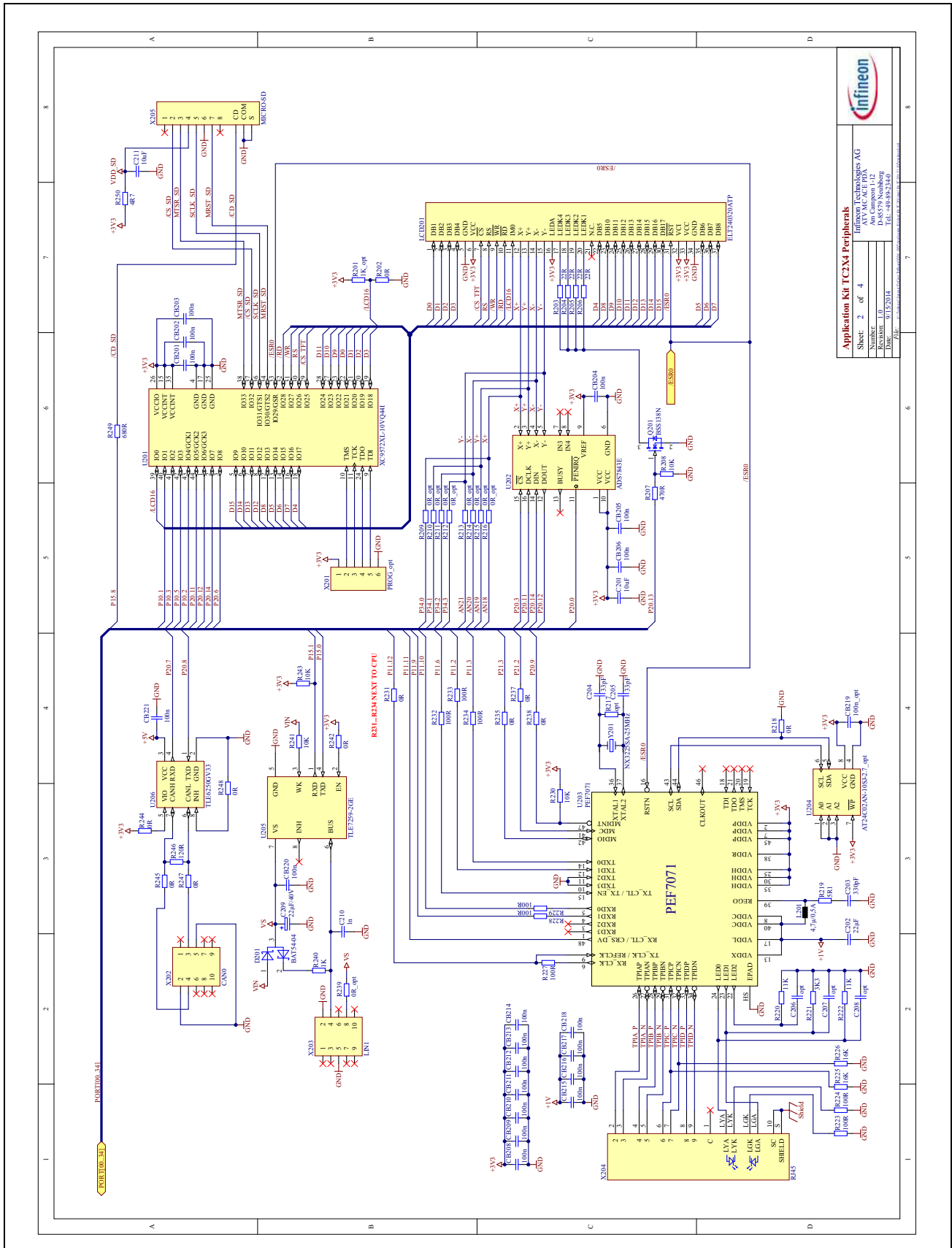

Figure 6-3 Schematic - Peripherals

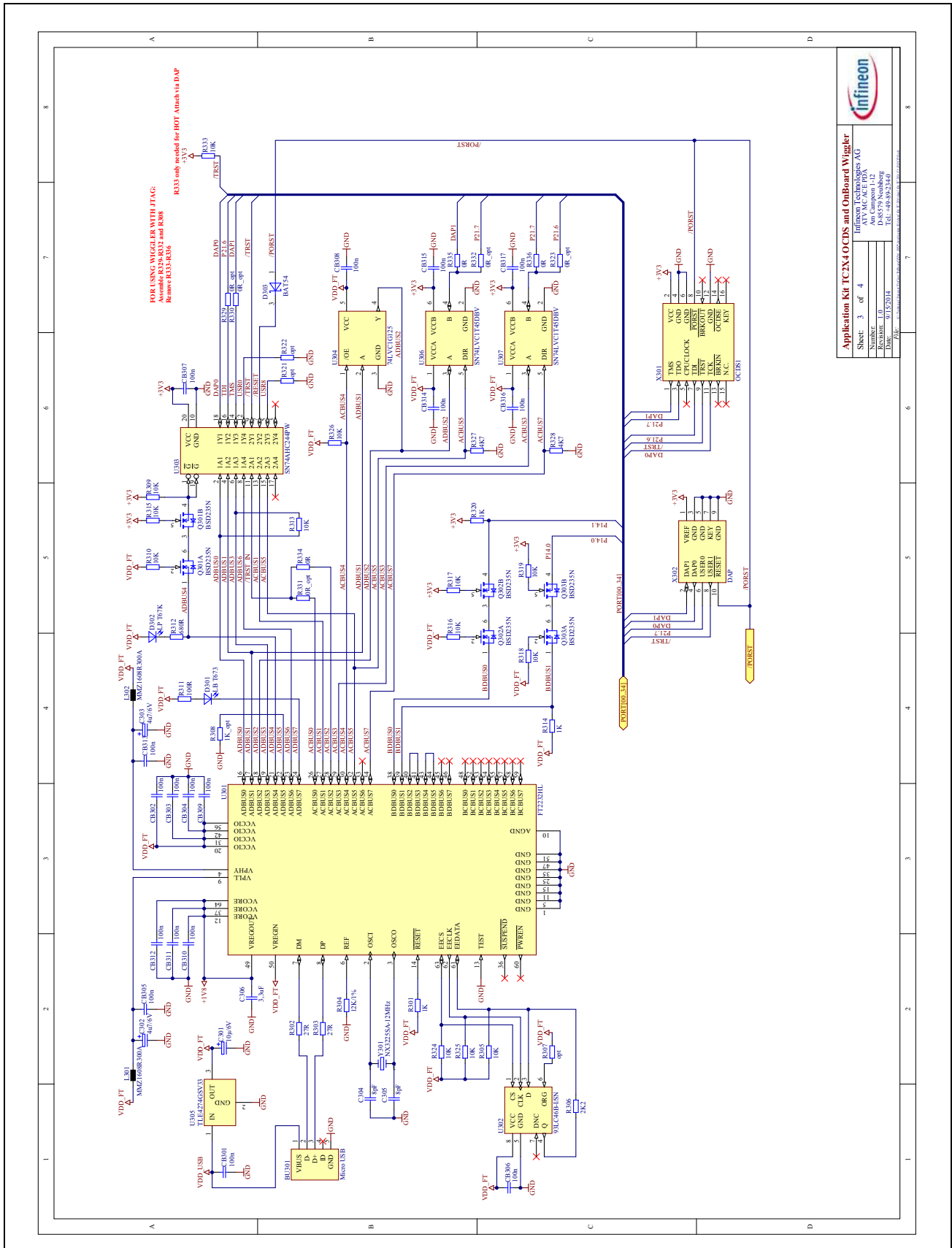

Figure 6-4 Schematic - miniWiggler JDS and OCDS1



## 6.2 Layout

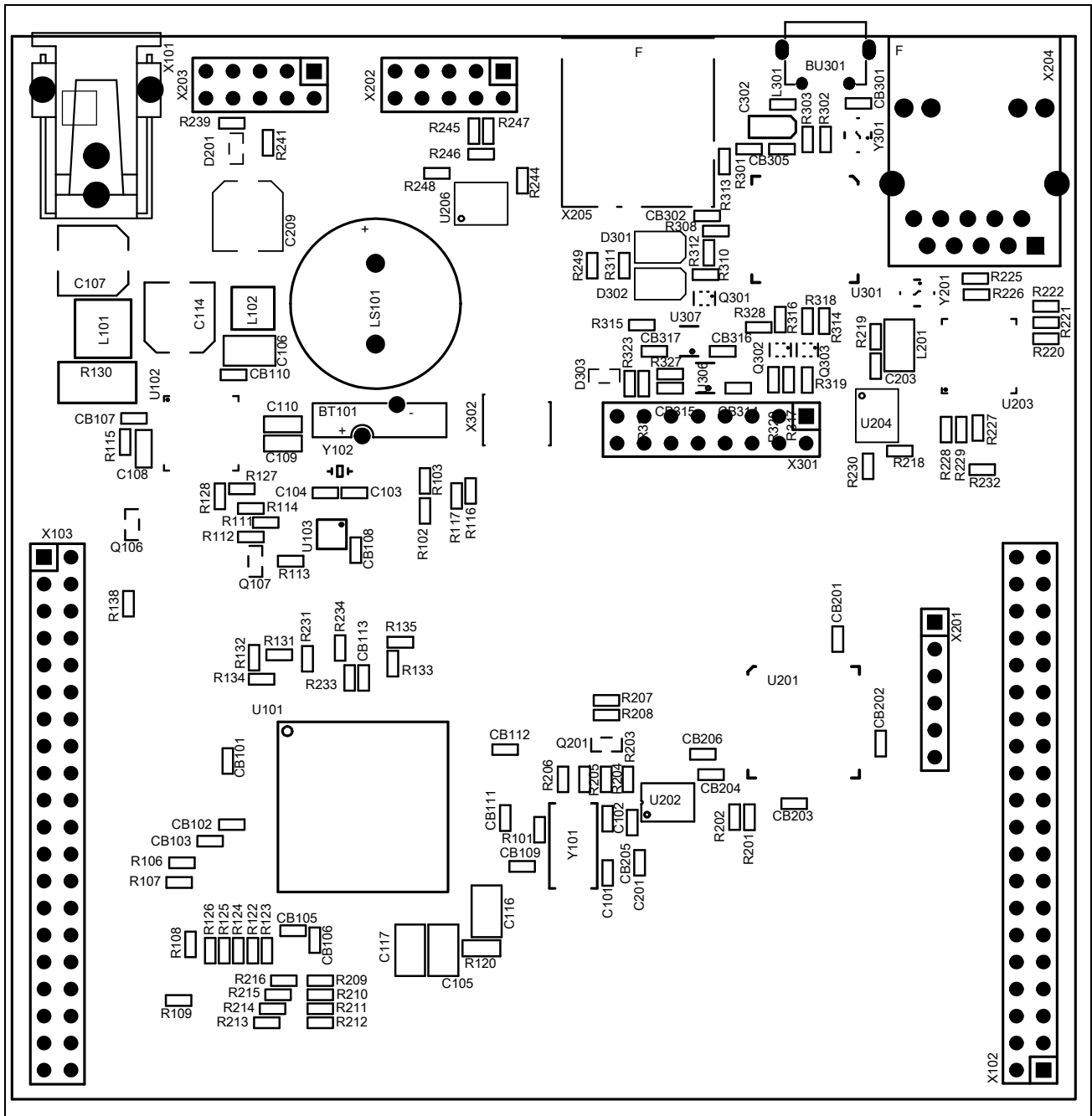

Figure 6-5 Component Plot Top Layer

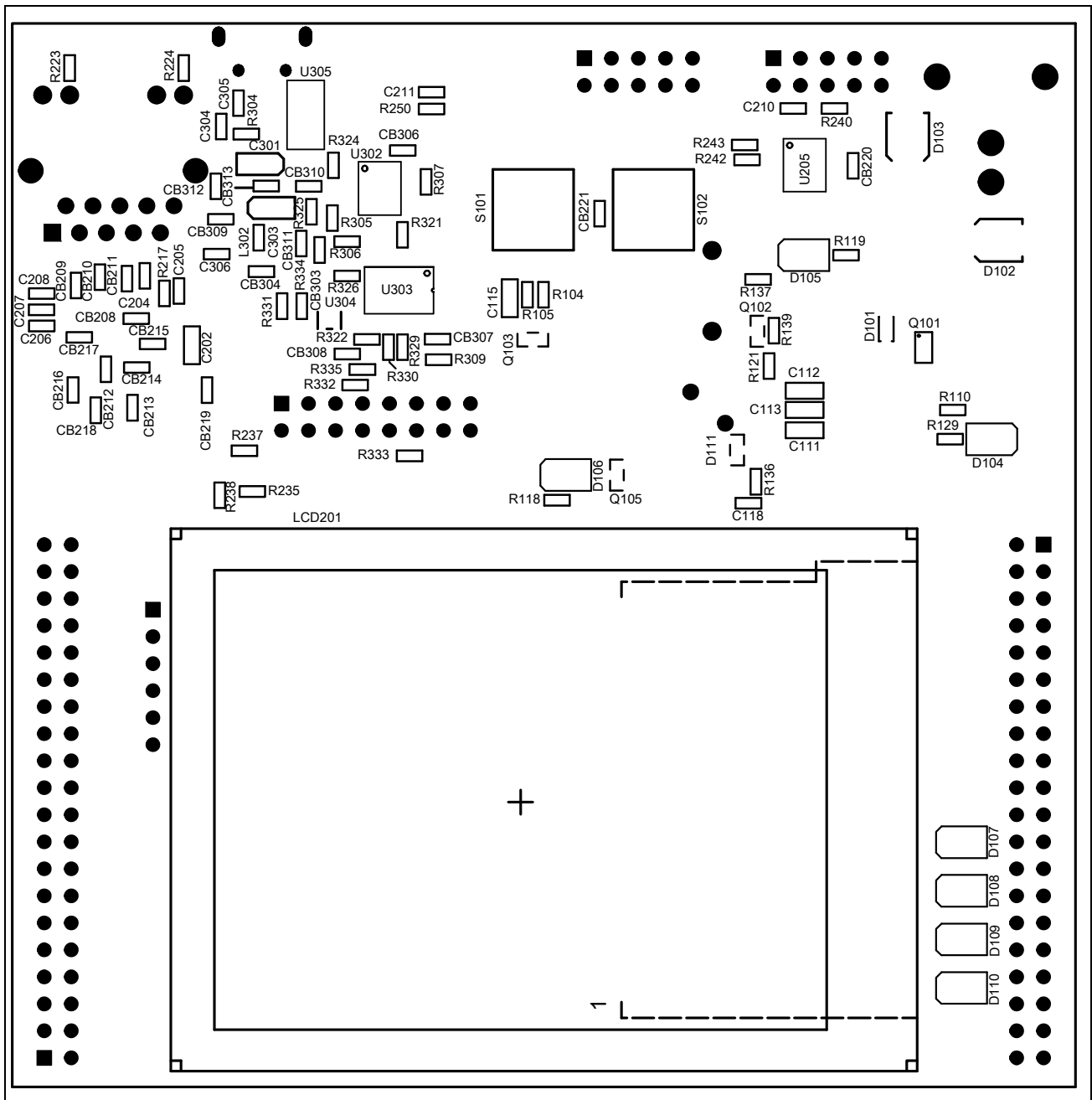

Figure 6-6 Component Plot Bottom Layer

### 6.3 Layout with Dimensioning

The following dimensions should be used for development of extension boards.

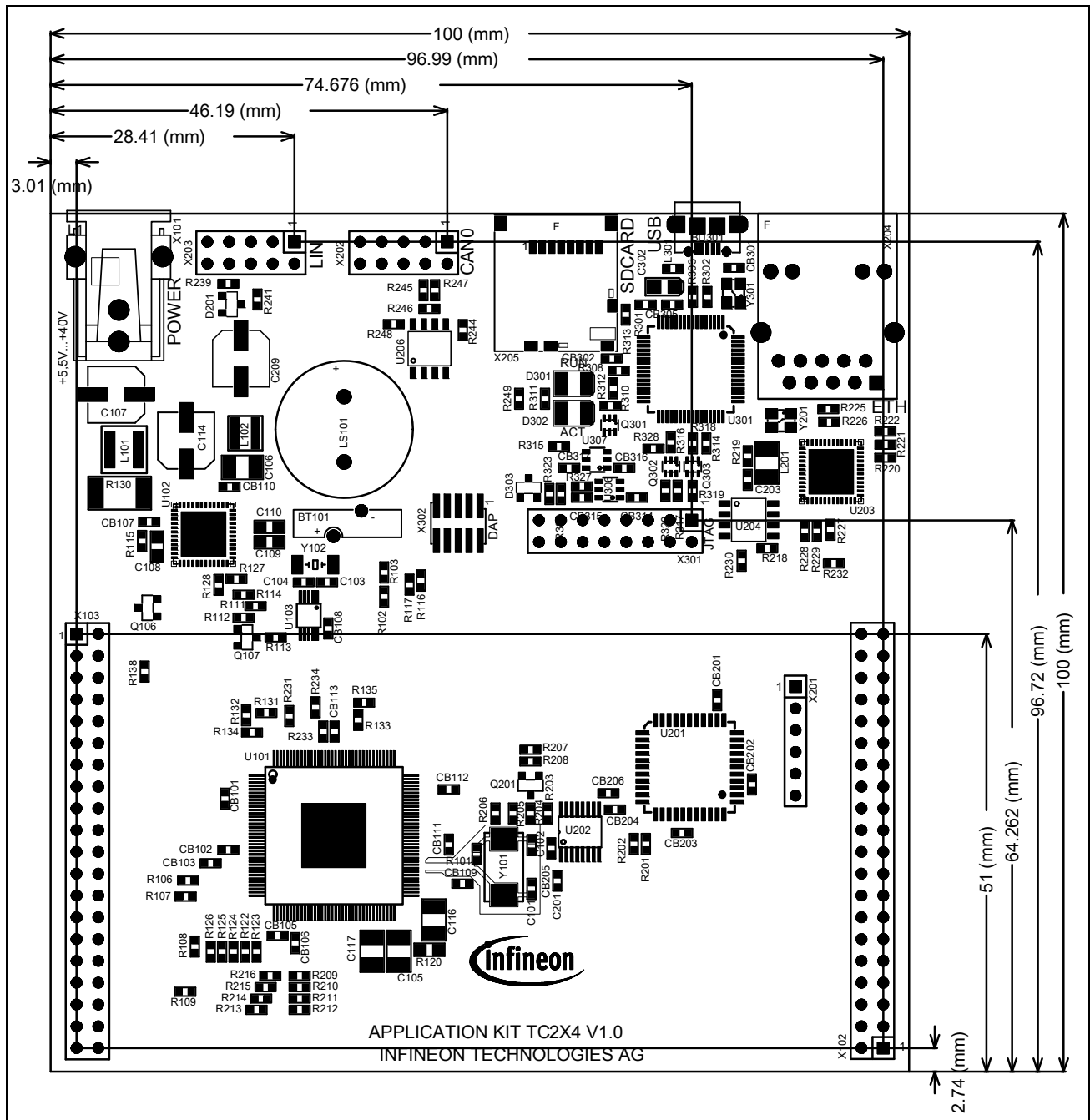

Figure 6-7 Dimensioning (mm)

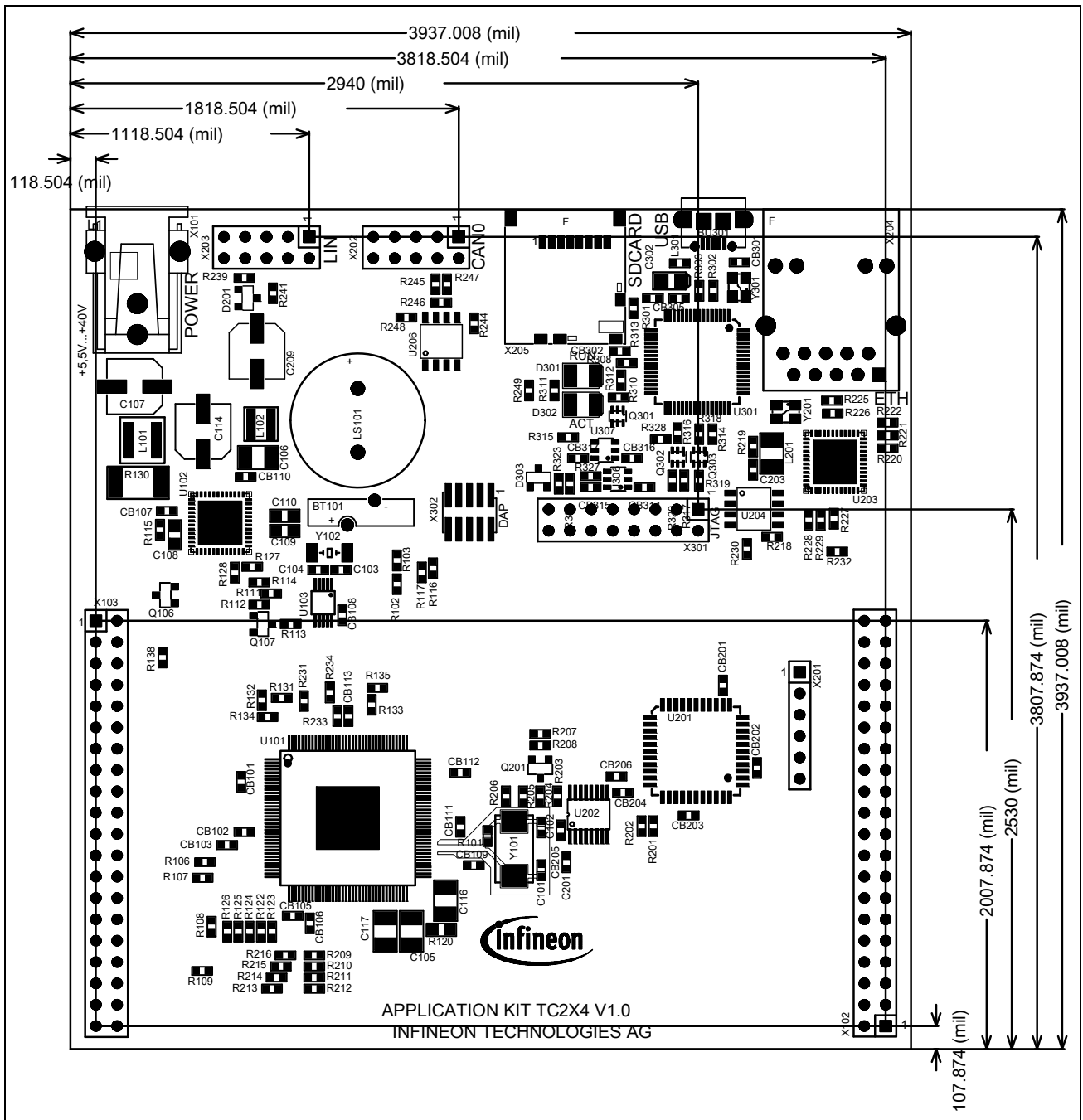

Figure 6-8 Dimensioning (mil)

## Keyword Index

### A

ACTIV LED 3-5

### B

Beeper 3-5

### C

CAN connector pinout 5-2

Clock 3-4

Clock Signals 4-2

Connector Pin Assignment 5-1

Core current measurement 3-6

crystal 3-4

### D

DAP connector pinout 5-4

Debug Signals 4-2

Debug System 3-6

Dimensioning 6-8

### E

Ethernet 3-6

Ethernet Connector 5-4

### F

Flexray Pinout 5-2

### H

HSCT socket pinout 5-3

### I

Interrupt Signals 4-1

### L

Layout 6-6

LEDs 3-4

LIN 3-6

LIN connector pinout 5-3

### M

manual power on reset 3-1

Micro SD card 3-4

miniWiggler JDS 3-5

Multi Voltage Safety Micro Processor Supply 3-1

MultiCAN 3-5

### O

OCDS connector pinout 5-3

OCDS1 3-6

Other peripherals 3-6

### P

Peripheral Signals 4-2

Power connector pinout 5-2

power on reset 3-1

Power Signals 4-1

power supply 3-1

Power via Micro USB 3-1

Power via supply connector 3-1

### R

Read a display register 3-3

Real Time Clock 3-2

Reset Signals 4-1

RUN LED 3-5

### S

Schematic 6-1

Schematic and Layout 6-1

Serial Connection to PC 3-5

Signal Description 4-1

status LED 3-6

Supply 3-1

### T

Toggle LED's 3-6

Touch controller 3-4

## **U**

USB Connector 3-5

USB connector pinout 5-2

## **W**

Write a display register 3-3

## **X**

XGA Display 3-2

[www.infineon.com](http://www.infineon.com)

Published by Infineon Technologies AG