

# NPI-19-I<sup>2</sup>C evaluation Kit (V1.0) User Guide

## Description

NPI-19-I<sup>2</sup>C Nova Sensor evaluation kit was designed to allow quick evaluation of the performance of I<sup>2</sup>C pressure sensor for customer applications. Graphic user interface is available to collect sensor data either by selecting OLED display or USB streaming serial data. Full details about sensor output characteristics and specifications are described in NPI-19 Series datasheet which is available from Amphenol Advanced Sensor, Inc, and should be consulted in conjunction with this user guide when using this evaluation kit.

## Features

- I<sup>2</sup>C calibrated pressure and temperature data display on OLED screen.
- Overvoltage and reverse protection up to +28V and -28V.
- Overvoltage and undervoltage trip at 5.8V and 2.85V.
- UART interfaced serial data logging.

## Application

- Wide supply voltage test capability ranging from 2.9V to 5.5V (Typ. 3.3V) through external power supply.
- Plug and play NPI-19 I<sup>2</sup>C sensor evaluation and proof of concept testing.
- Quick and easy NPI-19 I<sup>2</sup>C sensor demonstration.
- Sensor design verification testing.

# PCB Schematic

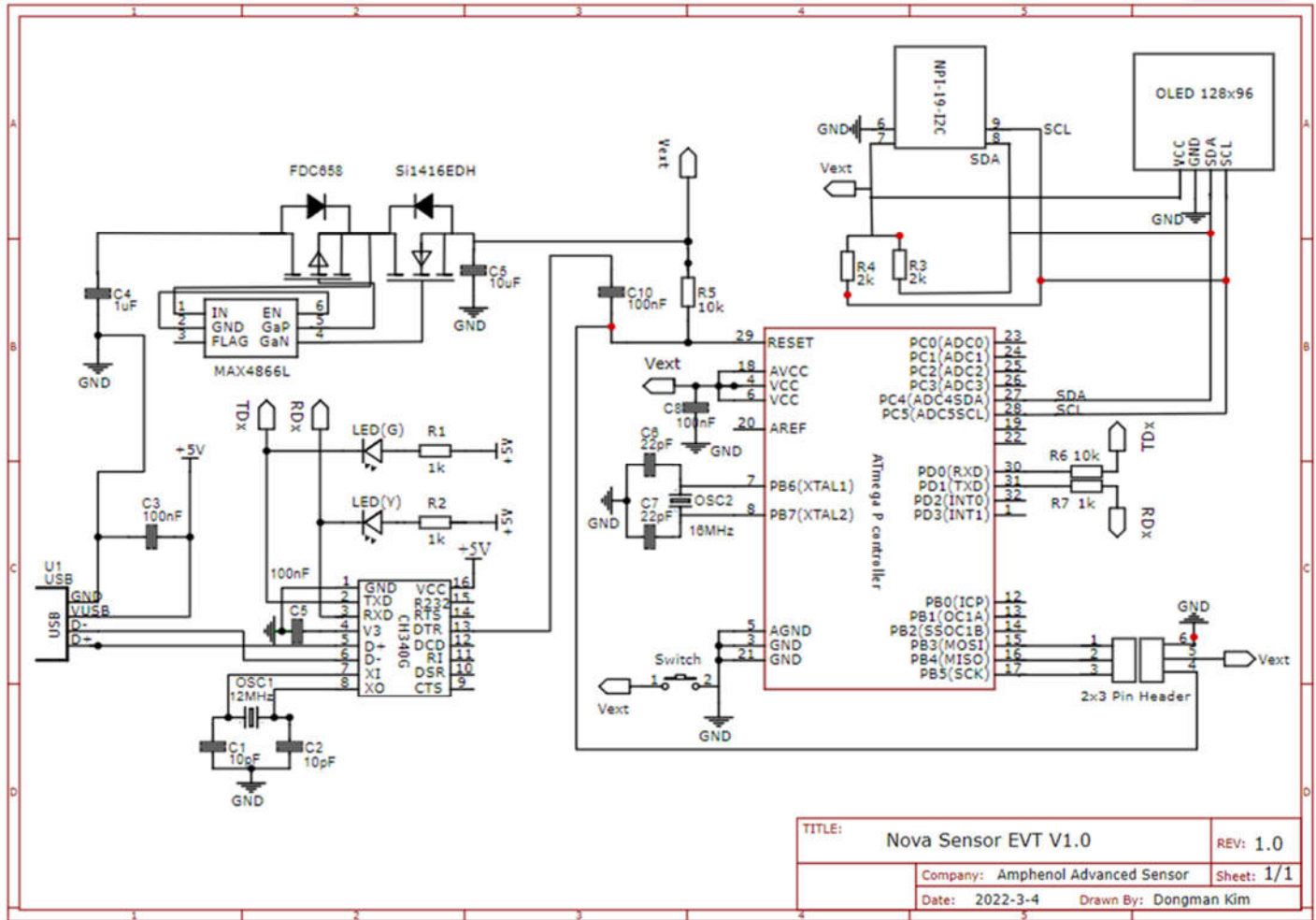

TITLE: Nova Sensor EVT V1.0		REV: 1.0
Company: Amphenol Advanced Sensor		Sheet: 1/1
Date: 2022-3-4	Drawn By: Dongman Kim	

## Step by Step Operating Instructions

1. Connect the NPI-19-I<sup>2</sup>C unit as per pin outline below.

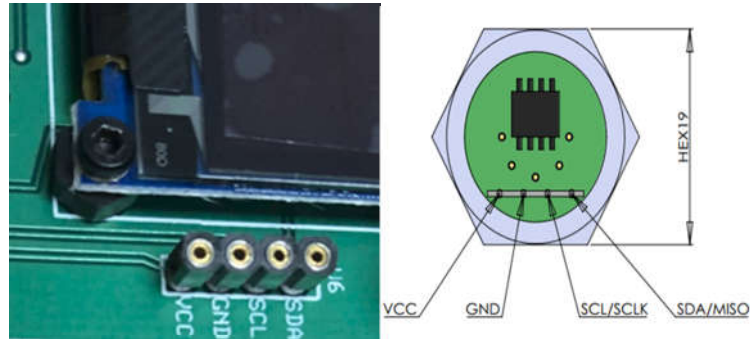

2. Connect Nova Sensor Evaluation board GND and VDD terminals to DC power supply and set power switch to ON position (~3-10mV voltage drop @Vin=3.3V expected).

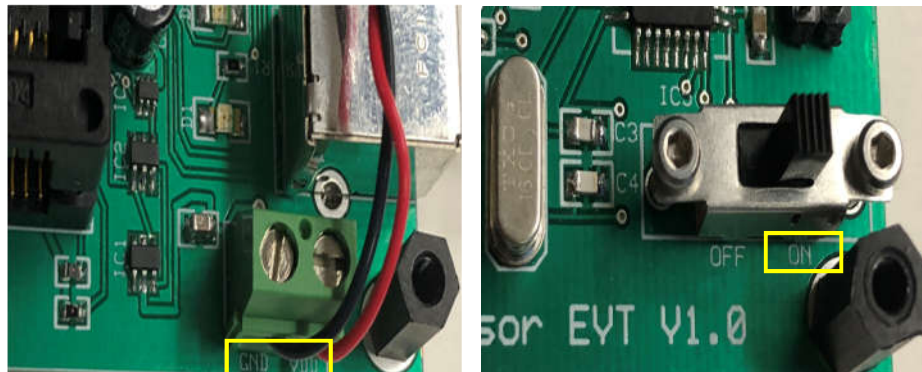

3. USB to serial converter driver compatible with user's window OS in PC will be automatically installed when USB cable is connected to PC.

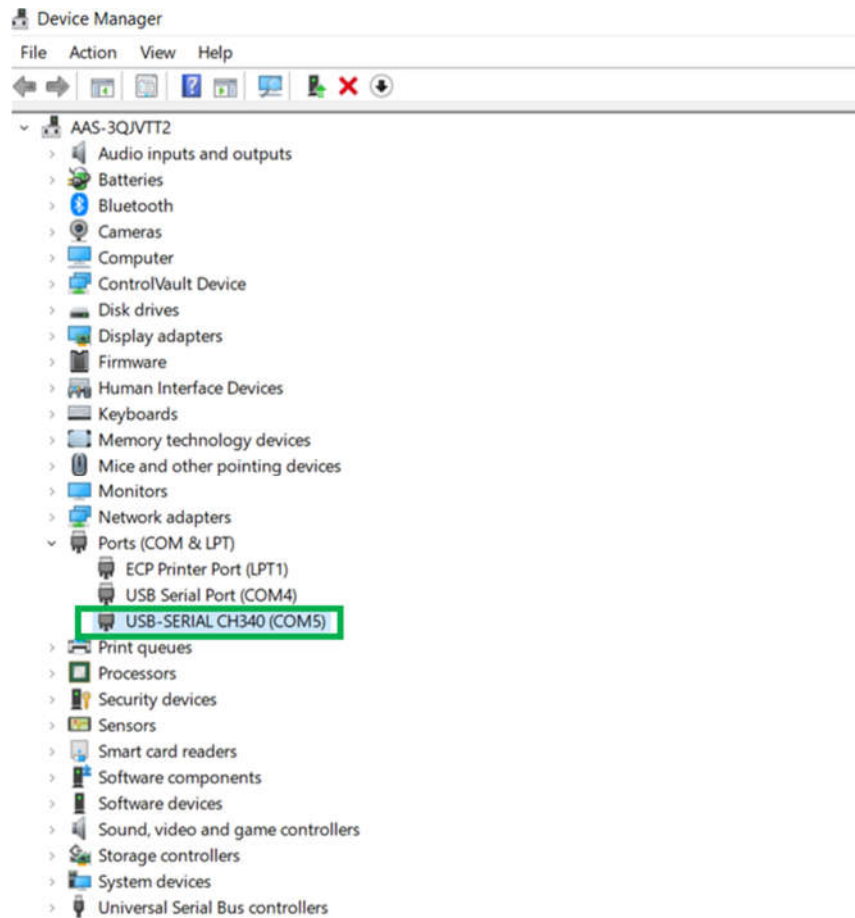

4. Download “NPI19\_EVT\_Installer.exe” to target folder to install MATLAB Run time and NPI19\_EVT executable GUI software.
5. A list of all serial ports on a system will be identified on the NPA19\_EVT GUI and once USB-serial converter port number is selected, USB connection will be established.

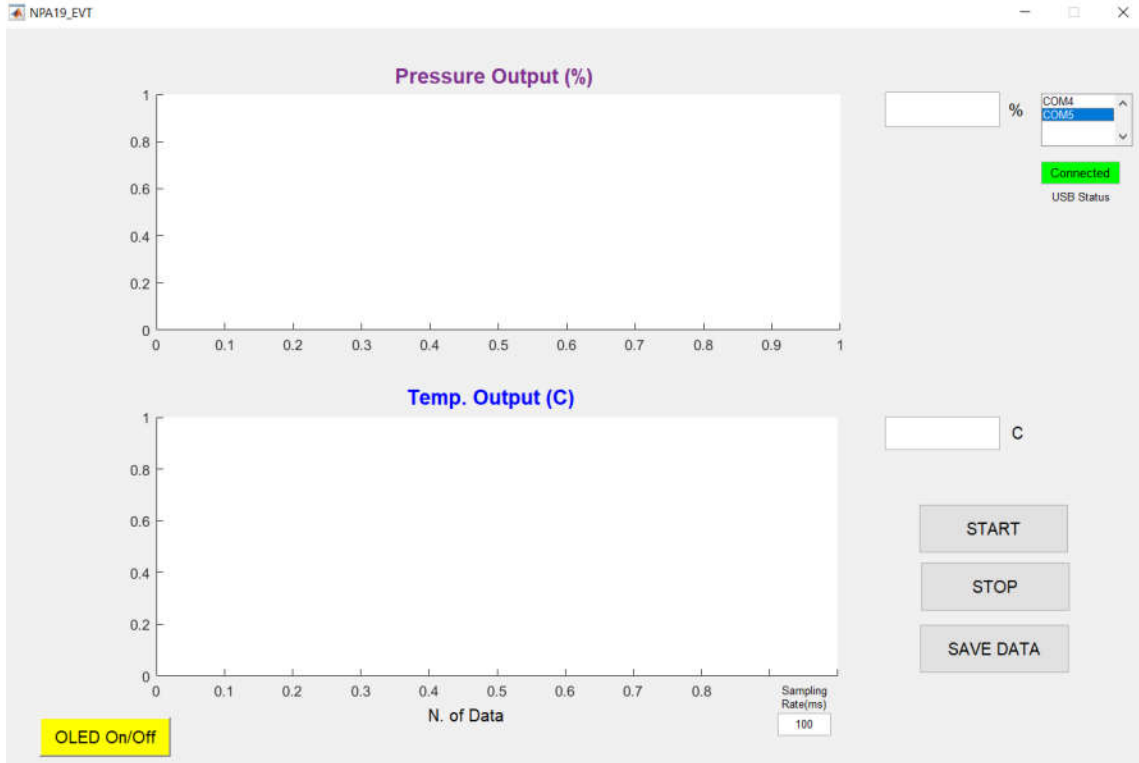

- By default, OLED will display active I2C device's slave address followed by pressure and temperature readings after screen is initialized by applied power ( $V_{in}=3.3V$ ).

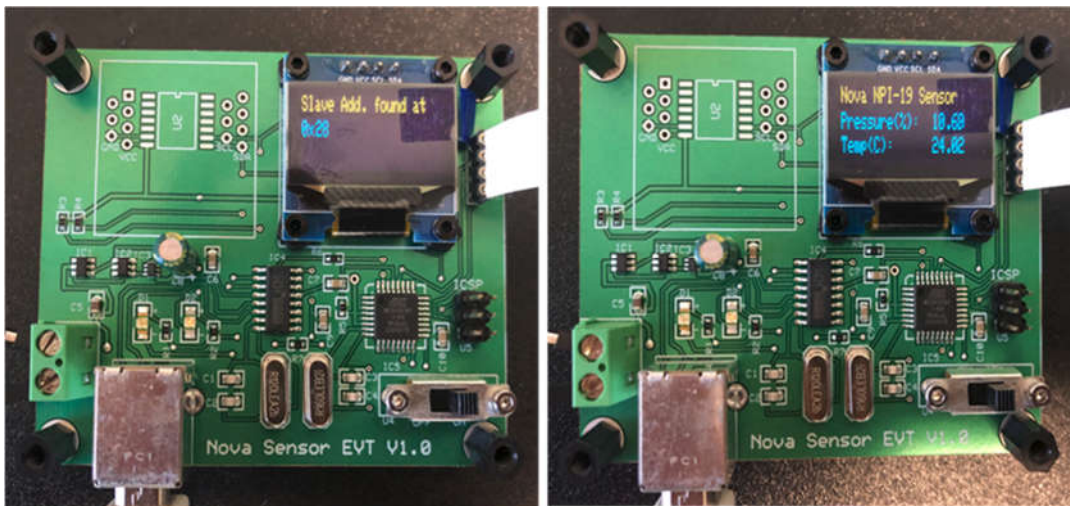

7. OLED screen input on the evaluation board can be toggled ON/OFF by clicking OLED control button on the GUI.
8. The desired sampling rate can be entered to acquire I2C output at fixed data acquisition rate (>100ms recommended) and there is no requirement to configure baud rate, data, and parity bits.

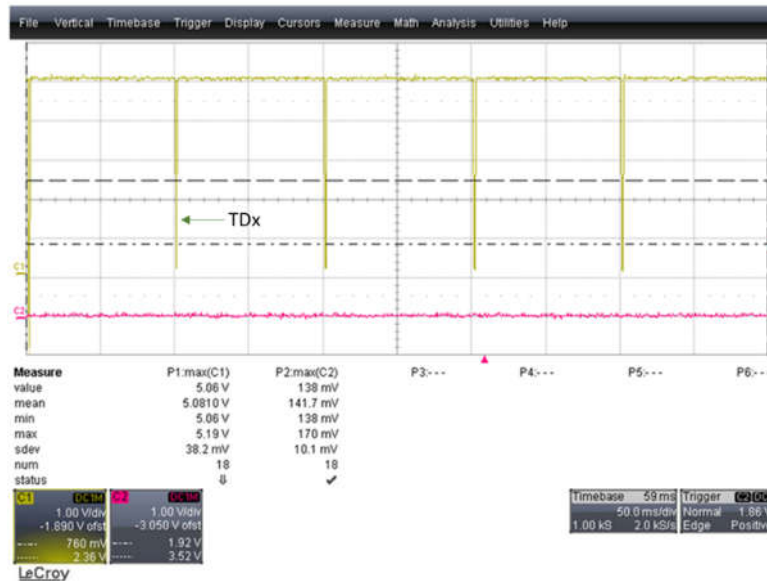

9. In order to initiate serial I2C data collection through USB cable rather than live I2C data monitoring on OLED screen, START button should be clicked on the GUI and I2C pressure and temperature data will be plotted at pre-determined sampling rate on the GUI.

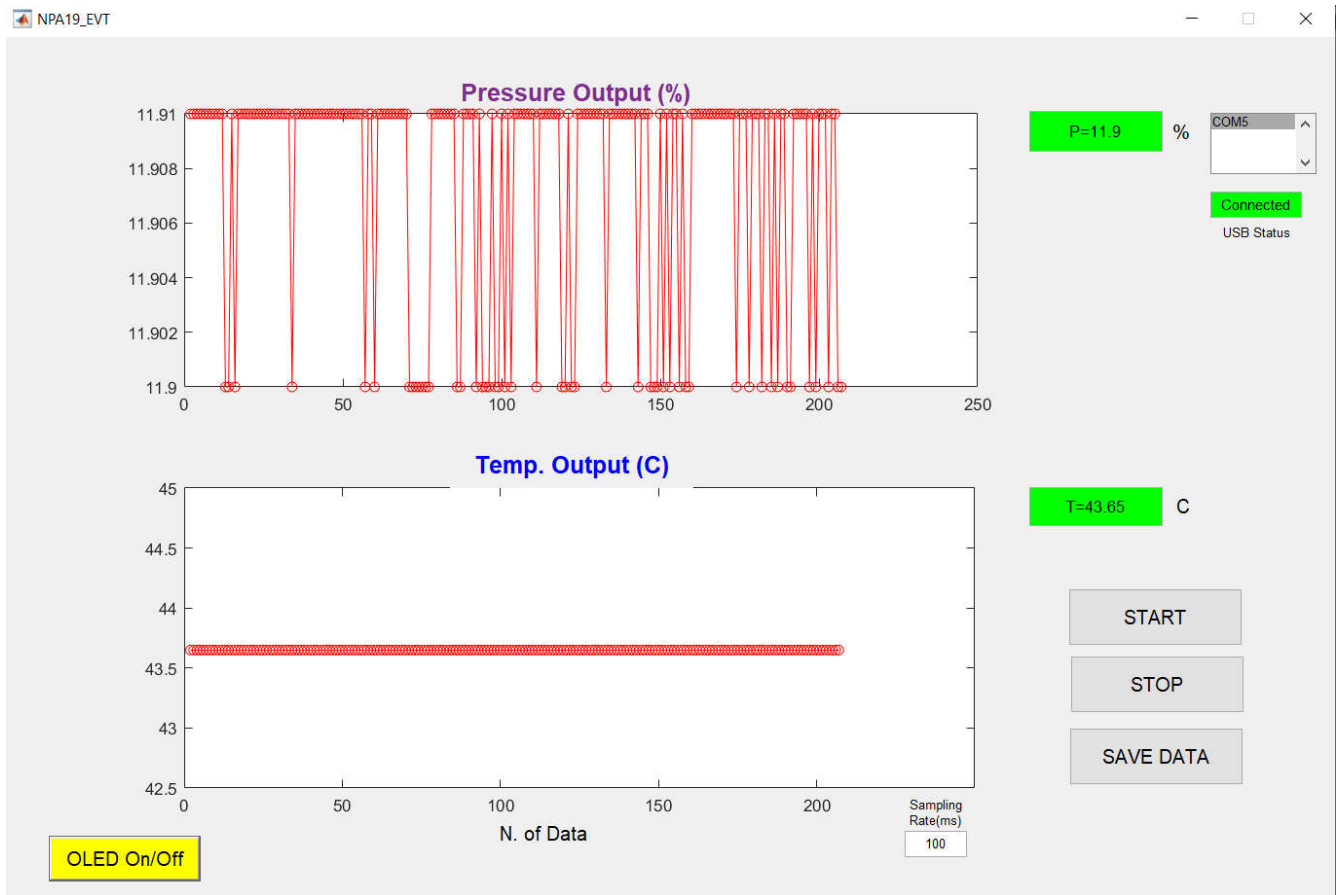

10. The serial data execution will automatically stop I2C data display on OLED screen and I2C data file can be logged onto the same directory as GUI in Comma Separated File (CSV) format.
11. The data file name will be saved with unique current date/time string and status Bit (in DEC), calibrated pressure (in % ADC) and temperature (in C), and sampling rate (ms) will be recorded in Comma Separated File (CSV) format.

I2C\_20211201T151943\_Data.csv - Excel

File Home FMEA Analysis Insert Page Layout Formulas Data Review View Add-ins LOAD TEST Foxit PDF JMP Power

Cut Copy Paste Format Painter Clipboard Font Alignment Number

Calibri 11 Wrap Text Merge & Center General \$ % .00 /0

Conditional Formatting Format as Table

M16

	A	B	C	D	E	F	G	H	I	J	K
1	Status(in DEC)	Pressure(%ADC)	Temperature(C)	Sampling Rate(ms)							
2	0	11.91	43.65	100.0044							
3	0	11.91	43.65	100.0014							
4	0	11.91	43.65	100.0021							
5	0	11.91	43.65	100.0022							
6	0	11.91	43.65	100.0012							
7	0	11.91	43.65	100.0012							
8	0	11.91	43.65	100.0021							
9	0	11.9	43.65	100.0013							
10	0	11.9	43.65	100.0013							
11	0	11.91	43.65	100.0012							
12	0	11.9	43.65	100.0031							
13	0	11.91	43.65	100.0019							
14	0	11.91	43.65	100.0013							
15	0	11.91	43.65	100.0019							
16	0	11.91	43.65	100.0015							
17	0	11.91	43.65	100.0012							
18	0	11.91	43.65	100.0016							
19	0	11.91	43.65	100.0015							
20	0	11.91	43.65	100.0015							
21	0	11.91	43.65	100.0013							
22	0	11.91	43.65	100.0011							
23	0	11.91	43.65	100.0016							
24	0	11.91	43.65	100.0012							
25	0	11.91	43.65	100.002							
26	0	11.91	43.65	100.0012							
27	0	11.91	43.65	100.001							
28	0	11.91	43.65	100.0127							
29	0	11.91	43.65	100.0014							
30	0	11.9	43.65	100.002							

I2C\_20211201T151943\_Data