

REVISIONS				
P	LTN	DESCRIPTION	DATE	APVD
A		RELEASED	15MAY2019	CJV JW
B		REVISED PER ECO-19-011736	06AUG2019	AP JW
C		REVISED PER ECO-20-016913	01DEC2020	TX DZ
E		REVISED PER ECN-22-159726	16JUN2022	TX DZ

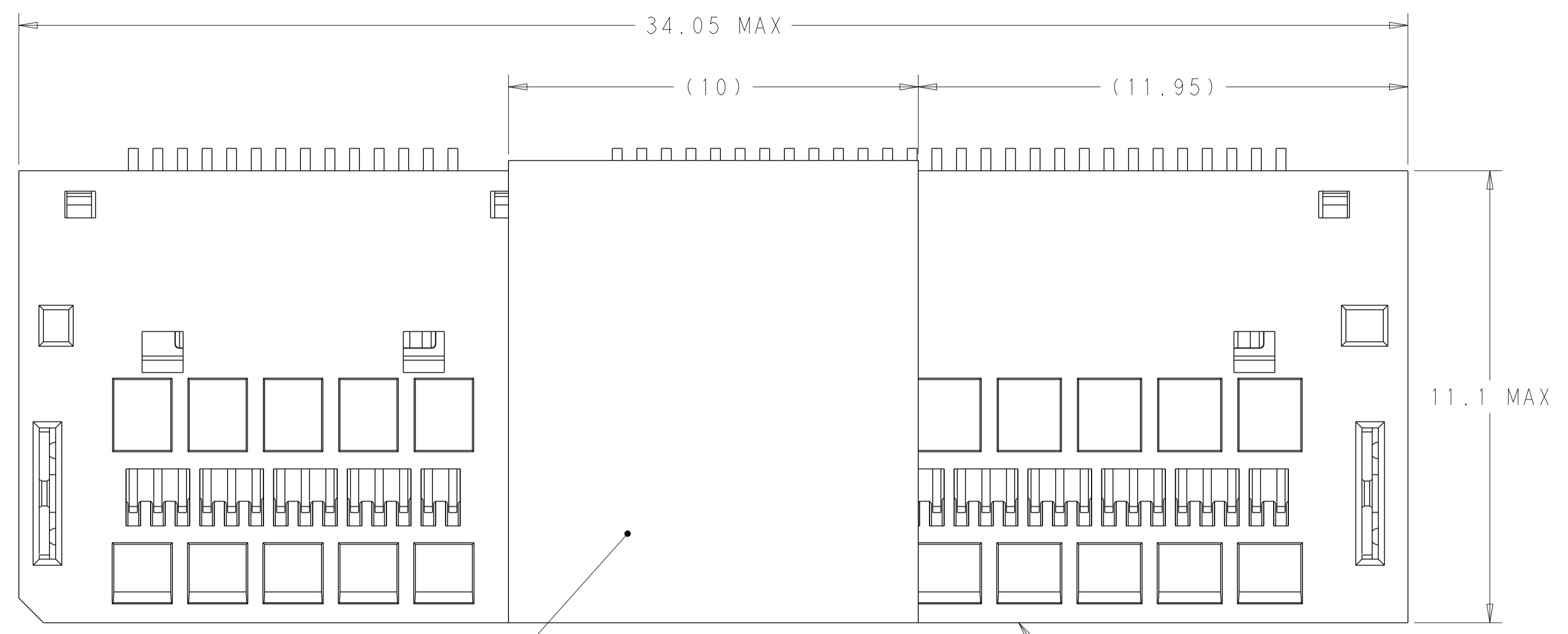

- 1. HOUSING, ORGANIZER, CONTACT OVERMOLDS - LCP, UL94-V0, BLACK. CONTACTS AND HOLD DOWNS - COPPER ALLOY. PICK AND PLACE TAPE - POLYIMIDE FILM.
- 2. CONTACTS - GOLD PLATE ON MATING SURFACES, TIN PLATE ON SOLDER FEET. HOLD DOWNS - TIN PLATE.
- 3. DATUMS AND BASIC DIMENSIONS ESTABLISHED BY CUSTOMER.
- 4. MINIMUM HOST PCB THICKNESS: 1.5.
- 5. SEE MSA SPECIFICATION FOR ADDITIONAL PADDLE CARD LAYOUTS COMPATIBLE WITH THIS RECEPTACLE AND FOR OPTIONAL SPLIT CONTACT PAD LAYOUTS FOR THE PADDLE CARD. SPECIFICATION PINOUT MAY ALSO DESIGNATE PAD SEQUENCE DIFFERENT FROM ILLUSTRATION.
- 6. POSITIONS DESIGNATED AS "SIGNAL" ARE REQUIRED LOCATIONS FOR HIGH SPEED DIFFERENTIAL PAIR SIGNALING. THESE LOCATIONS MAY ALSO BE USED FOR SUPPORTING SIDEBAND SIGNALS OR OTHER UTILITY PURPOSES. POSITIONS DESIGNATED AS "GROUND" ARE REQUIRED WHEN SUPPORTING HIGH SPEED DIFFERENTIAL SIGNALS. THESE LOCATIONS MAY ALSO BE USED FOR SIDEBAND SIGNALS OR OTHER UTILITY PURPOSES.
- 7. COMPONENT AND TRACE KEEP OUT AREA. EACH EDGE 0.15 MIN FROM EDGE OF HOLE.
- 8. TAPE AND REEL PACKAGED FOR PICK AND PLACE SMT PROCESSING, SEE FIGURE 1. POCKET TAPE WIDTH = 56.

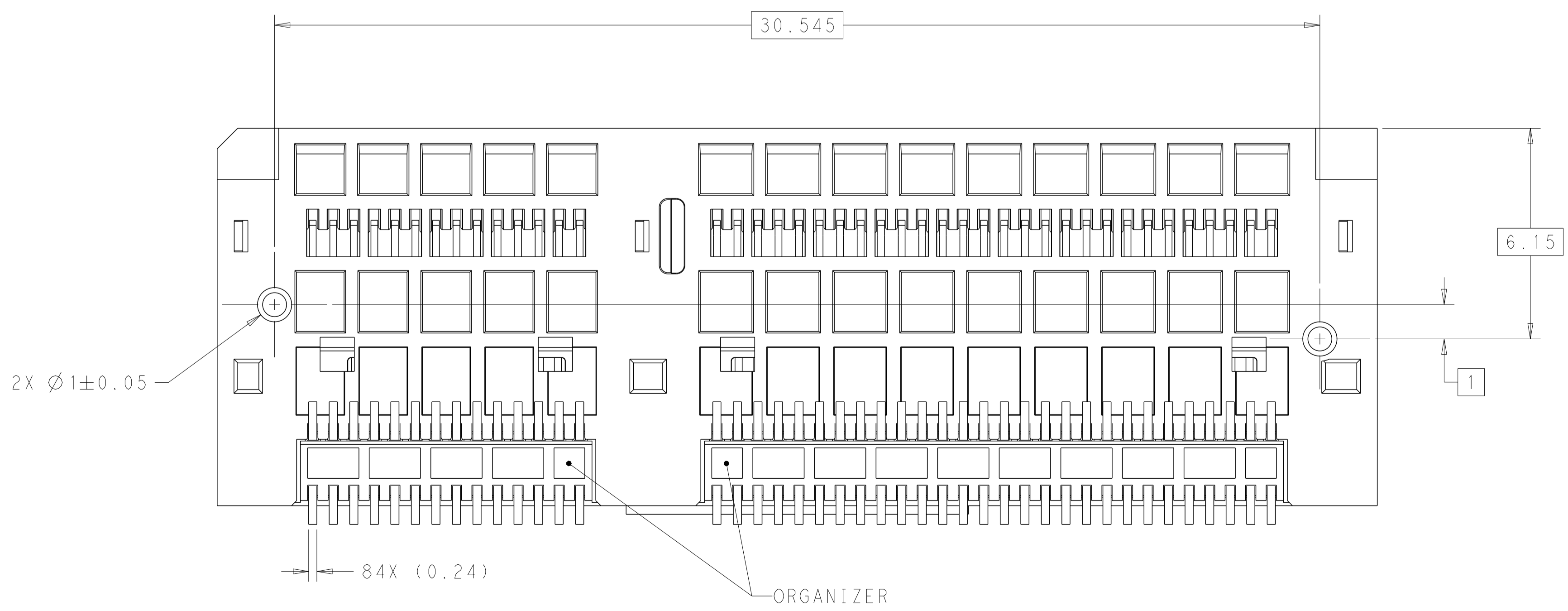
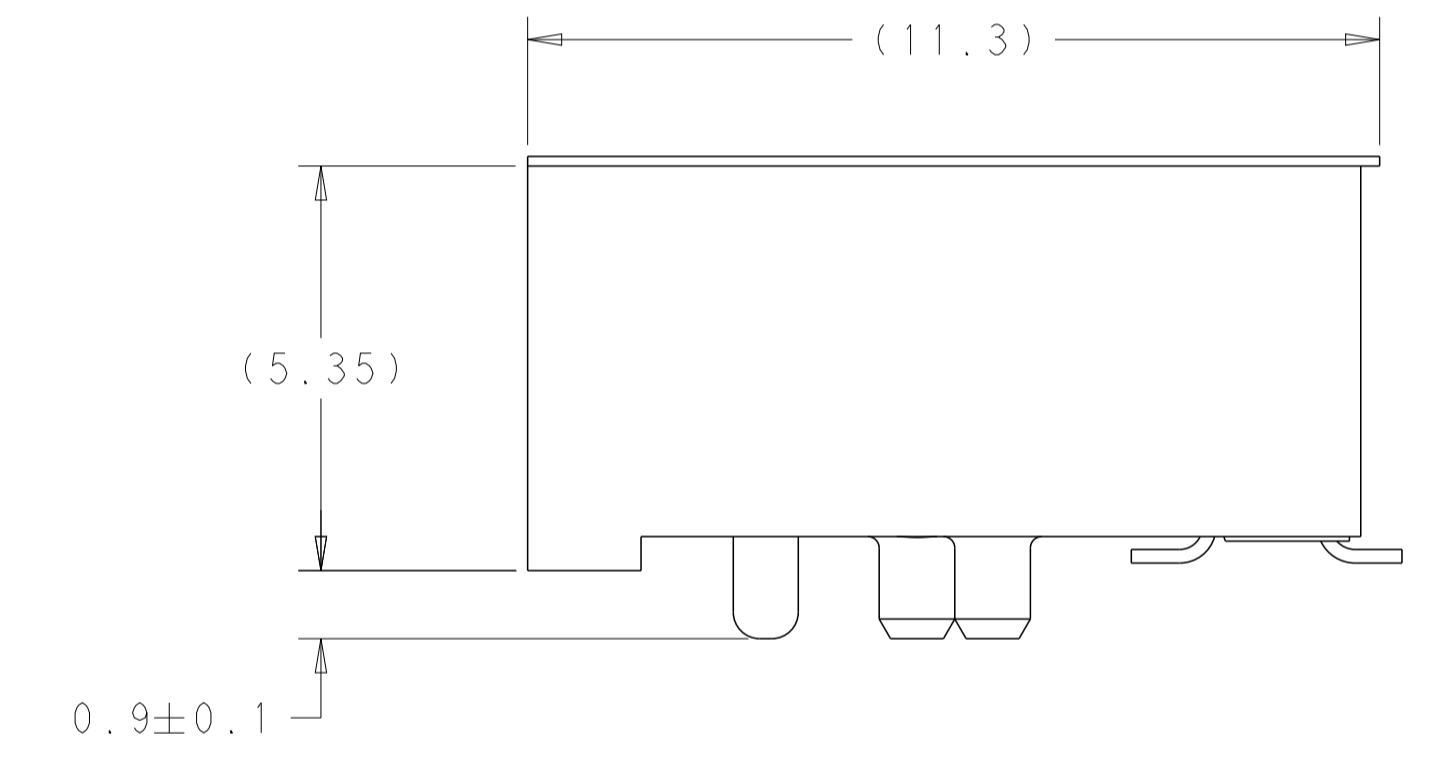
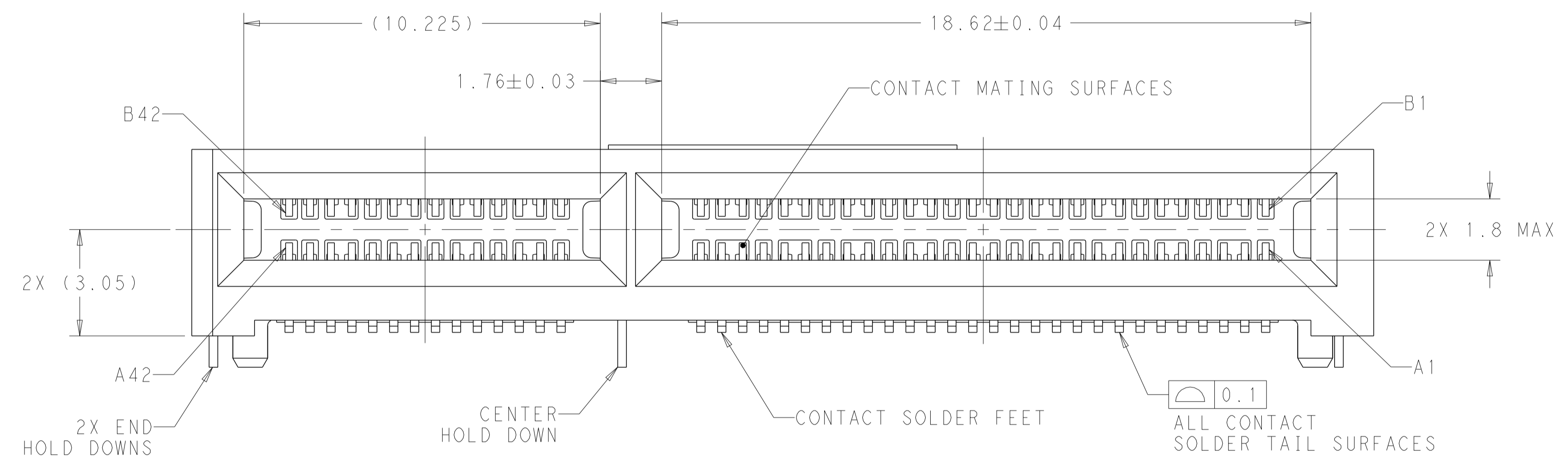

SEE SHEET 5 FOR PART TABLE

THIS DRAWING IS A CONTROLLED DOCUMENT.		OWN: M. SHIRK 22FEB2018	
DIMENSIONS: mm		CHK: D. HARMON 22FEB2018	
TOLERANCES UNLESS OTHERWISE SPECIFIED:		APVD: D. HARMON 22FEB2018	NAME: RECEPTACLE ASSEMBLY, RIGHT ANGLE, 84 POSITION, SILVER 2.0
0 PLC ±	1 PLC ±	PRODUCT SPEC: 108-130021	SIZE: A1
2 PLC ±	3 PLC ±	APPLICATION SPEC: 114-130008	CAGE CODE: -
4 PLC ±	ANGLES ±	WEIGHT: -	DRAWING NO: C=2327671
MATERIAL: △	FINISH: △	CUSTOMER DRAWING	RESTRICTED TO: -
SCALE: 4:1			SHEET 1 OF 5
REV: E			

THIS DRAWING IS UNPUBLISHED. RELEASED FOR PUBLICATION 20
 © COPYRIGHT 20 BY - ALL RIGHTS RESERVED.

REVISIONS				
P	LTN	DESCRIPTION	DATE	APVD
-		SEE SHEET 1	-	-

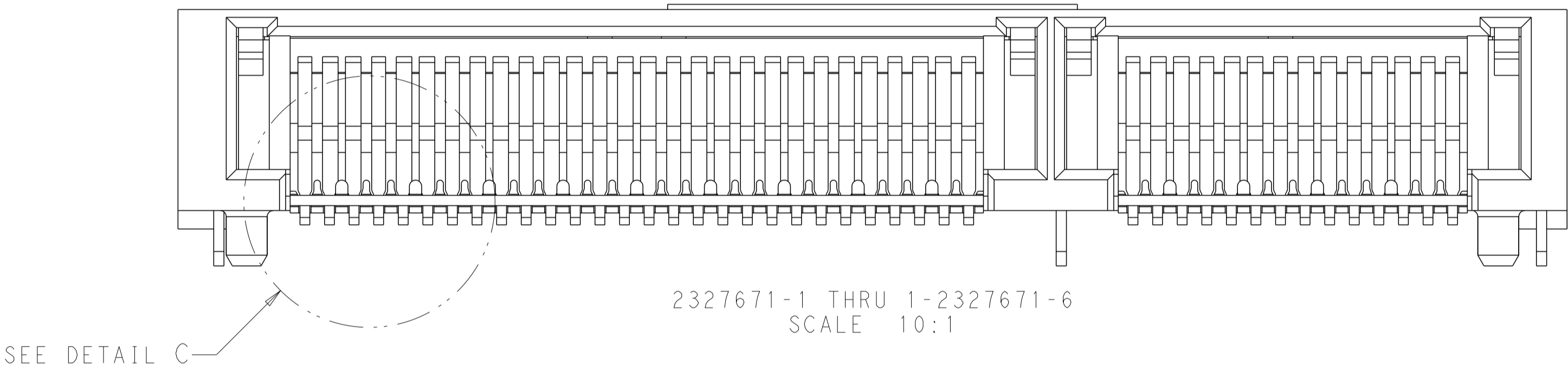
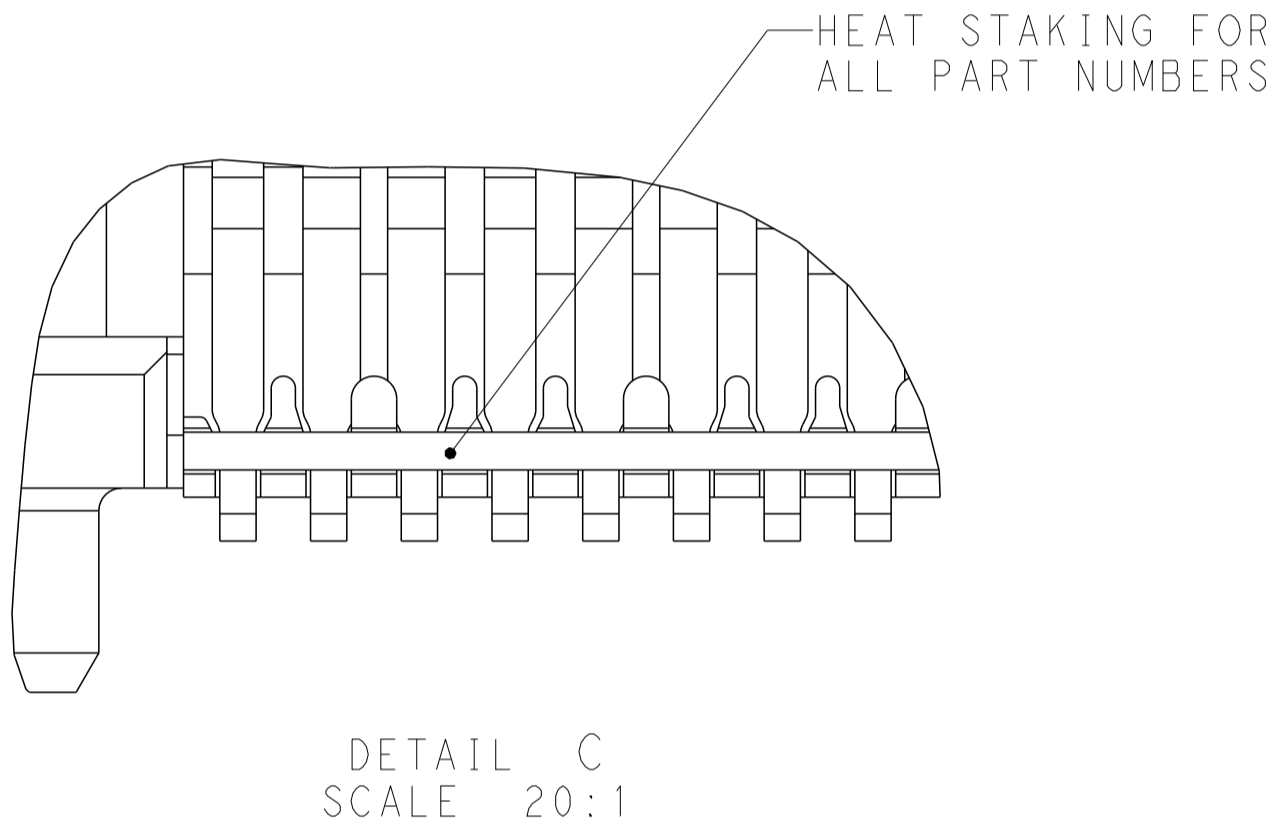

THIS DRAWING IS A CONTROLLED DOCUMENT.		OWN M. SHIRK 22FEB2018	
DIMENSIONS:		CHK D. HARMON 22FEB2018	
mm	TOLERANCES UNLESS OTHERWISE SPECIFIED:	APVD D. HARMON 22FEB2018	NAME RECEPTACLE ASSEMBLY, RIGHT ANGLE, 84 POSITION, SILVER 2.0
0 PLC ±	1 PLC ±	PRODUCT SPEC	SIZE A1
2 PLC ±	3 PLC ±	108-130021	CAGE CODE -
4 PLC ±	ANGLES ±	APPLICATION SPEC	DRAWING NO C=2327671
MATERIAL	FINISH	114-130008	RESTRICTED TO -
CUSTOMER DRAWING		WEIGHT -	SCALE 4:1
			SHEET 2 OF 5
			REV E

REVISIONS				
P.	LTN.	DESCRIPTION	DATE	APPD.
-	-	SEE SHEET 1	-	-

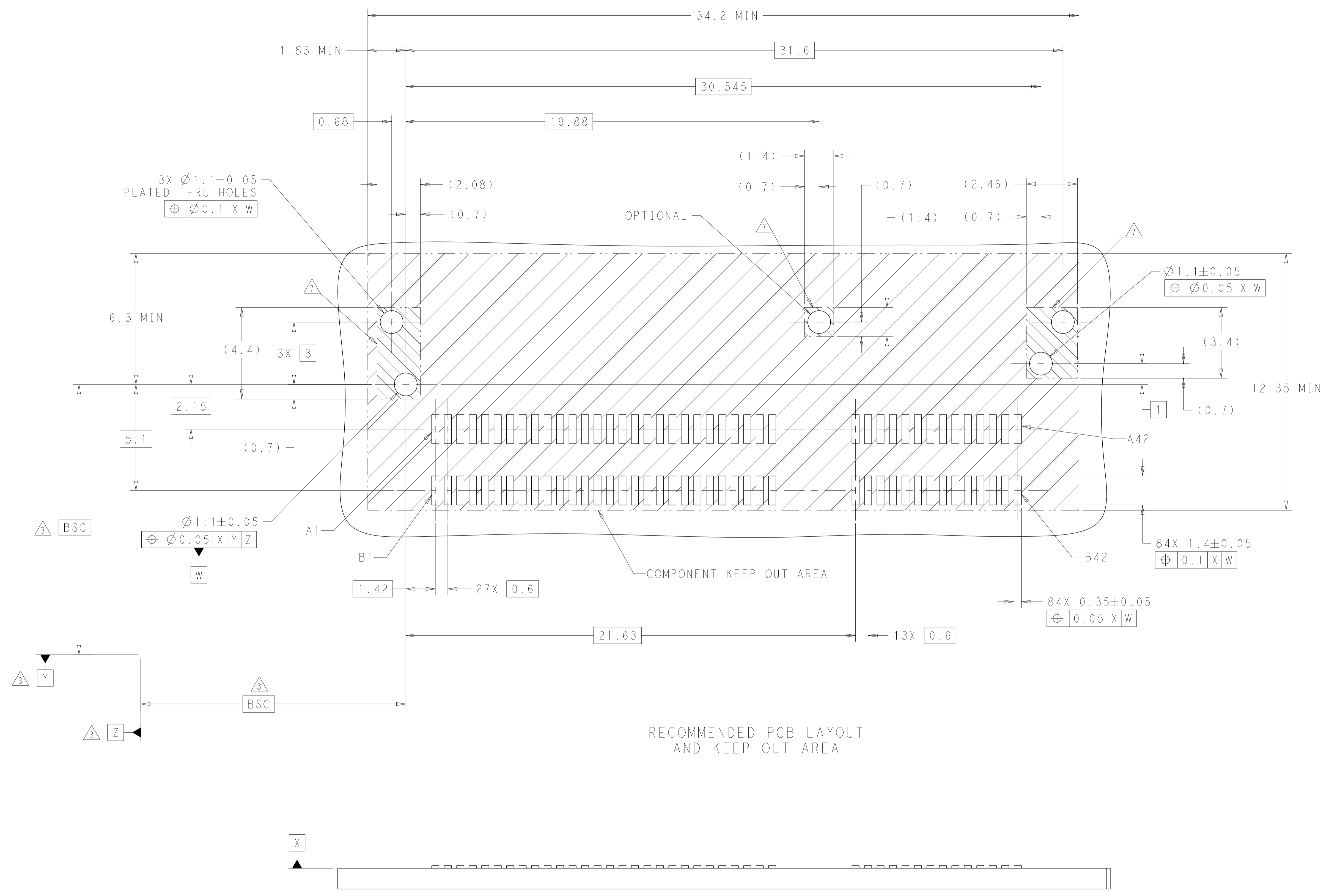

THIS DRAWING IS A CONTROLLED DOCUMENT.		OWN: M. SHIRK 22FEB2018	TE Connectivity
DIMENSIONS: mm		CHK: D. HARMON 22FEB2018	
TOLERANCES UNLESS OTHERWISE SPECIFIED: 0 PLC ± 1 PLC ± 2 PLC ± 3 PLC ± 4 PLC ± ANGLES ° ±		APPD: D. HARMON 22FEB2018	NAME: RECEPTACLE ASSEMBLY, RIGHT ANGLE, 84 POSITION, SILVER 2.0
MATERIAL FINISH		PRODUCT SPEC: 108-130021	APPLICATION SPEC: -
CUSTOMER DRAWING		SIZE: A1	SCALE: 4:1
		WEIGHT: -	SHEET 3 OF 5
		REVISION: C=2327671	REV: E

REVISIONS				
P	LTN	DESCRIPTION	DATE	APVD
-	-	SEE SHEET 1	-	-

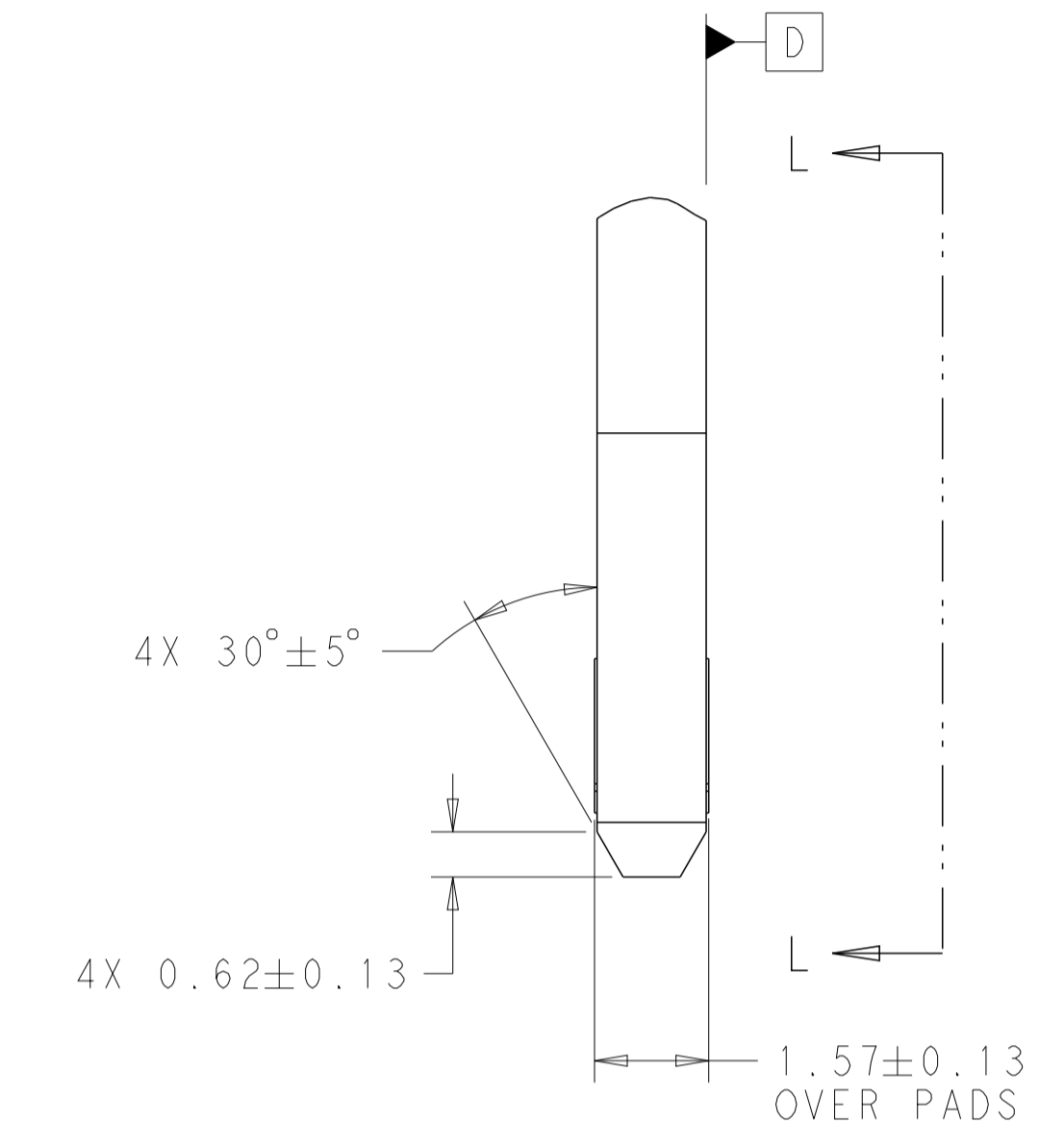
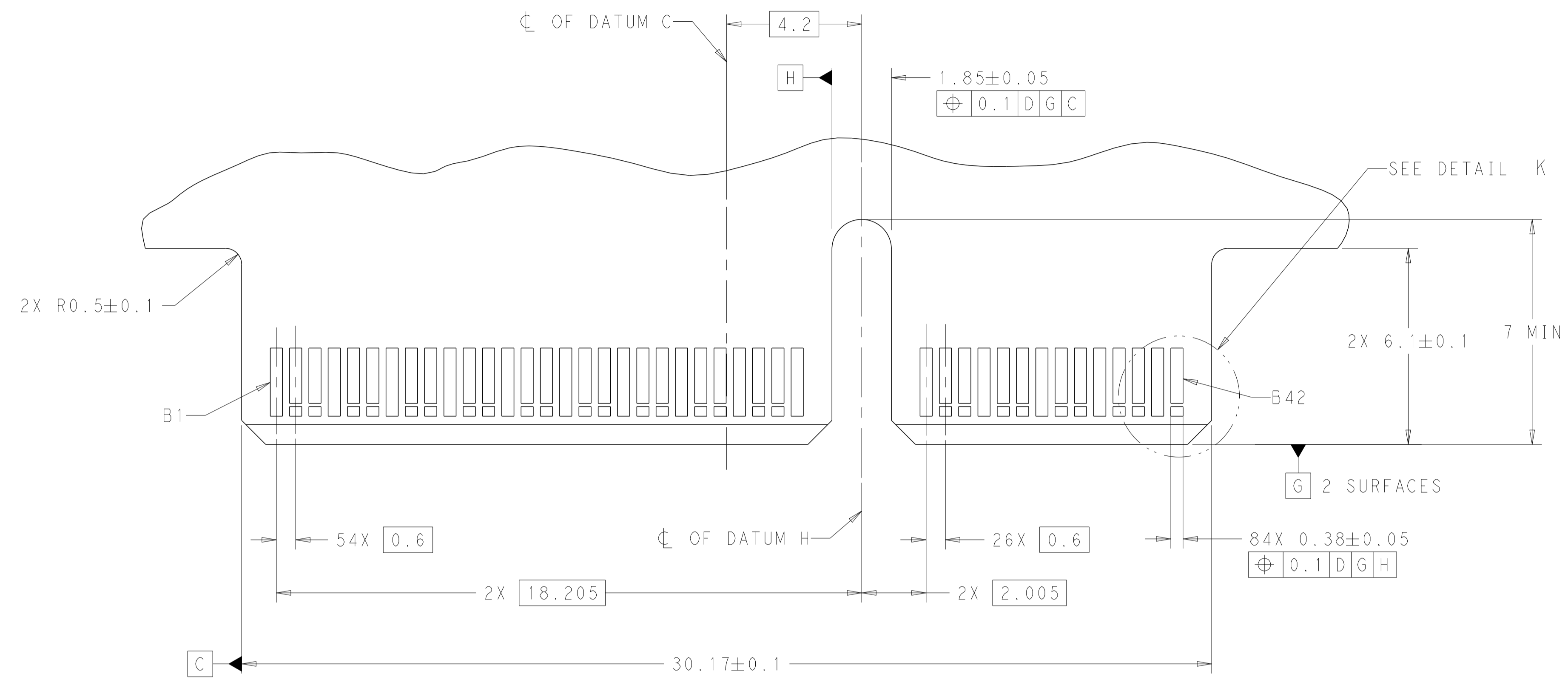

RECOMMENDED PCB OUTLINE DIMENSIONS:
 TOLERANCE VALUES ARE CRITICAL. PLEASE BE SURE TO DESIGNATE
 TOLERANCES TO PCB SUPPLIER TO ENSURE OPTIMIZED FUNCTIONALITY.

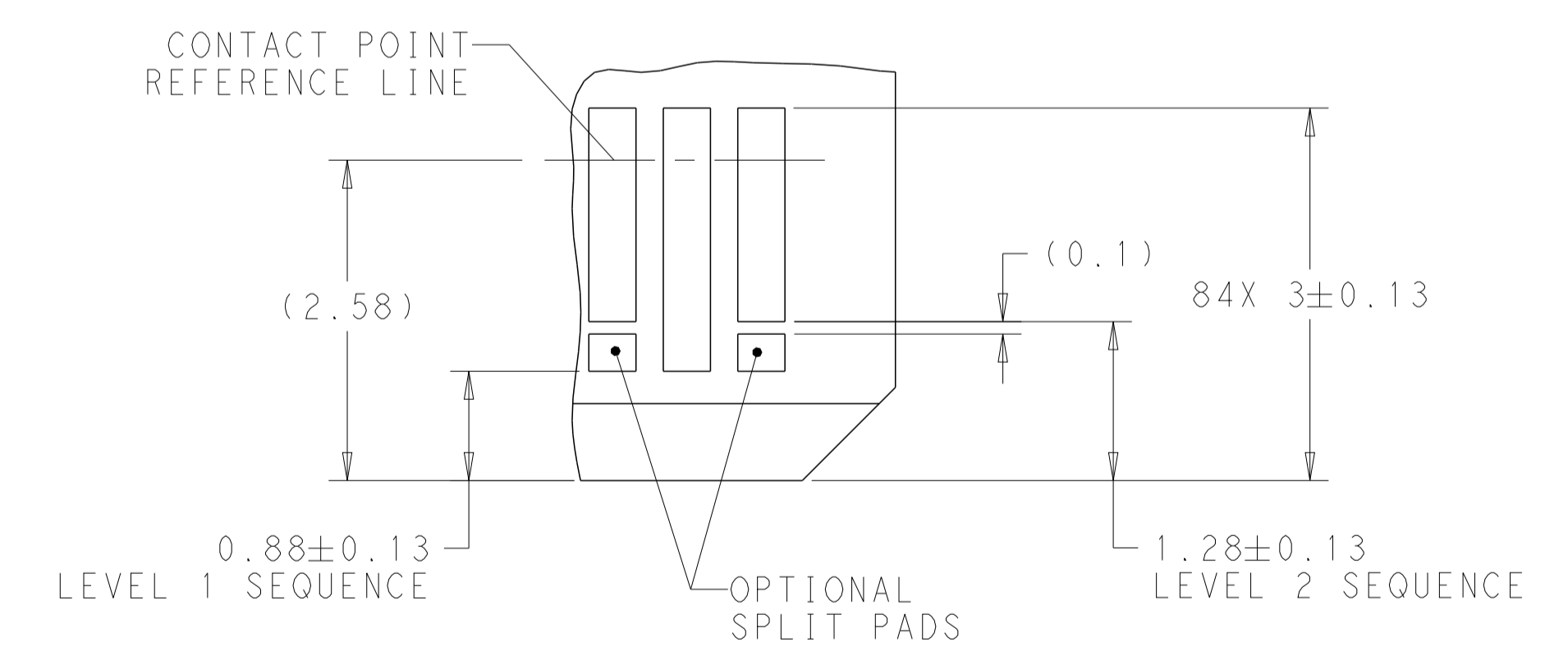

DETAIL K
 SCALE 20:1

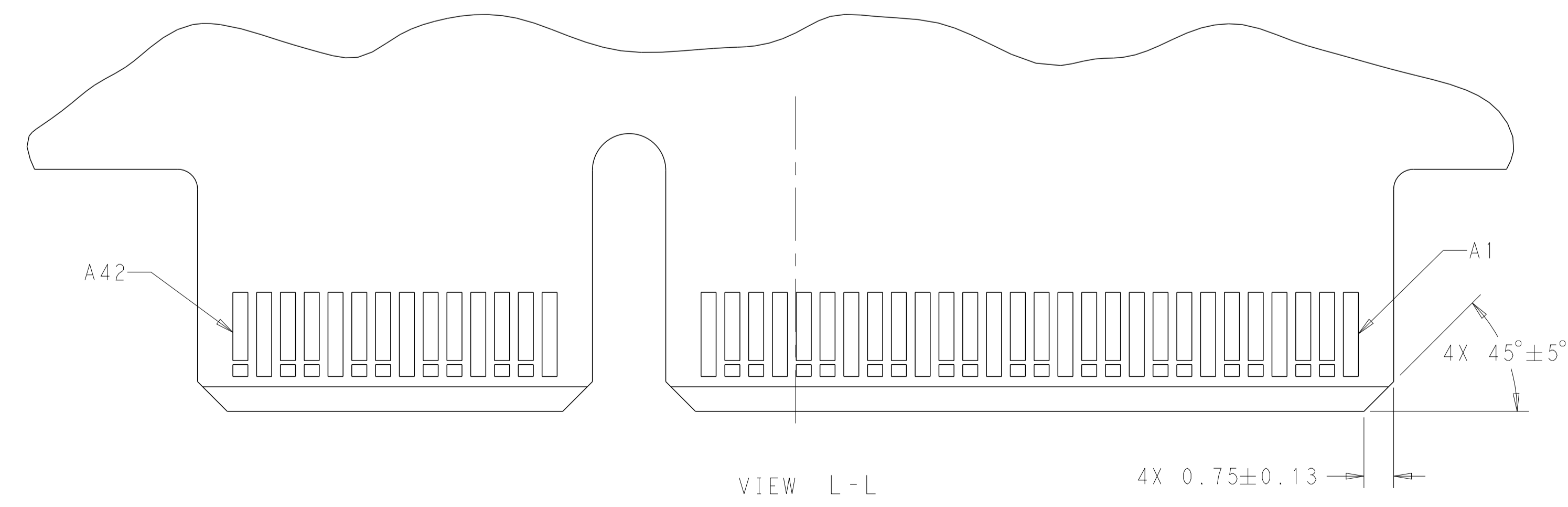

THIS DRAWING IS A CONTROLLED DOCUMENT.		OWN: M. SHIRK 22FEB2018	TE Connectivity
DIMENSIONS: mm		CHK: D. HARMON 22FEB2018	
TOLERANCES UNLESS OTHERWISE SPECIFIED:		APVD: D. HARMON 22FEB2018	NAME: RECEPTACLE ASSEMBLY, RIGHT ANGLE, 84 POSITION, SILVER 2.0
0 PLC	±	PRODUCT SPEC	108-130021
1 PLC	±	APPLICATION SPEC	114-130008
2 PLC	±	WEIGHT	-
3 PLC	±	SIZE	A1
4 PLC	±	CAGE CODE	-
ANGLES	±	DRAWING NO	C=2327671
FINISH	±	RESTRICTED TO	-
MATERIAL	±	CUSTOMER DRAWING	SCALE 4:1 SHEET 4 OF 5 REV E

TABLE 1: CONNECTOR CONTACT IDENTIFICATION \triangle \triangle \triangle

CONTACT NUMBER	SIDE A	SIDE B
1	GROUND	GROUND
2	SIGNAL	SIGNAL
3	SIGNAL	SIGNAL
4	GROUND	GROUND
5	SIGNAL	SIGNAL
6	SIGNAL	SIGNAL
7	GROUND	GROUND
8	SIGNAL	SIGNAL
9	SIGNAL	SIGNAL
10	GROUND	GROUND
11	SIGNAL	SIGNAL
12	SIGNAL	SIGNAL
13	GROUND	GROUND
14	SIGNAL	SIGNAL
15	SIGNAL	SIGNAL
16	GROUND	GROUND
17	SIGNAL	SIGNAL
18	SIGNAL	SIGNAL
19	GROUND	GROUND
20	SIGNAL	SIGNAL
21	SIGNAL	SIGNAL
22	GROUND	GROUND
23	SIGNAL	SIGNAL
24	SIGNAL	SIGNAL
25	GROUND	GROUND
26	SIGNAL	SIGNAL
27	SIGNAL	SIGNAL
28	GROUND	GROUND
29	GROUND	GROUND
30	SIGNAL	SIGNAL
31	SIGNAL	SIGNAL
32	GROUND	GROUND
33	SIGNAL	SIGNAL
34	SIGNAL	SIGNAL
35	GROUND	GROUND
36	SIGNAL	SIGNAL
37	SIGNAL	SIGNAL
38	GROUND	GROUND
39	SIGNAL	SIGNAL
40	SIGNAL	SIGNAL
41	GROUND	GROUND
42	GROUND	GROUND

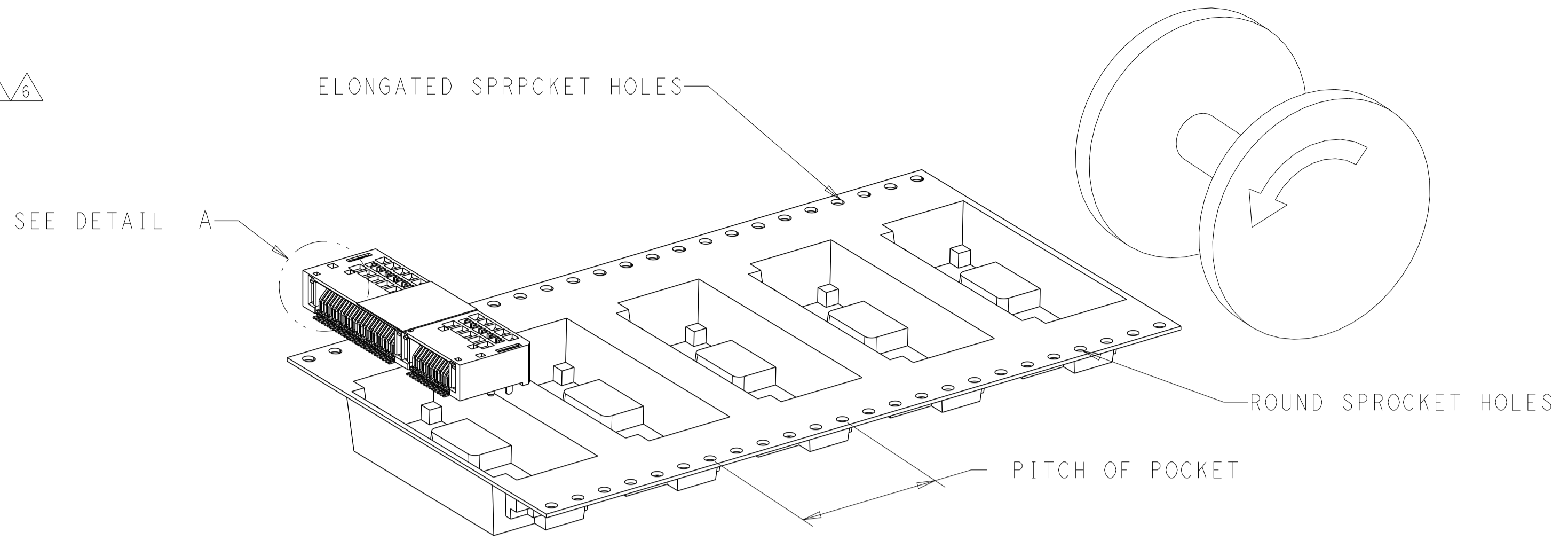

FIGURE 1 \triangle \triangle \triangle
 DIRECTION OFF TOP OF REEL
 FOR USER UNREELING
 SHOWN AS 2327671-1 THRU 2327671-6, 2327671-8
 SCALE 2:1

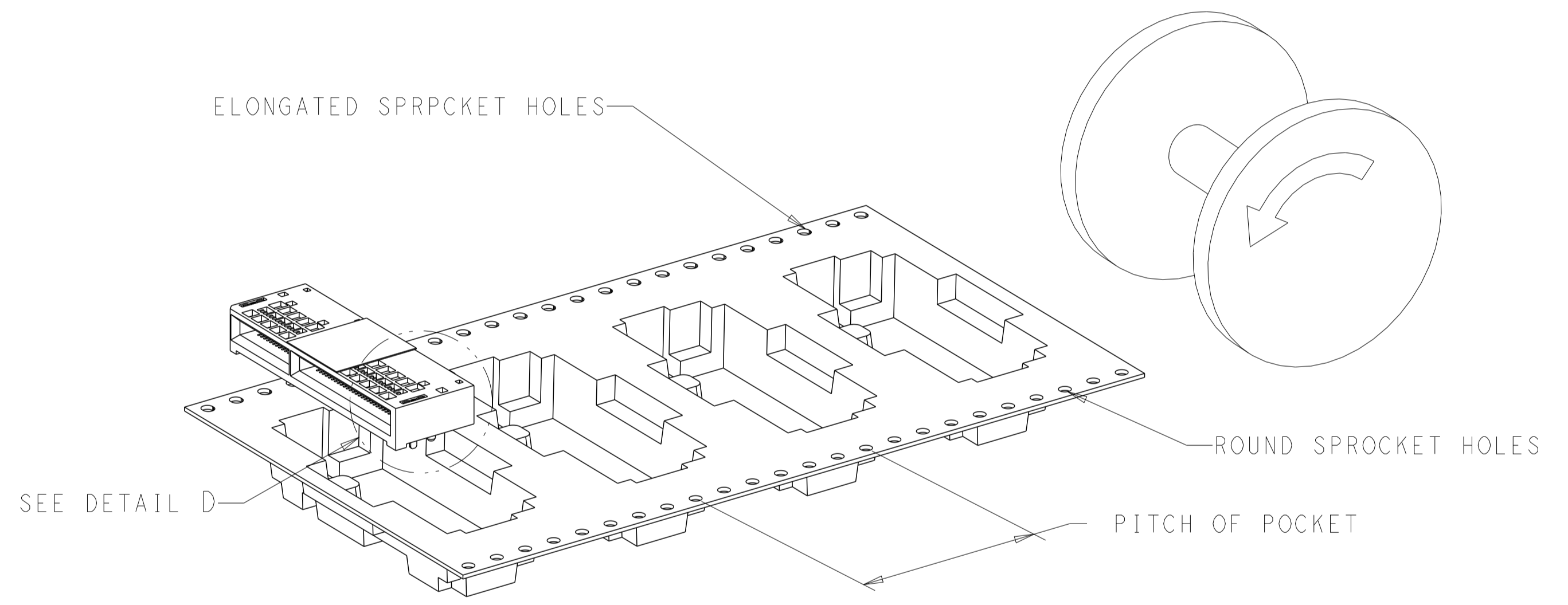
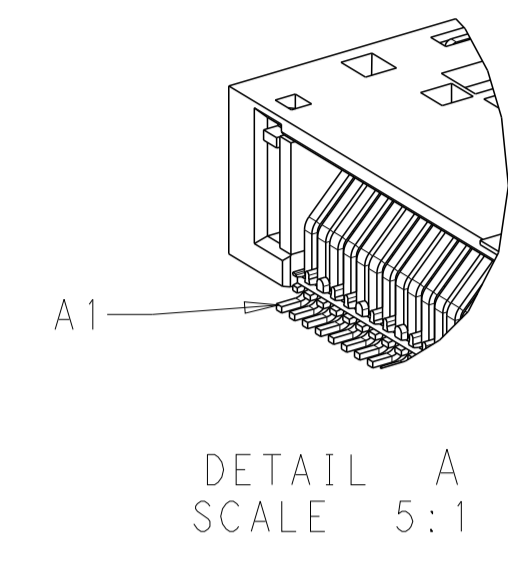
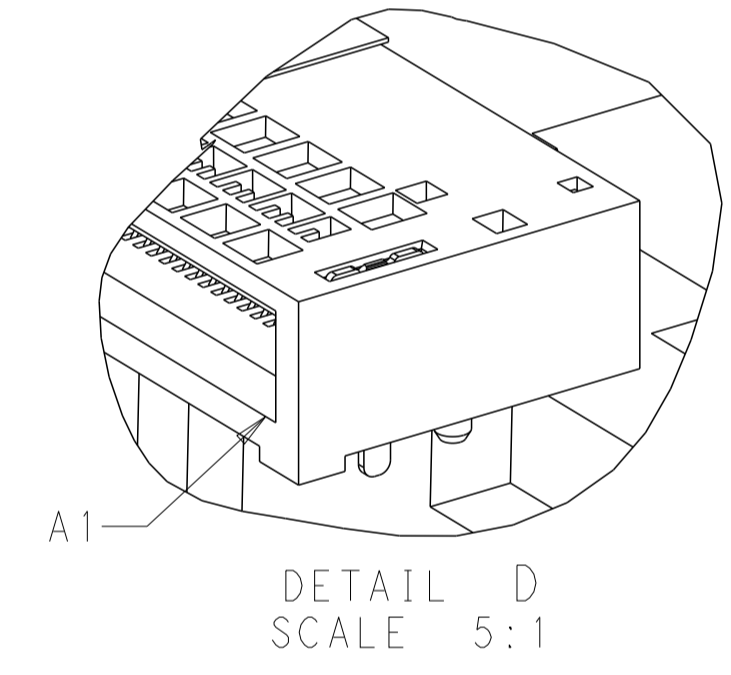

FIGURE 2 \triangle \triangle \triangle
 DIRECTION OFF TOP OF REEL
 FOR USER UNREELING
 SHOWN AS 1-2327671-1 THRU 1-2327671-6
 SCALE 2:1



ENDS	PLATING	POCKET TAPE PITCH	REEL QUANTITY	PICK AND PLACE TAPE	MATING CYCLES	PART NUMBER
ENDS	0.76 μ m Au	24	400	NO	200	1-2327671-6
ENDS	0.38 μ m Au				100	1-2327671-5
ENDS	FLASH Au/PdNi	24	400	NO	50	1-2327671-4
ALL	0.76 μ m Au				200	1-2327671-3
ALL	0.38 μ m Au	20	500	YES	100	1-2327671-2
ALL	FLASH Au/PdNi				50	1-2327671-1
ALL	0.76 μ m Au	20	500	YES	200	2327671-8
ENDS	0.76 μ m Au				200	2327671-6
ENDS	0.38 μ m Au	20	500	YES	100	2327671-5
ENDS	FLASH Au/PdNi				50	2327671-4
ALL	0.76 μ m Au	20	500	YES	200	2327671-3
ALL	0.38 μ m Au				100	2327671-2
ALL	FLASH Au/PdNi	20	500	YES	50	2327671-1
HOLD DOWNS	PLATING				POCKET TAPE PITCH	REEL QUANTITY

THIS DRAWING IS A CONTROLLED DOCUMENT.

APVD: D. HARMON 22FEB2018
 CHK: D. HARMON 22FEB2018
 DWN: M. SHIRK 22FEB2018

STE TE Connectivity

NAME: RECEPTACLE ASSEMBLY, RIGHT ANGLE, 84 POSITION, SILVER 2.0

PRODUCT SPEC: 108-130021
 APPLICATION SPEC: 114-130008

SIZE: A1 CAGE CODE: - DRAWING NO: C=2327671

MATERIAL: FINISH: WEIGHT: CUSTOMER DRAWING

SCALE: 4:1 SHEET 5 OF 5 REV E

REVISIONS				
P.	LTN.	DESCRIPTION	DATE	APVD.
-	-	SEE SHEET 1	-	-