

TOP VIEW

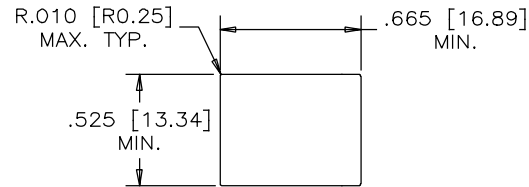

RECOMMENDED PANEL CUTOUT

REVISIONS				
SYM	ZONE	ECN, ERN NO.	DATE	APPRD.
B		UPDATE DRAWING	MAR 12.15	LC
C		CORRECT DIMENSION	JAN 18.16	LC

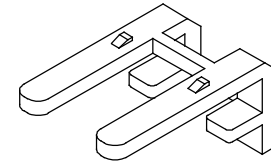

LIGHT PIPE: RJSSE-2485-01

RJSSE-2485-01 MUST BE ORDERED SEPARATELY  
RJSSE-2485-01 MUST BE PACKED SEPARATELY

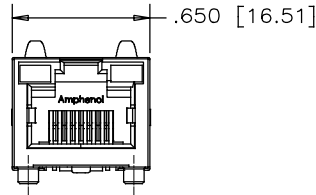

FRONT VIEW

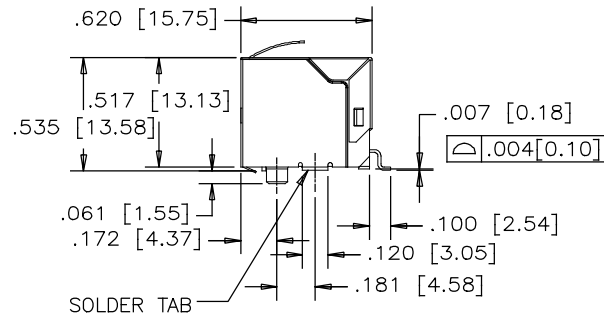

SIDE VIEW

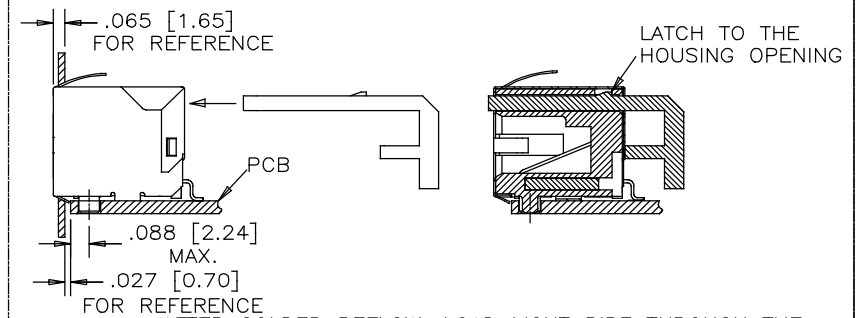

AFTER SOLDER REFLOW, LOAD LIGHT PIPE THROUGH THE CONNECTOR REAR ACCESS IN THE DIRECTION AS SHOWN

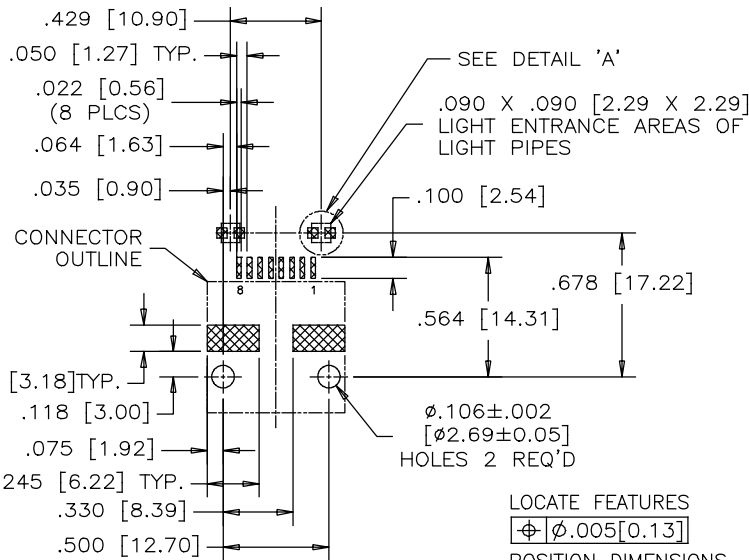

RECOMMENDED P.C.B. LAYOUT  
(COMPONENT SIDE OF BOARD)

LOCATE FEATURES  
POSITION DIMENSIONS  
ARE BASIC

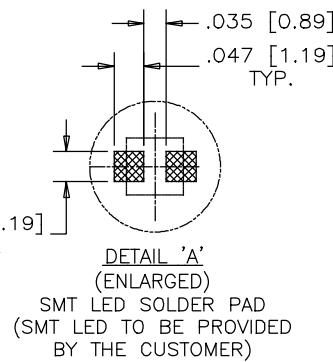

**MATERIALS:**  
PLASTIC HOUSING: ENGINEERING THERMOPLASTIC  
FLAMMABILITY RATING UL 94V-0

**CONTACTS:**  
PHOSPHOR BRONZE  
PLATING: 20 m" [0.51 MICRONS]  
MIN. GOLD ON MATING SURFACES.  
50 m" [1.27 MICRONS]  
MIN. NICKEL UNDERPLATE. TAILS.  
100 m" [2.54 MICRONS]  
MIN. MATTE TIN ON CONTACT

**SHIELD:**  
COPPER ALLOY  
PLATING: NICKEL



PART NUMBER: RJSSE-5382-01T

MATERIAL	DRAWN MT.chen	DATE Feb 27.09	Amphenol Canada Corp.	
	DESIGNED L.C	Feb 27.09		
FINISH	CHECKED		TITLE SINGLE PORT, SURFACE MOUNT RJ45 8 POSITION, 8 CONTACTS, SHIELDED WITHOUT LIGHT PIPE, TAPE & REEL PACKAGING	
	I. E. APPRD.			
	Q. A. APPRD.		DWG C	DRAWING NO. P-RJSSE-5382-01T
	DWG. APPRD.		REF.	REV. C
	ENG. REL. NO.		DIMENSIONS ARE IN INCHES [mm] CODE ID. NO. 03554	
			SCALE 2:1	WT. _____ SURF. _____ SHEET 1 of 2

THIS DOCUMENT CONTAINS PROPRIETARY INFORMATION AND SUCH INFORMATION MAY NOT BE DISCLOSED TO OTHERS FOR ANY PURPOSE OR USED FOR MANUFACTURING PURPOSES WITHOUT WRITTEN PERMISSION FROM AMPHENOL CANADA CORP.

REVISIONS				
SYM	ZONE	ECN, ERN NO.	DATE	APPRD.
B		PROPOSAL	MAR 12.15	LC
C		CORRECT DIMENSION	JAN 18.16	LC

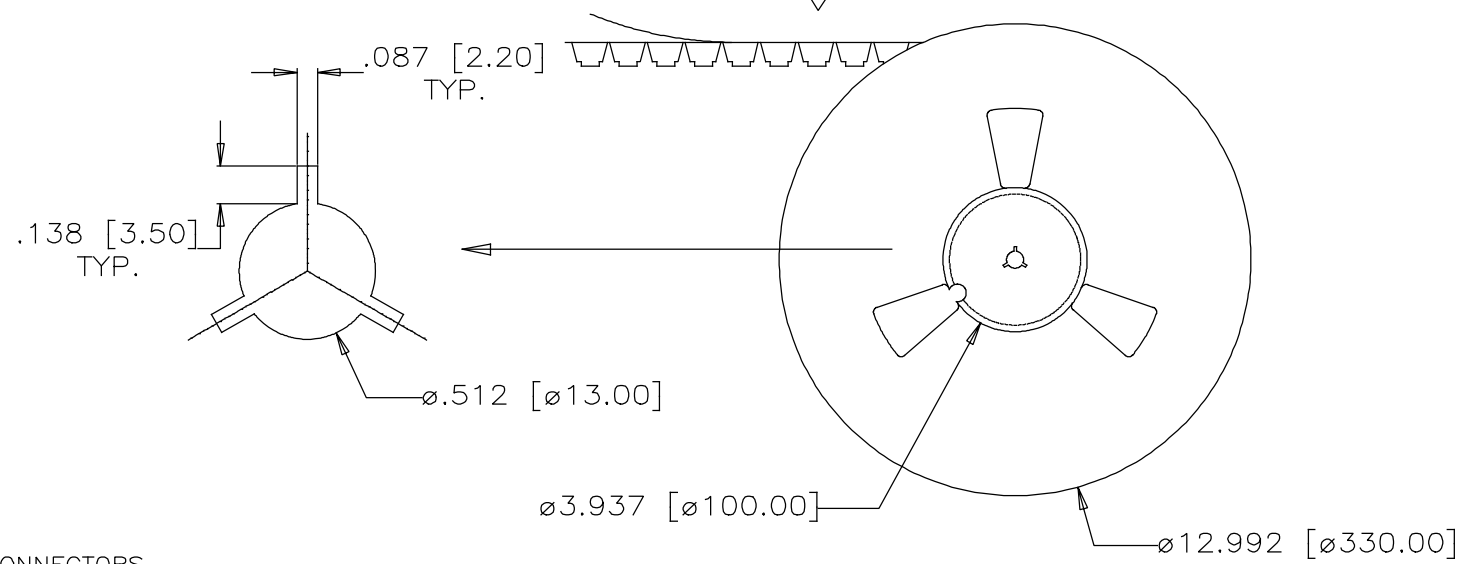
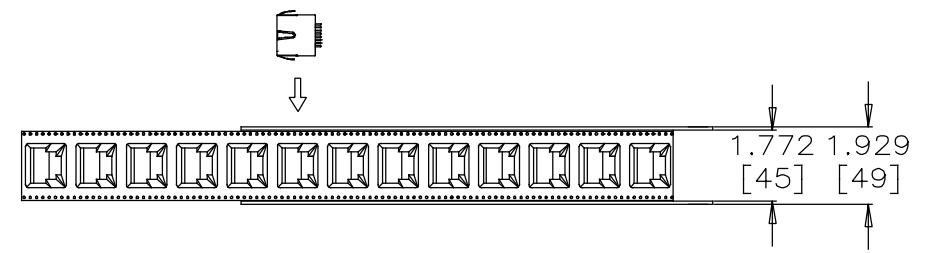
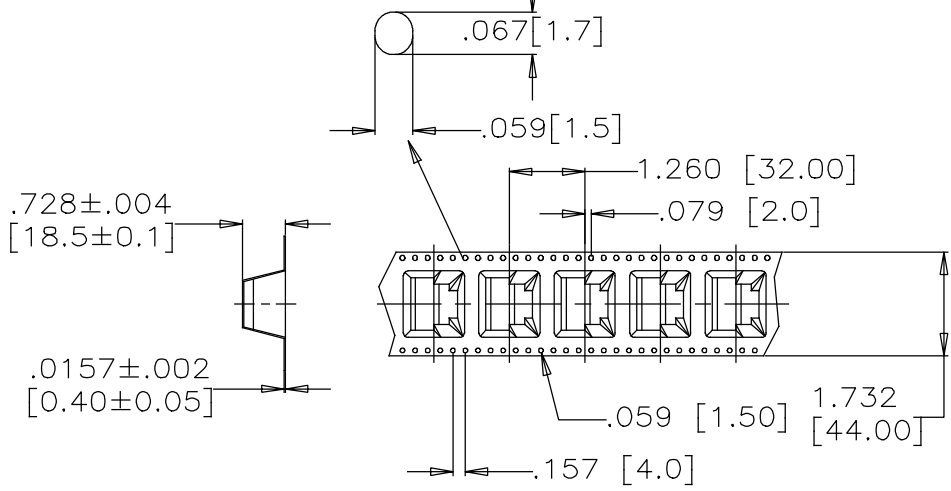

PACKAGING NOTES:

1. ONE REEL SHOULD HOLD 100 CONNECTORS.
2. 10 EMPTY CAVITIES FOR BOTH TOP AND BOTTOM OF THE CARRIER.
3. A FULLY LOADED CARTON SHOULD CONTAIN 6 REELS (600 PCS) OF CONNECTOR.

THIS DOCUMENT CONTAINS PROPRIETARY INFORMATION AND SUCH INFORMATION MAY NOT BE DISCLOSED TO OTHERS FOR ANY PURPOSE OR USED FOR MANUFACTURING PURPOSES WITHOUT WRITTEN PERMISSION FROM AMPHENOL CANADA CORP.

MATERIAL	DESIGNED	DATE	Amphenol Canada Corp.	
-----	MT.chen	27.09		
	DESIGNED	L.C	TITLE SINGLE PORT, SURFACE MOUNT RJ45	
	CHECKED		8 POSITION, 8 CONTACTS, SHIELDED	
	I. E. APPRD.		WITHOUT LIGHT PIPE, TAPE & REEL PACKAGING	
	Q. A. APPRD.		DWG	DRAWING NO.
	DWG. APPRD.		C	P-RJSSE-5382-01T
	ENG. REL. NO.		SCALE	WT. ----- SURF. ----- SHEET 2 OF 2
FINISH	DIMENSIONS ARE IN	CODE ID. NO.		
-----	INCHES [mm]	03554		