

TS3USB221A ESD Protected, High-Speed USB 2.0 (480-Mbps) 1:2 Multiplexer and Demultiplexer Switch With Single Enable

1 Features

- V_{CC} Operation at 2.5 V to 3.3 V
- $V_{I/O}$ Accepts Signals Up to 5.5 V
- 1.8-V Compatible Control-Pin Inputs
- Low-Power Mode When \overline{OE} Is Disabled (1 μ A)
- $R_{ON} = 6 \Omega$ Maximum
- $\Delta R_{ON} = 0.2 \Omega$ Typical
- $C_{I/O(on)} = 6$ pF Typical
- Low Power Consumption (30 μ A Maximum)
- High Bandwidth (900 MHz Typical)
- Latch-Up Performance Exceeds 100 mA Per JESD 78, Class II
- ESD Performance Tested Per JESD 22
 - 7000-V Human-Body Model (A114-B, Class II)
 - 1000-V Charged-Device Model (C101)
- ESD Performance I/O to GND
 - 12-kV Human-Body Model

2 Applications

- Routes Signals for USB 1.0, 1.1, and 2.0
- Mobile Phones
- Cameras
- Notebooks
- USB I/O expansion

4 Simplified Schematic

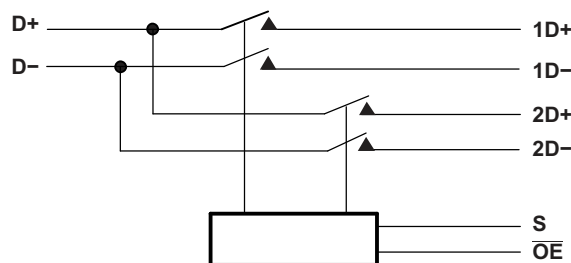

EN is the internal enable signal applied to the switch.

3 Description

The TS3USB221A device is a high-bandwidth switch specially designed for the switching of high-speed USB 2.0 signals in handset and consumer applications, such as cell phones, digital cameras, and notebooks with hubs or controllers with limited USB I/Os. The wide bandwidth (900 MHz) of this switch allows signals to pass with minimum edge and phase distortion. The device multiplexes differential outputs from a USB host device to one of two corresponding outputs. The switch is bidirectional and offers little or no attenuation of the high-speed signals at the outputs. The device also has a low power mode that will reduce the power consumption to 1 μ A for portable applications with a battery or limited power budget. The device is designed for low bit-to-bit skew and high channel-to-channel noise isolation, and is compatible with various standards, such as high-speed USB 2.0 (480 Mbps).

The TS3USB221A device integrates ESD protection cells on all pins, is available in a tiny μ QFN package (2 mm \times 1.5 mm) and is characterized over the free air temperature range from -40°C to 85°C .

Device Information⁽¹⁾

PART NUMBER	PACKAGE	BODY SIZE (NOM)
TS3USB221A	UQFN	1.50 mm \times 2.00 mm

(1) For all available packages, see the orderable addendum at the end of the datasheet.



Table of Contents

1 Features	1	8 Parameter Measurement Information	8
2 Applications	1	9 Detailed Description	12
3 Description	1	9.1 Overview	12
4 Simplified Schematic	1	9.2 Functional Block Diagram	12
5 Revision History	2	9.1 Feature Description	13
6 Pin Configuration and Functions	3	9.2 Device Functional Modes	13
7 Specifications	4	10 Application and Implementation	14
7.1 Absolute Maximum Ratings	4	10.1 Application Information	14
7.2 ESD Ratings	4	10.2 Typical Application	14
7.3 Recommended Operating Conditions	4	11 Power Supply Recommendations	16
7.4 Thermal Information	4	12 Layout	16
7.5 Electrical Characteristics	5	12.1 Layout Guidelines	16
7.6 Dynamic Electrical Characteristics, $V_{CC} = 3.3\text{ V}$ $\pm 10\%$	5	12.2 Layout Example	17
7.7 Dynamic Electrical Characteristics, $V_{CC} = 2.5\text{ V}$ $\pm 10\%$	6	13 Device and Documentation Support	18
7.8 Switching Characteristics, $V_{CC} = 3.3\text{ V} \pm 10\%$	6	13.1 Trademarks	18
7.9 Switching Characteristics, $V_{CC} = 2.5\text{ V} \pm 10\%$	6	13.2 Electrostatic Discharge Caution	18
7.10 Typical Characteristics	7	13.3 Glossary	18
		14 Mechanical, Packaging, and Orderable Information	18

5 Revision History

Changes from Original (November 2008) to Revision A	Page
• Added ESD Ratings table, Feature Description section, Device Functional Modes, Application and Implementation section, Power Supply Recommendations section, Layout section, Device and Documentation Support section, and Mechanical, Packaging, and Orderable Information section.	1
• Deleted the <i>Ordering Information</i> table from the data sheet. See the Mechanical, Packaging, and Orderable Information section for the ordering information	1
• Update the document to the new TI data sheet standard	1

6 Pin Configuration and Functions

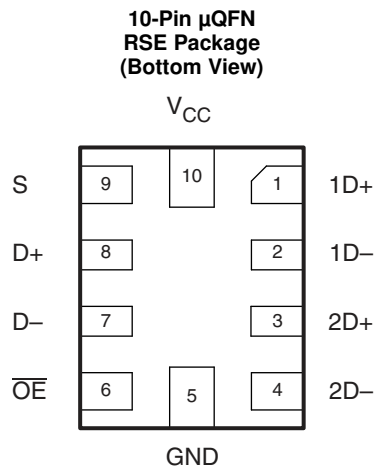
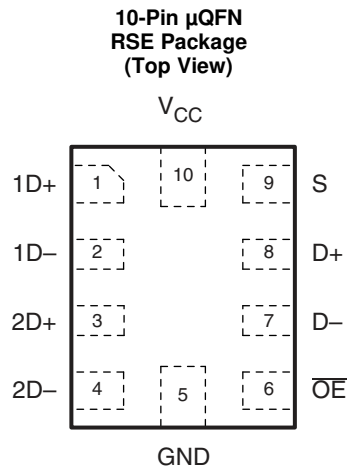

Pin Functions

PIN			DESCRIPTION
NAME	NO.	I/O	
1D+	1	I/O	USB port 1
1D-	2	I/O	
2D+	3	I/O	USB port 2
2D-	4	I/O	
GND	5	-	Ground
$\overline{\text{OE}}$	6	I	Bus-switch enable
D+	8	I/O	Common USB port
D-	7	I/O	
S	9	I	Select input
V _{CC}	10	-	Supply voltage

7 Specifications

7.1 Absolute Maximum Ratings⁽¹⁾

over operating free-air temperature range (unless otherwise noted)

		MIN	MAX	UNIT
Supply voltage, V_{CC}		-0.5	4.6	V
Control input voltage, $V_S, V_{\overline{OE}}$ ^{(2) (3)}		-0.5	7	V
Switch I/O voltage, $V_{I/O}$ ^{(2) (3) (4)}		-0.5	7	V
Control input clamp current, I_{IK}	$V_{IN} < 0$		-50	mA
I/O port clamp current, $I_{I/OK}$	$V_{I/O} < 0$		-50	mA
ON-state switch current, $I_{I/O}$ ⁽⁵⁾			±120	mA
Continuous current through V_{CC} or GND			±100	mA
T_{stg}	Storage temperature range	-65	150	°C

- (1) Stresses beyond those listed under *absolute maximum ratings* may cause permanent damage to the device. These are stress ratings only, and functional operation of the device at these or any other conditions beyond those indicated under *recommended operating conditions* is not implied. Exposure to absolute-maximum-rated conditions for extended periods may affect device reliability.
- (2) All voltages are with respect to ground, unless otherwise specified.
- (3) The input and output voltage ratings may be exceeded if the input and output clamp-current ratings are observed.
- (4) V_I and V_O are used to denote specific conditions for $V_{I/O}$.
- (5) I_I and I_O are used to denote specific conditions for $I_{I/O}$.

7.2 ESD Ratings

			VALUE	UNIT	
$V_{(ESD)}$	Electrostatic discharge	Human-body model (HBM), per ANSI/ESDA/JEDEC JS-001 ⁽¹⁾	All pins except I/O to GND	±7000	V
			I/O to GND	±12000	
		Charged-device model (CDM), per JEDEC specification JESD22-C101 ⁽²⁾	All pins	±1000	

- (1) JEDEC document JEP155 states that 500-V HBM allows safe manufacturing with a standard ESD control process. Manufacturing with less than 500-V HBM is possible with the necessary precautions.
- (2) JEDEC document JEP157 states that 250-V CDM allows safe manufacturing with a standard ESD control process. Manufacturing with less than 250-V CDM is possible with the necessary precautions.

7.3 Recommended Operating Conditions

		MIN	MAX	UNIT	
V_{CC}	Supply voltage	2.3	3.6	V	
$V_S, V_{\overline{OE}}$	High-level control input voltage	$V_{CC} = 2.3 \text{ V to } 2.7 \text{ V}$	$0.46 \times V_{CC}$	V_{CC}	V
		$V_{CC} = 2.7 \text{ V to } 3.6 \text{ V}$	$0.46 \times V_{CC}$	V_{CC}	
	Low-level control input voltage	$V_{CC} = 2.3 \text{ V to } 2.7 \text{ V}$	0	$0.25 \times V_{CC}$	V
		$V_{CC} = 2.7 \text{ V to } 3.6 \text{ V}$	0	$0.25 \times V_{CC}$	
$V_{I/O}$	Data input/output voltage	0	5.5	V	
T_A	Operating free-air temperature	-40	85	°C	

7.4 Thermal Information

THERMAL METRIC ⁽¹⁾		RSE	UNIT
		10 PINS	
$R_{\theta JA}$	Junction-to-ambient thermal resistance	179.7	°C/W
$R_{\theta JC(top)}$	Junction-to-case (top) thermal resistance	107.9	
$R_{\theta JB}$	Junction-to-board thermal resistance	100.7	
Ψ_{JT}	Junction-to-top characterization parameter	7.1	
Ψ_{JB}	Junction-to-board characterization parameter	100.0	

- (1) For more information about traditional and new thermal metrics, see the *IC Package Thermal Metrics* application report, [SPRA953](#).

7.5 Electrical Characteristics⁽¹⁾

over operating free-air temperature range (unless otherwise noted)

PARAMETER		TEST CONDITIONS	MIN	TYP ⁽²⁾	MAX	UNIT	
V _{IK}	Input-Source Clamp Voltage	V _{CC} = 3.6 V, 2.7 V, I _I = -18 mA			-1.8	V	
I _{IN}	Input leakage current, control inputs	V _{CC} = 3.6 V, 2.7 V, 0 V, V _{IN} = 0 V to 3.6 V			±1	μA	
I _{OZ} ⁽³⁾	Off-state leakage current	V _{CC} = 3.6 V, 2.7 V, V _O = 0 V to 5.25 V, V _I = 0 V, V _{IN} = V _{CC} or GND, Switch OFF			±1	μA	
I _{I(OFF)}	Power-off leakage current	V _{CC} = 0 V	V _{I/O} = 0 V to 5.25 V		±2	μA	
			V _{I/O} = 0 V to 3.6 V		±2		
			V _{I/O} = 0 V to 2.7 V		±1		
I _{CC}	Supply Current	V _{CC} = 3.6 V, 2.7 V, V _{IN} = V _{CC} or GND, I _{I/O} = 0 V, Switch ON or OFF			30	μA	
I _{CC}	Supply Current (low power mode)	V _{CC} = 3.6 V, 2.7 V, V _{IN} = V _{CC} or GND, Switch disabled, OE in high state			1	μA	
ΔI _{CC} ⁽⁴⁾	Supply-current change, control inputs	One input at 1.8 V, Other inputs at V _{CC} or GND	V _{CC} = 3.6 V		20	μA	
			V _{CC} = 2.7 V		0.5		
C _{in}	Input capacitance, control inputs	V _{CC} = 3.3 V, 2.5 V, V _{IN} = V _{CC} or 0 V		1.5	2.5	pF	
C _{io(OFF)}	OFF capacitance	V _{CC} = 3.3 V, 2.5 V, V _{I/O} = V _{CC} or 0 V, Switch OFF		3.5	5	pF	
C _{io(ON)}	ON capacitance	V _{CC} = 3.3 V, 2.5 V, V _{I/O} = V _{CC} or 0 V, Switch ON		6	7.5	pF	
R _{ON} ⁽⁵⁾	ON-state resistance	V _{CC} = 3 V, 2.3 V	V _I = 0 V, I _O = 30 mA		3	6	Ω
			V _I = 2.4 V, I _O = -15 mA		3.4	6	
ΔR _{ON}	ON-state resistance match between channels	V _{CC} = 3 V, 2.3 V	V _I = 0 V, I _O = 30 mA		0.2		Ω
			V _I = 1.7 V, I _O = -15 mA		0.2		
R _{ON(flat)}	ON-state resistance flatness	V _{CC} = 3 V, 2.3 V	V _I = 0 V, I _O = 30 mA		1		Ω
			V _I = 1.7 V, I _O = -15 mA		1		

(1) V_{IN} and I_{IN} refer to control inputs. V_I, V_O, I_I, and I_O refer to data pins.

(2) All typical values are at V_{CC} = 3.3 V (unless otherwise noted), T_A = 25°C.

(3) For I/O ports, the parameter I_{OZ} includes the input leakage current.

(4) This is the increase in supply current for each input that is at the specified TTL voltage level, rather than V_{CC} or GND.

(5) Measured by the voltage drop between the A and B terminals at the indicated current through the switch. ON-state resistance is determined by the lower of the voltages of the two (A or B) terminals.

7.6 Dynamic Electrical Characteristics, V_{CC} = 3.3 V ±10%

over operating range, T_A = -40°C to 85°C, V_{CC} = 3.3 V ±10%, GND = 0 V

PARAMETER		TEST CONDITIONS	MIN	TYP	MAX	UNIT
X _{TALK}	Crosstalk	R _L = 50 , f = 250 MHz		-40		dB
O _{IRR}	OFF isolation	R _L = 50 , f = 250 MHz		-41		dB
BW	Bandwidth (-3 dB)	R _L = 50		0.9		GHz

7.7 Dynamic Electrical Characteristics, $V_{CC} = 2.5\text{ V} \pm 10\%$

 over operating range, $T_A = -40^\circ\text{C}$ to 85°C , $V_{CC} = 2.5\text{ V} \pm 10\%$, $GND = 0\text{ V}$

PARAMETER		TEST CONDITIONS	MIN	TYP	MAX	UNIT
X_{TALK}	Crosstalk	$R_L = 50$, $f = 250\text{ MHz}$		-39		dB
O_{IRR}	OFF isolation	$R_L = 50$, $f = 250\text{ MHz}$		-40		dB
BW	Bandwidth (3 dB)	$R_L = 50$		0.9		GHz

7.8 Switching Characteristics, $V_{CC} = 3.3\text{ V} \pm 10\%$

 over operating range, $T_A = -40^\circ\text{C}$ to 85°C , $V_{CC} = 3.3\text{ V} \pm 10\%$, $GND = 0\text{ V}$

PARAMETER			MIN	TYP ⁽¹⁾	MAX	UNIT
t_{pd}	Propagation delay ⁽²⁾ ⁽³⁾			0.25		ns
t_{ON}	Line enable time	S to D, nD			30	ns
		\overline{OE} to D, nD			17	
t_{OFF}	Line disable time	S to D, nD			12	ns
		\overline{OE} to D, nD			10	
$t_{SK(O)}$	Output skew between center port to any other port ⁽²⁾			0.1	0.2	ns
$t_{SK(P)}$	Skew between opposite transitions of the same output ($t_{PHL} - t_{PLH}$) ⁽²⁾			0.1	0.2	ns

(1) For Max or Min conditions, use the appropriate value specified under Electrical Characteristics for the applicable device type.

(2) Specified by design

(3) The bus switch contributes no propagational delay other than the RC delay of the on resistance of the switch and the load capacitance. The time constant for the switch alone is of the order of 0.25 ns for 10-pF load. Since this time constant is much smaller than the rise/fall times of typical driving signals, it adds very little propagational delay to the system. Propagational delay of the bus switch, when used in a system, is determined by the driving circuit on the driving side of the switch and its interactions with the load on the driven side.

7.9 Switching Characteristics, $V_{CC} = 2.5\text{ V} \pm 10\%$

 over operating range, $T_A = -40^\circ\text{C}$ to 85°C , $V_{CC} = 2.5\text{ V} \pm 10\%$, $GND = 0\text{ V}$

PARAMETER			MIN	TYP ⁽¹⁾	MAX	UNIT
t_{pd}	Propagation delay ⁽²⁾ ⁽³⁾			0.25		ns
t_{ON}	Line enable time	S to D, nD			50	ns
		\overline{OE} to D, nD			32	
t_{OFF}	Line disable time	S to D, nD			23	ns
		\overline{OE} to D, nD			12	
$t_{SK(O)}$	Output skew between center port to any other port ⁽²⁾			0.1	0.2	ns
$t_{SK(P)}$	Skew between opposite transitions of the same output ($t_{PHL} - t_{PLH}$) ⁽²⁾			0.1	0.2	ns

(1) For Max or Min conditions, use the appropriate value specified under Electrical Characteristics for the applicable device type.

(2) Specified by design

(3) The bus switch contributes no propagational delay other than the RC delay of the on resistance of the switch and the load capacitance. The time constant for the switch alone is of the order of 0.25 ns for 10-pF load. Since this time constant is much smaller than the rise/fall times of typical driving signals, it adds very little propagational delay to the system. Propagational delay of the bus switch, when used in a system, is determined by the driving circuit on the driving side of the switch and its interactions with the load on the driven side.

7.10 Typical Characteristics

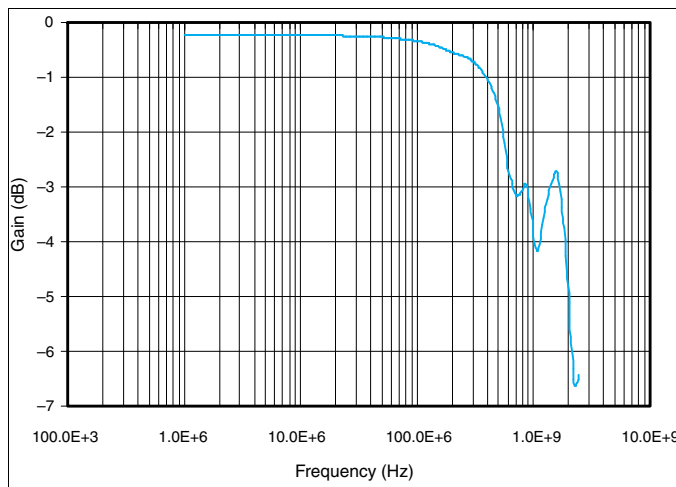

Figure 1. Gain vs Frequency

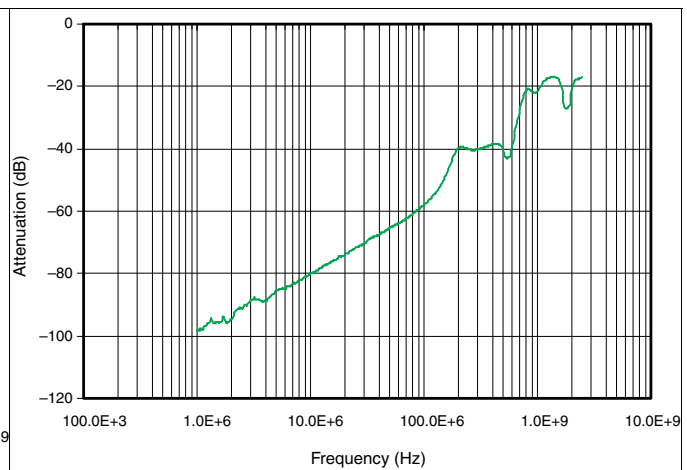

Figure 2. OFF Isolation vs Frequency

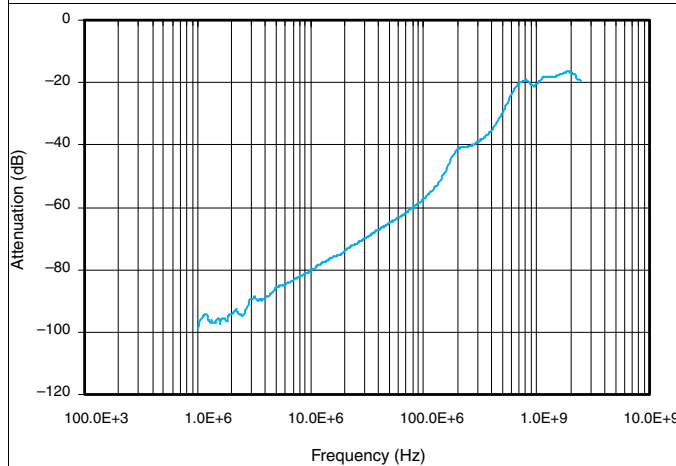

Figure 3. Crosstalk vs Frequency

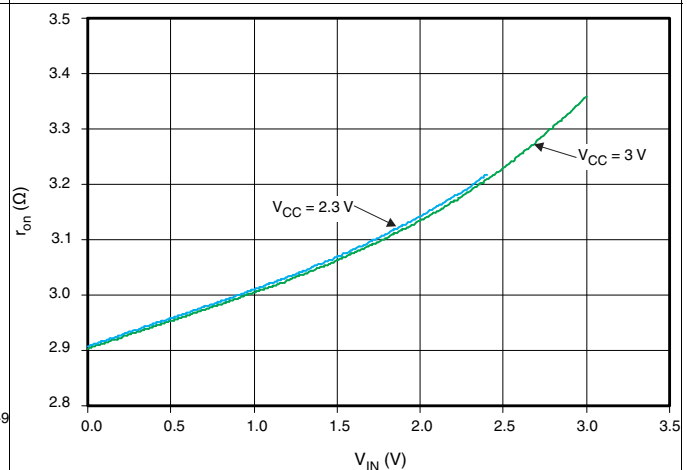

Figure 4. r_{on} vs V_{IN} ($I_{OUT} = -15$ mA)

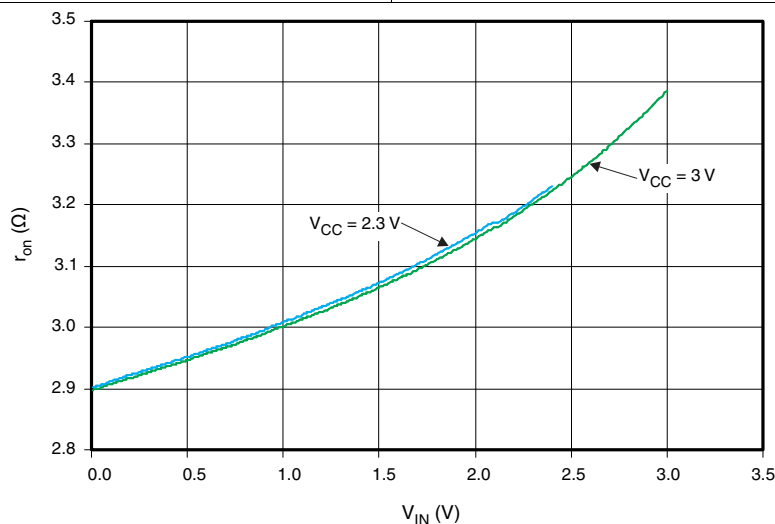
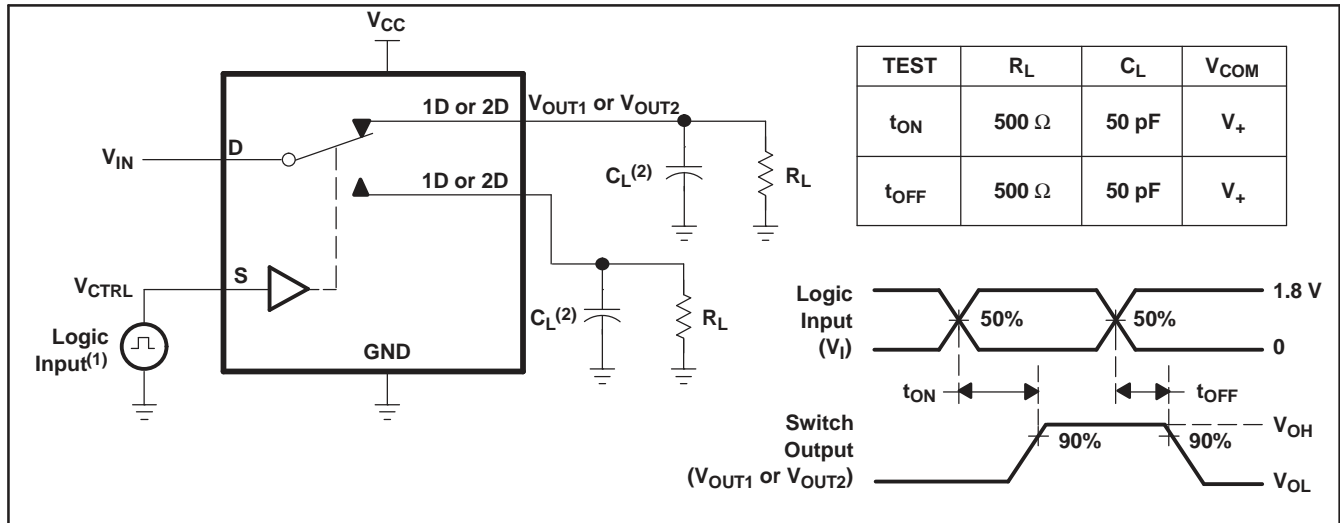

Figure 5. r_{ON} vs V_{IN} ($I_{OUT} = 30$ mA)

8 Parameter Measurement Information



- (1) All input pulses are supplied by generators having the following characteristics: PRR ≤ 10 MHz, Z_O = 50 Ω, t_r < 5 ns, t_f < 5 ns.
 (2) C_L includes probe and jig capacitance.

Figure 6. Turn-On (t_{ON}) and Turn-Off Time (t_{OFF})

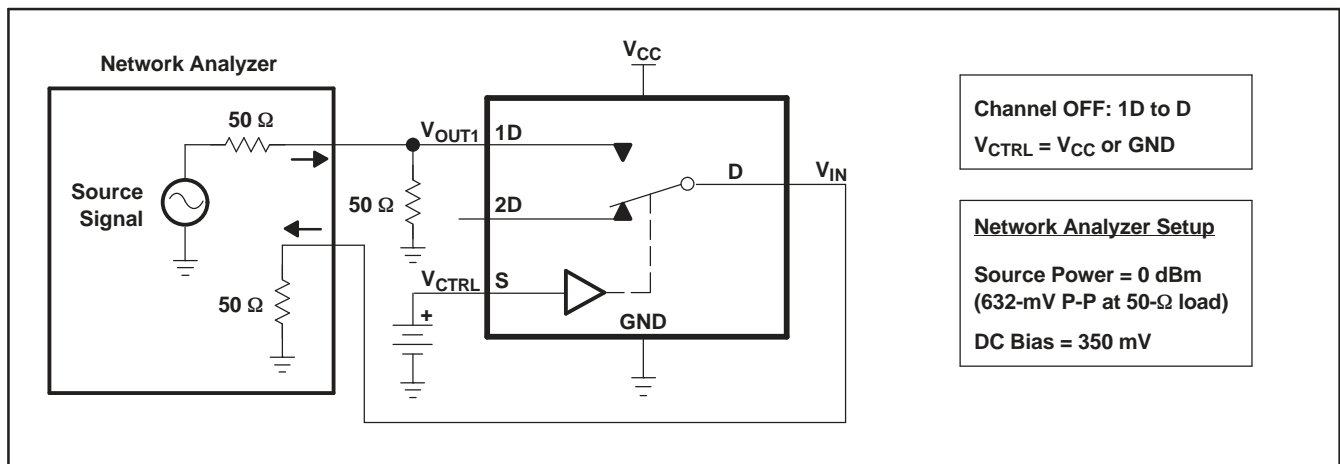

Figure 7. OFF Isolation (O_{ISO})

Parameter Measurement Information (continued)

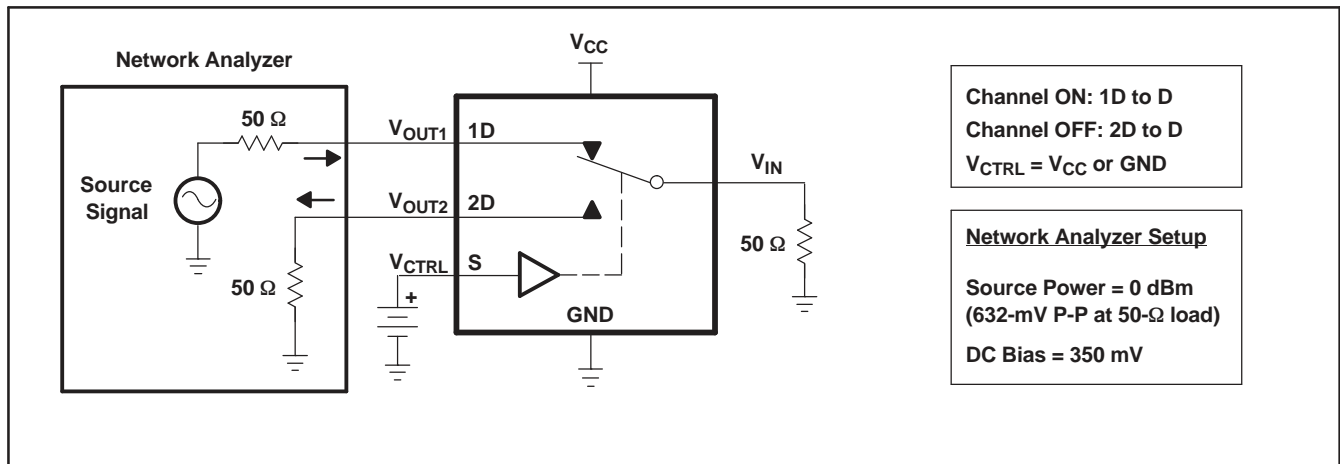

Figure 8. Crosstalk (X_{TALK})

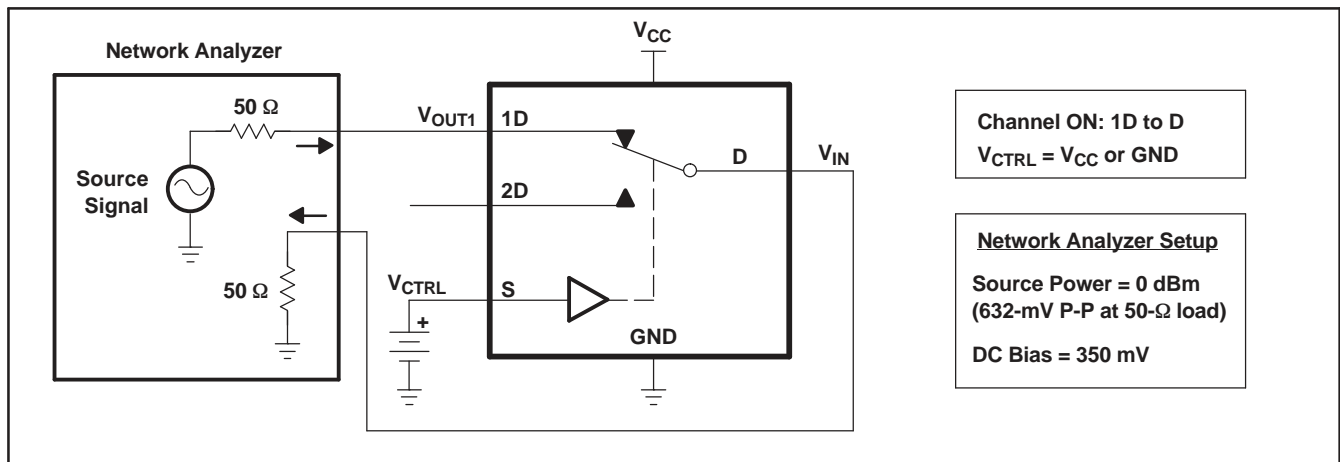

Figure 9. Bandwidth (BW)

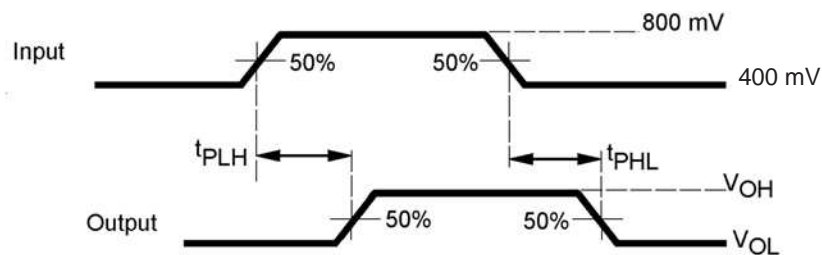

Figure 10. Propagation Delay

Parameter Measurement Information (continued)

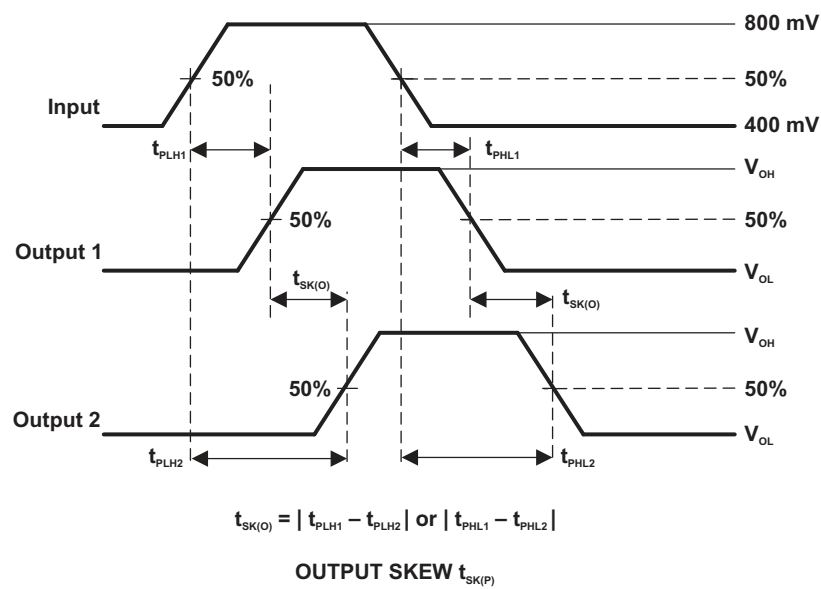
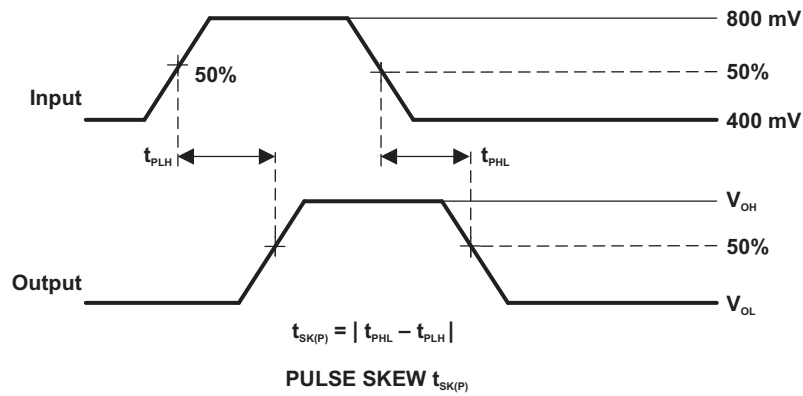

Figure 11. Skew Test

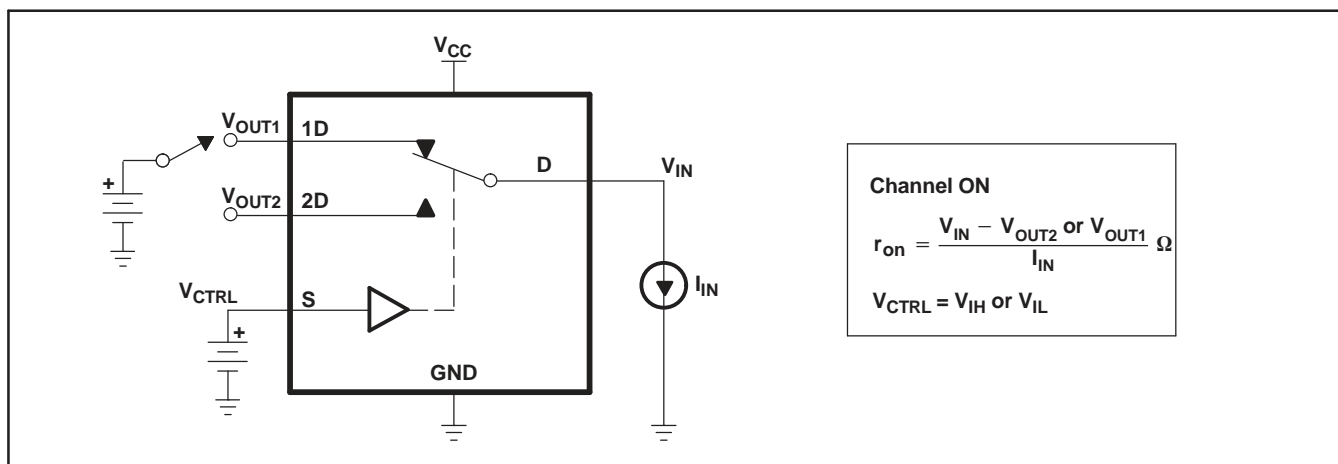

Figure 12. ON-State Resistance (r_{on})

Parameter Measurement Information (continued)

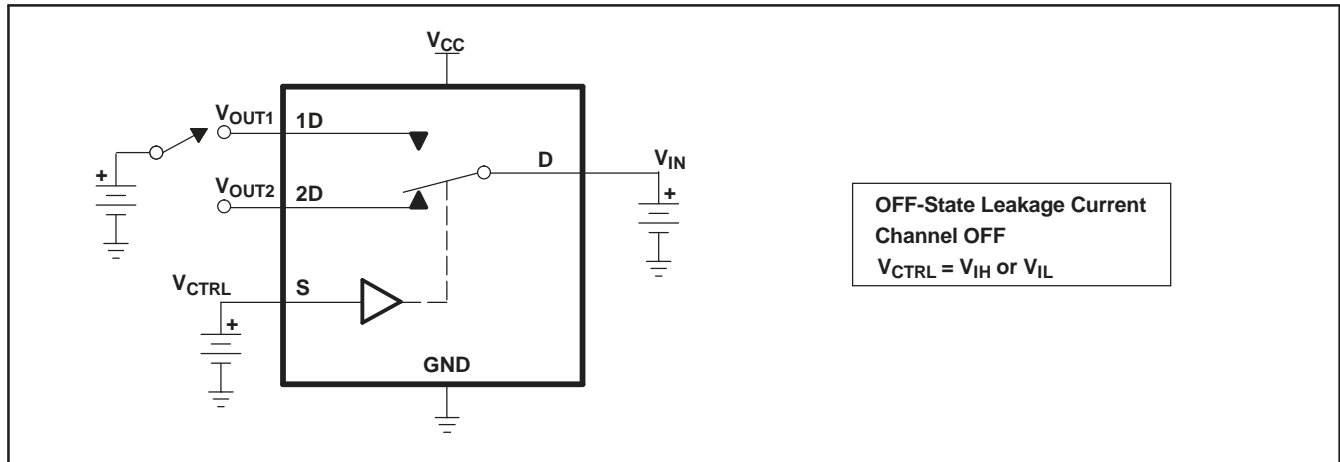

Figure 13. OFF-State Leakage Current

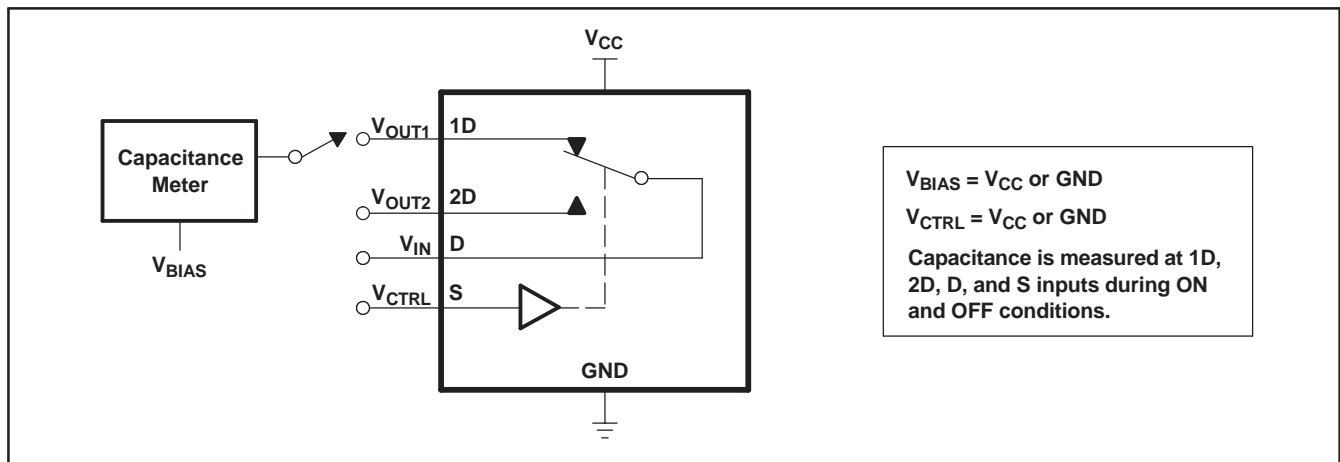

Figure 14. Capacitance

9 Detailed Description

9.1 Overview

The TS3USB221A device is a 2-channel SPDT switch specially designed for the switching of high-speed USB 2.0 signals in handset and consumer applications, such as cell phones, digital cameras, and notebooks with hubs or controllers with limited USB I/Os. The wide bandwidth (900 MHz) of this switch allows signals to pass with minimum edge and phase distortion. The device multiplexes differential outputs from a USB host device to one of two corresponding outputs. The switch is bidirectional and offers little or no attenuation of the high-speed signals at the outputs. The device also has a low power mode that will reduce the power consumption to 1 μ A for portable applications with a battery or limited power budget.

The device is designed for low bit-to-bit skew and high channel-to-channel noise isolation, and is compatible with various standards, such as high-speed USB 2.0 (480 Mbps).

The TS3USB221A device integrates ESD protection cells on all pins, is available in a tiny μ QFN package (2 mm \times 1.5 mm) and is characterized over the free air temperature range from -40°C to 85°C .

9.2 Functional Block Diagram

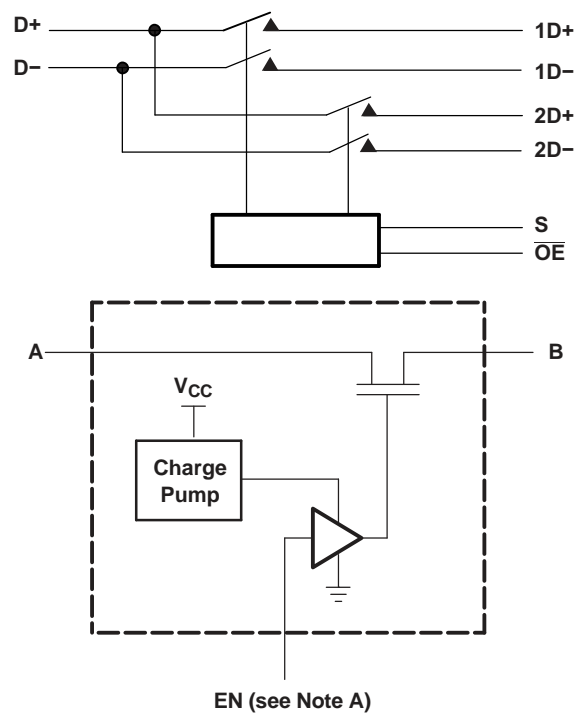

- A. EN is the internal enable signal applied to the switch.

Figure 15. Simplified Schematic of Each FET Switch (SW)

9.1 Feature Description

9.1.1 Low Power Mode

The TS3USB221A has a low power mode that reduces the power consumption to 1 μ A while the device is not in use. To put the device in low power mode and disable the switch, the bus-switch enable pin \overline{OE} must be supplied with a logic "High" signal.

9.2 Device Functional Modes

Table 1. Truth Table

S	\overline{OE}	FUNCTION
X	H	Disconnect
L	L	D = 1D
H	L	D = 2D

10 Application and Implementation

NOTE

Information in the following applications sections is not part of the TI component specification, and TI does not warrant its accuracy or completeness. TI's customers are responsible for determining suitability of components for their purposes. Customers should validate and test their design implementation to confirm system functionality.

10.1 Application Information

There are many USB applications in which the USB hubs or controllers have a limited number of USB I/Os. The TS3USB221A solution can effectively expand the limited USB I/Os by switching between multiple USB buses in order to interface them to a single USB hub or controller.

10.2 Typical Application

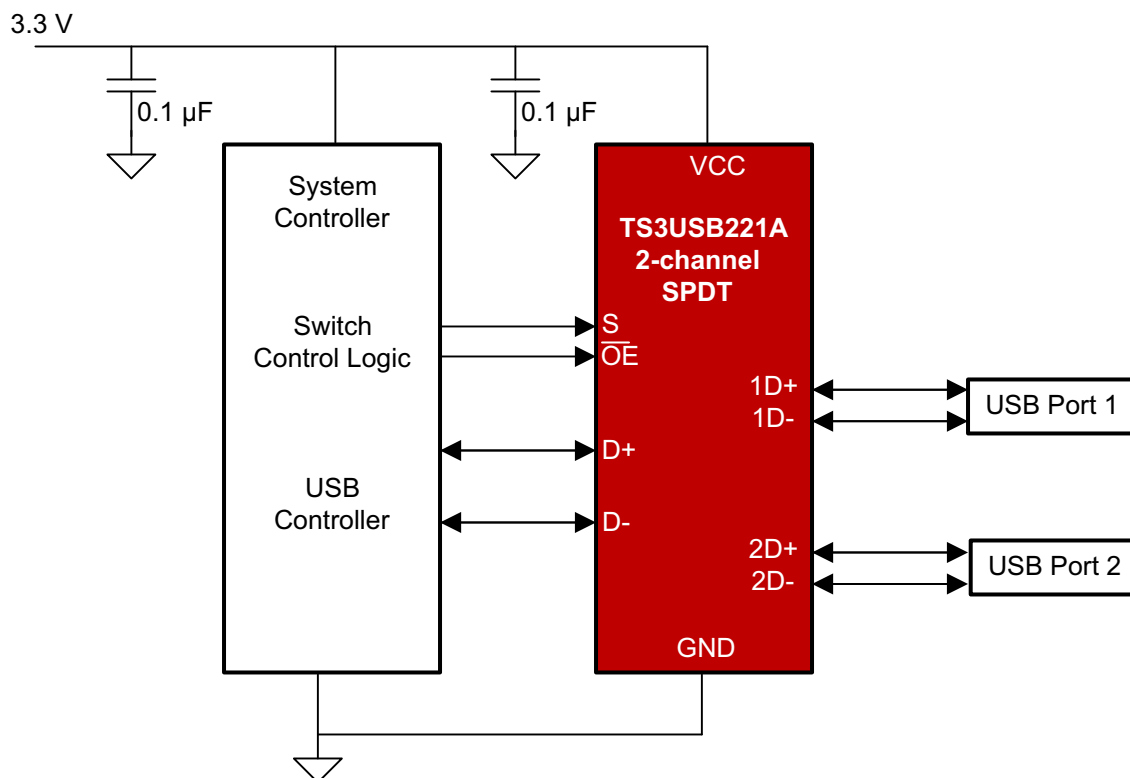

Figure 16. Application Schematic

Typical Application (continued)

10.2.1 Design Requirements

Design requirements of the USB 1.0, 1.1, and 2.0 standards should be followed.

It is recommended that the digital control pins S and \overline{OE} be pulled up to V_{CC} or down to GND to avoid undesired switch positions that could result from the floating pin.

10.2.2 Detailed Design Procedure

The TS3USB221A can be properly operated without any external components. However, it is recommended that unused pins should be connected to ground through a 50- Ω resistor to prevent signal reflections back into the device.

10.2.3 Application Curves

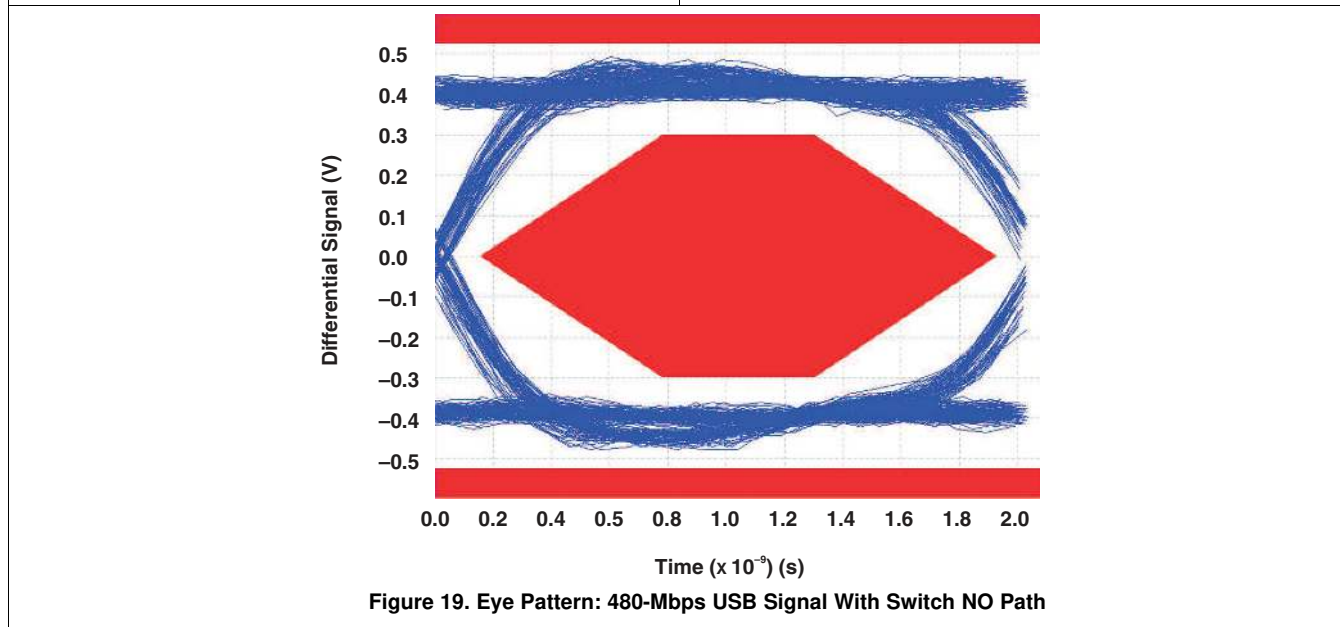
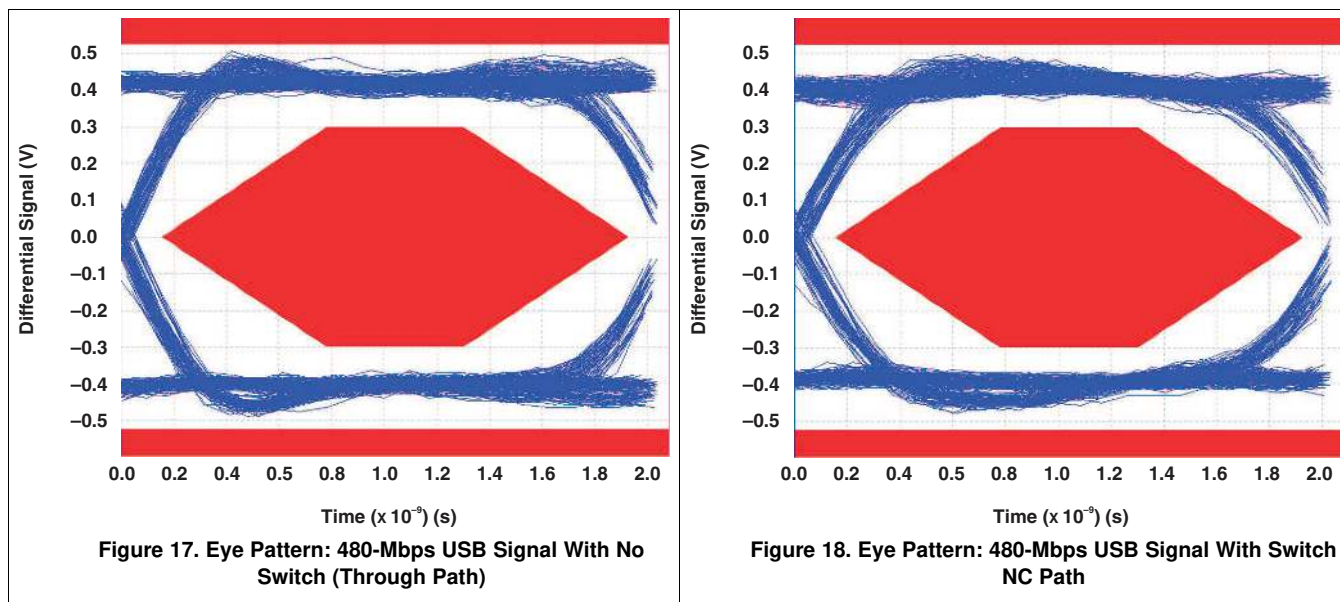

11 Power Supply Recommendations

Power to the device is supplied through the VCC pin and should follow the USB 1.0, 1.1, and 2.0 standards. A bypass capacitor is recommended to be placed as close to the supply pin VCC to help smooth out lower frequency noise to provide better load regulation across the frequency spectrum.

12 Layout

12.1 Layout Guidelines

Place supply bypass capacitors as close to VCC pin as possible and avoid placing the bypass caps near the D+/D- traces.

The high speed D+/D- traces should always be matched lengths and must be no more than 4 inches; otherwise, the eye diagram performance may be degraded. A high-speed USB connection is made through a shielded, twisted pair cable with a differential characteristic impedance. In layout, the impedance of D+ and D- traces should match the cable characteristic differential impedance for optimal performance.

Route the high-speed USB signals using a minimum of vias and corners which will reduce signal reflections and impedance changes. When a via must be used, increase the clearance size around it to minimize its capacitance. Each via introduces discontinuities in the signal's transmission line and increases the chance of picking up interference from the other layers of the board. Be careful when designing test points on twisted pair lines; through-hole pins are not recommended.

When it becomes necessary to turn 90°, use two 45° turns or an arc instead of making a single 90° turn. This reduces reflections on the signal traces by minimizing impedance discontinuities.

Do not route USB traces under or near crystals, oscillators, clock signal generators, switching regulators, mounting holes, magnetic devices or IC's that use or duplicate clock signals.

Avoid stubs on the high-speed USB signals because they cause signal reflections. If a stub is unavoidable, then the stub should be less than 200 mm.

Route all high-speed USB signal traces over continuous planes (VCC or GND), with no interruptions.

Avoid crossing over anti-etch, commonly found with plane splits.

Due to high frequencies associated with the USB, a printed circuit board with at least four layers is recommended; two signal layers separated by a ground and power layer as shown in [Figure 20](#).

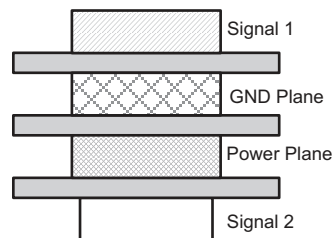

Figure 20. Four-Layer Board Stack-Up

The majority of signal traces should run on a single layer, preferably Signal 1. Immediately next to this layer should be the GND plane, which is solid with no cuts. Avoid running signal traces across a split in the ground or power plane. When running across split planes is unavoidable, sufficient decoupling must be used. Minimizing the number of signal vias reduces EMI by reducing inductance at high frequencies.

12.2 Layout Example

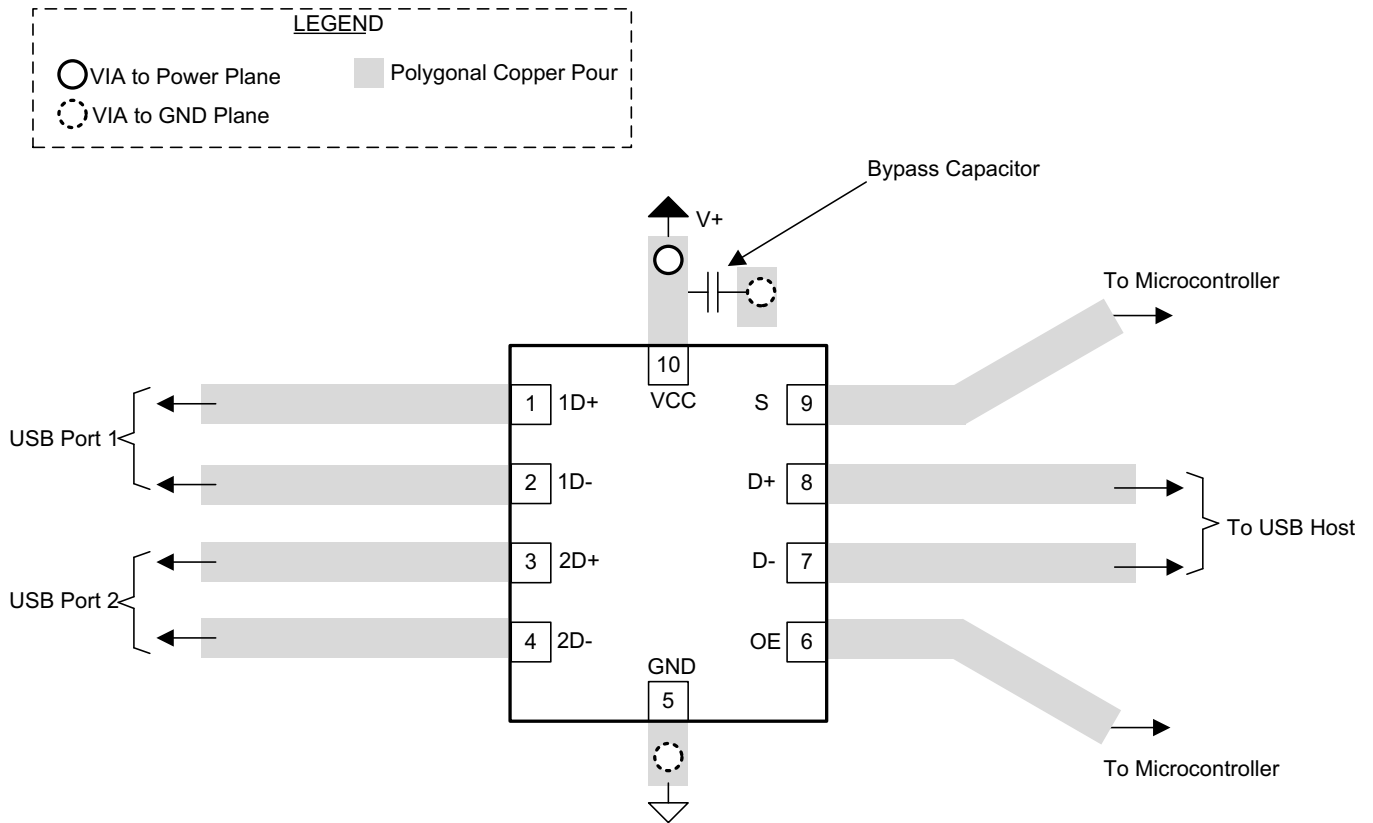

Figure 21. Package Layout Diagram

13 Device and Documentation Support

13.1 Trademarks

All trademarks are the property of their respective owners.

13.2 Electrostatic Discharge Caution



These devices have limited built-in ESD protection. The leads should be shorted together or the device placed in conductive foam during storage or handling to prevent electrostatic damage to the MOS gates.

13.3 Glossary

[SLYZ022](#) — *TI Glossary*.

This glossary lists and explains terms, acronyms, and definitions.

14 Mechanical, Packaging, and Orderable Information

The following pages include mechanical, packaging, and orderable information. This information is the most current data available for the designated devices. This data is subject to change without notice and revision of this document. For browser-based versions of this data sheet, refer to the left-hand navigation.

PACKAGING INFORMATION

Orderable Device	Status (1)	Package Type	Package Drawing	Pins	Package Qty	Eco Plan (2)	Lead finish/ Ball material (6)	MSL Peak Temp (3)	Op Temp (°C)	Device Marking (4/5)	Samples
TS3USB221ARSER	ACTIVE	UQFN	RSE	10	3000	RoHS & Green	NIPDAU	Level-1-260C-UNLIM	-40 to 85	(LH7, LHR, LHV)	Samples
TS3USB221ARSERG4	ACTIVE	UQFN	RSE	10	3000	RoHS & Green	NIPDAU	Level-1-260C-UNLIM	-40 to 85	(LH7, LHR, LHV)	Samples

(1) The marketing status values are defined as follows:

ACTIVE: Product device recommended for new designs.

LIFEBUY: TI has announced that the device will be discontinued, and a lifetime-buy period is in effect.

NRND: Not recommended for new designs. Device is in production to support existing customers, but TI does not recommend using this part in a new design.

PREVIEW: Device has been announced but is not in production. Samples may or may not be available.

OBSOLETE: TI has discontinued the production of the device.

(2) **RoHS:** TI defines "RoHS" to mean semiconductor products that are compliant with the current EU RoHS requirements for all 10 RoHS substances, including the requirement that RoHS substance do not exceed 0.1% by weight in homogeneous materials. Where designed to be soldered at high temperatures, "RoHS" products are suitable for use in specified lead-free processes. TI may reference these types of products as "Pb-Free".

RoHS Exempt: TI defines "RoHS Exempt" to mean products that contain lead but are compliant with EU RoHS pursuant to a specific EU RoHS exemption.

Green: TI defines "Green" to mean the content of Chlorine (Cl) and Bromine (Br) based flame retardants meet JS709B low halogen requirements of <=1000ppm threshold. Antimony trioxide based flame retardants must also meet the <=1000ppm threshold requirement.

(3) MSL, Peak Temp. - The Moisture Sensitivity Level rating according to the JEDEC industry standard classifications, and peak solder temperature.

(4) There may be additional marking, which relates to the logo, the lot trace code information, or the environmental category on the device.

(5) Multiple Device Markings will be inside parentheses. Only one Device Marking contained in parentheses and separated by a "~" will appear on a device. If a line is indented then it is a continuation of the previous line and the two combined represent the entire Device Marking for that device.

(6) Lead finish/Ball material - Orderable Devices may have multiple material finish options. Finish options are separated by a vertical ruled line. Lead finish/Ball material values may wrap to two lines if the finish value exceeds the maximum column width.

Important Information and Disclaimer:The information provided on this page represents TI's knowledge and belief as of the date that it is provided. TI bases its knowledge and belief on information provided by third parties, and makes no representation or warranty as to the accuracy of such information. Efforts are underway to better integrate information from third parties. TI has taken and continues to take reasonable steps to provide representative and accurate information but may not have conducted destructive testing or chemical analysis on incoming materials and chemicals. TI and TI suppliers consider certain information to be proprietary, and thus CAS numbers and other limited information may not be available for release.

In no event shall TI's liability arising out of such information exceed the total purchase price of the TI part(s) at issue in this document sold by TI to Customer on an annual basis.

OTHER QUALIFIED VERSIONS OF TS3USB221A :

- Automotive : [TS3USB221A-Q1](#)

NOTE: Qualified Version Definitions:

- Automotive - Q100 devices qualified for high-reliability automotive applications targeting zero defects

TAPE AND REEL INFORMATION

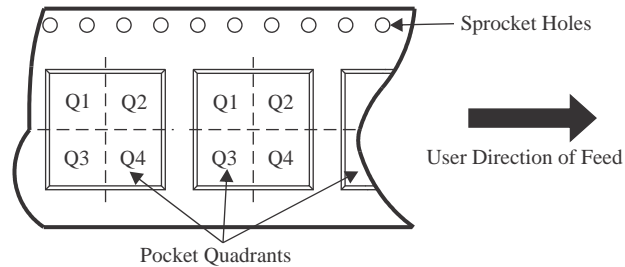
QUADRANT ASSIGNMENTS FOR PIN 1 ORIENTATION IN TAPE

*All dimensions are nominal

Device	Package Type	Package Drawing	Pins	SPQ	Reel Diameter (mm)	Reel Width W1 (mm)	A0 (mm)	B0 (mm)	K0 (mm)	P1 (mm)	W (mm)	Pin1 Quadrant
TS3USB221ARSER	UQFN	RSE	10	3000	180.0	9.5	1.7	2.2	0.75	4.0	8.0	Q1
TS3USB221ARSER	UQFN	RSE	10	3000	180.0	9.5	1.7	2.3	0.75	4.0	8.0	Q1

TAPE AND REEL BOX DIMENSIONS

*All dimensions are nominal

Device	Package Type	Package Drawing	Pins	SPQ	Length (mm)	Width (mm)	Height (mm)
TS3USB221ARSER	UQFN	RSE	10	3000	189.0	185.0	36.0
TS3USB221ARSER	UQFN	RSE	10	3000	184.0	184.0	19.0

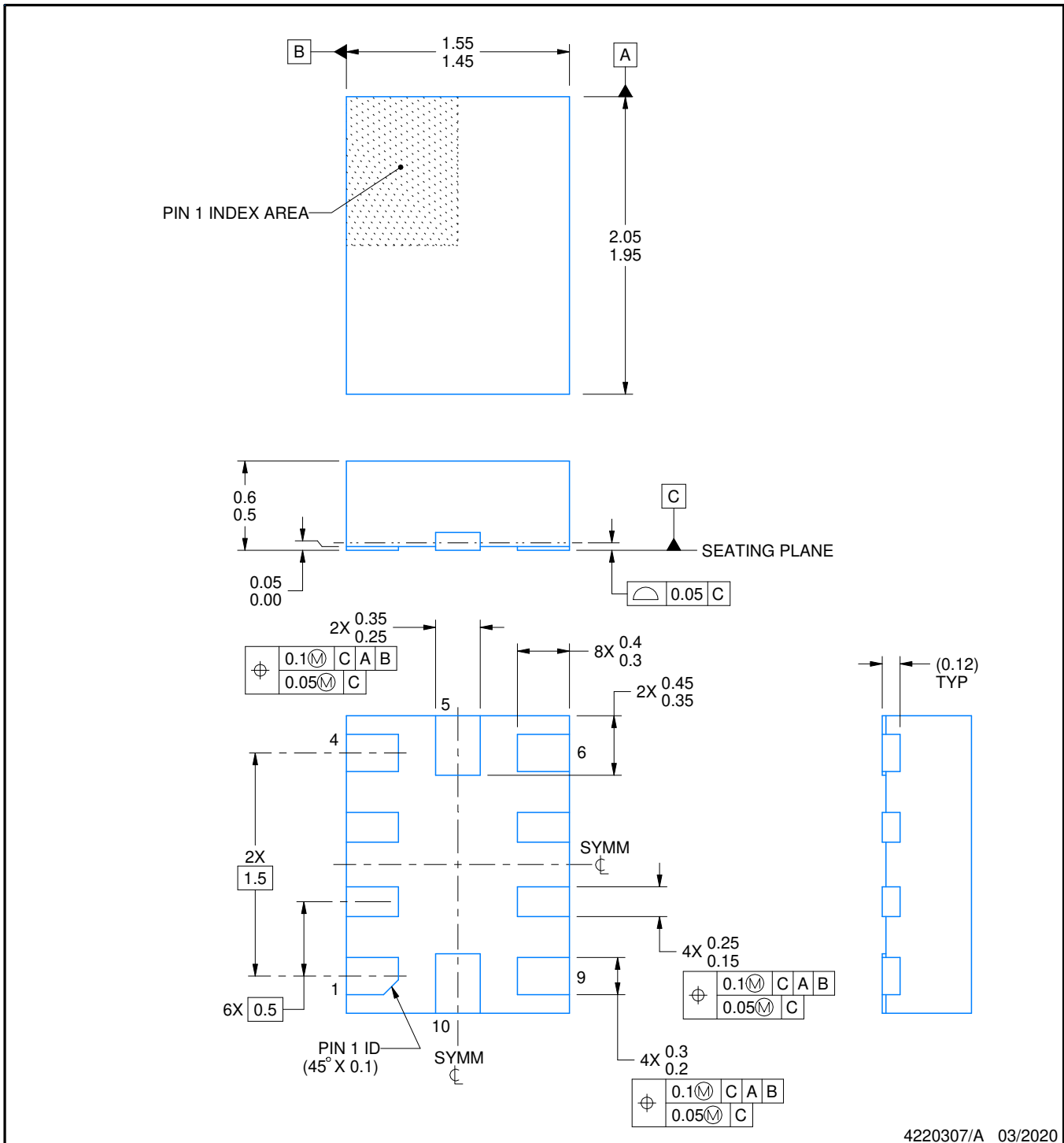
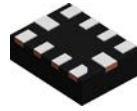

4220307/A 03/2020

NOTES:

1. All linear dimensions are in millimeters. Any dimensions in parenthesis are for reference only. Dimensioning and tolerancing per ASME Y14.5M.
2. This drawing is subject to change without notice.

EXAMPLE BOARD LAYOUT

RSE0010A

UQFN - 0.6 mm max height

PLASTIC QUAD FLATPACK - NO LEAD

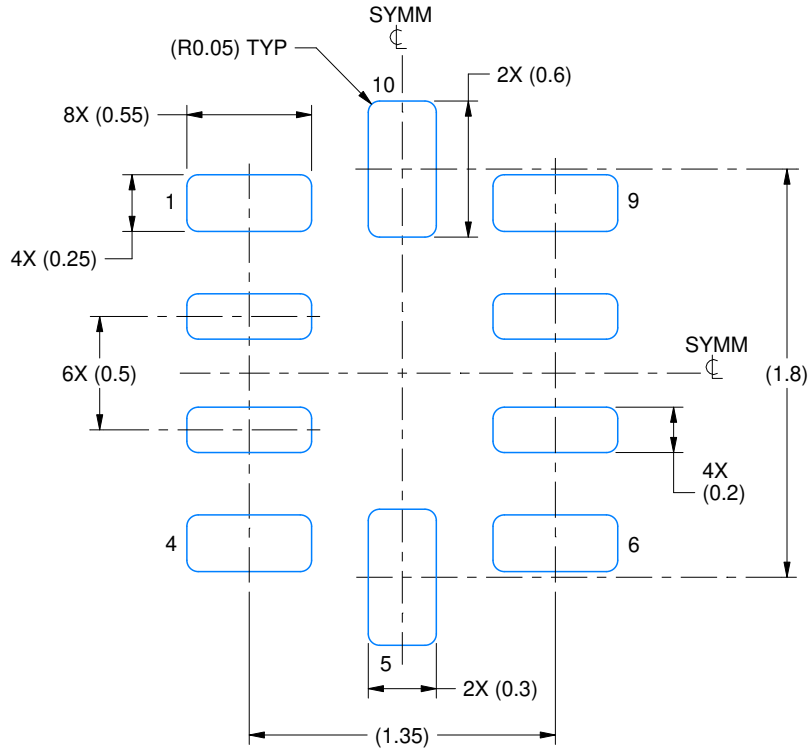

LAND PATTERN EXAMPLE
EXPOSED METAL SHOWN
SCALE:30X

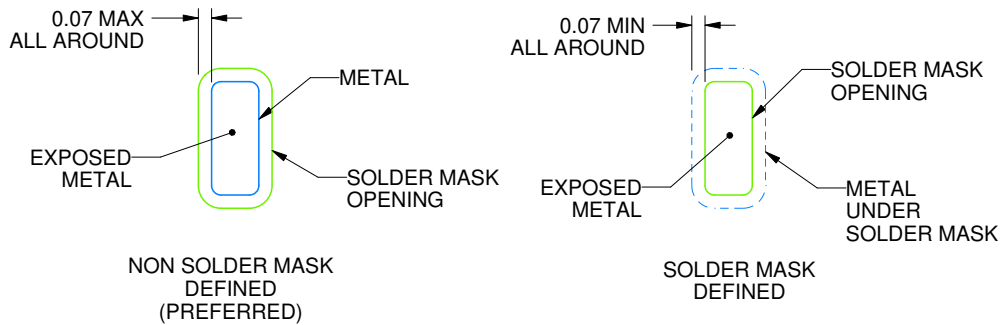

SOLDER MASK DETAILS
NOT TO SCALE

4220307/A 03/2020

NOTES: (continued)

3. For more information, see Texas Instruments literature number SLUA271 (www.ti.com/lit/slua271).

EXAMPLE STENCIL DESIGN

RSE0010A

UQFN - 0.6 mm max height

PLASTIC QUAD FLATPACK - NO LEAD

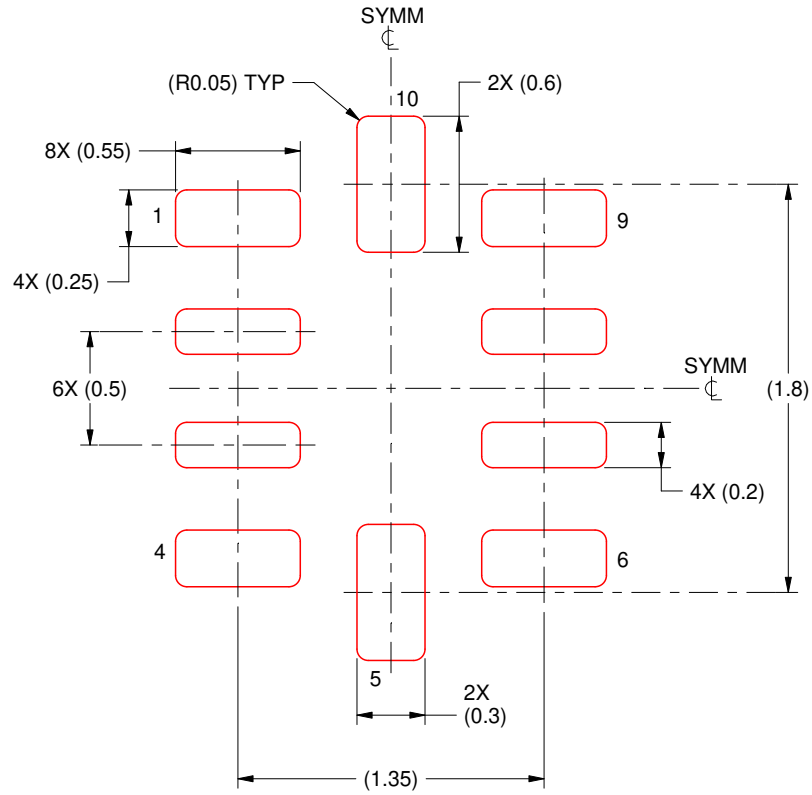

SOLDER PASTE EXAMPLE
BASED ON 0.1 mm THICKNESS
SCALE: 30X

4220307/A 03/2020

NOTES: (continued)

5. Laser cutting apertures with trapezoidal walls and rounded corners may offer better paste release. IPC-7525 may have alternate design recommendations.

IMPORTANT NOTICE AND DISCLAIMER

TI PROVIDES TECHNICAL AND RELIABILITY DATA (INCLUDING DATA SHEETS), DESIGN RESOURCES (INCLUDING REFERENCE DESIGNS), APPLICATION OR OTHER DESIGN ADVICE, WEB TOOLS, SAFETY INFORMATION, AND OTHER RESOURCES "AS IS" AND WITH ALL FAULTS, AND DISCLAIMS ALL WARRANTIES, EXPRESS AND IMPLIED, INCLUDING WITHOUT LIMITATION ANY IMPLIED WARRANTIES OF MERCHANTABILITY, FITNESS FOR A PARTICULAR PURPOSE OR NON-INFRINGEMENT OF THIRD PARTY INTELLECTUAL PROPERTY RIGHTS.

These resources are intended for skilled developers designing with TI products. You are solely responsible for (1) selecting the appropriate TI products for your application, (2) designing, validating and testing your application, and (3) ensuring your application meets applicable standards, and any other safety, security, regulatory or other requirements.

These resources are subject to change without notice. TI grants you permission to use these resources only for development of an application that uses the TI products described in the resource. Other reproduction and display of these resources is prohibited. No license is granted to any other TI intellectual property right or to any third party intellectual property right. TI disclaims responsibility for, and you will fully indemnify TI and its representatives against, any claims, damages, costs, losses, and liabilities arising out of your use of these resources.

TI's products are provided subject to [TI's Terms of Sale](#) or other applicable terms available either on [ti.com](https://www.ti.com) or provided in conjunction with such TI products. TI's provision of these resources does not expand or otherwise alter TI's applicable warranties or warranty disclaimers for TI products.

TI objects to and rejects any additional or different terms you may have proposed.

Mailing Address: Texas Instruments, Post Office Box 655303, Dallas, Texas 75265
Copyright © 2023, Texas Instruments Incorporated