

RECOMMENDED PCB LAYOUT

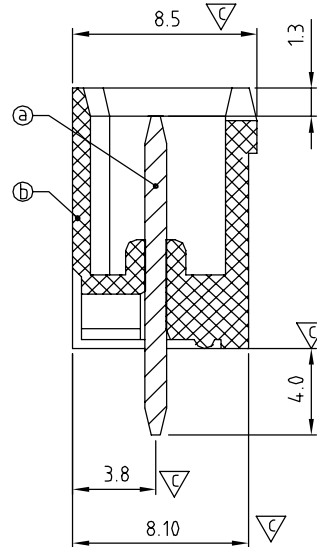

N = Number of poles  
 Dim A =  $N \times 5.0 + 2$   
 Dim B =  $(N - 1) \times 5.0$

	Dim A	Dim B
2-6p	±0.15	±0.15
7-12p	±0.20	±0.20
13-18p	±0.30	±0.30
19-24p	±0.40	±0.40

SIGN	DATE	DESCRIPTION	APPROVER
△	8/16'06	Added VDE and TUV standard	Steady
△	8/16'06	Current rating (cULus) changed from 10A to 20A	Steady
△	1/19'07	Soldering temperature changed from 245° to 250°	Tony
△	2009.10.21	The material is changed from Brass to Copper	Jacke
△	2009.10.21	The operating temperature is changed	Jacke
△	2010.05.29	The design is changed	Jacke
△	2013.04.10	Update the drawing	Chen Bo

THIS IS CAD DRAWING, DO NOT REVISE MANUALLY!!!

Material:

- △ Item ① Male contact pin: Copper Tin plated
- Item ② Terminal(housing): Thermoplastic (UL94V-0)

- △ Electrical: cULus /VDE /TUV
- Voltage rating: 300V/300V/300V
- △ Current rating: 20A/20A/20A
- Withstanding Voltage: 1.6 KV/2.5KV/2.5KV
- △ Operating temperature: -40°C to +115°C
- △ Soldering temperature: 260°C±5°C/5 Sec
- Safety Approval:
- Critical dimension:

OQ xx 7 1 x 0 xxxx G

- No. OF POLES ———— G RoHS compliant (lead<4%) In copper Alloy
- 02: 2 POLES
- 24: 24 POLES
- 0000: "@ Logo (Standard)
- 000A: "ANYTEK" Mark
- Any special item by customer request. please contact sales department.
- 0 Black (RAL9005)
- 2 Red (RAL3001/D)
- 3 Orange(RAL2011/P)
- 4 Yellow(RAL1018/A)
- 5 Green(RAL6018/T)
- 6 Blue (RAL5015/A)
- 8 Grey(RAL7035/D)
- 9 White(RAL1102)
- C Green(RAL6018/U)

<b>ANYTEK</b>				<b>CUSTOMER COPY</b>			
ALL RIGHTS RESERVED. REPRODUCTION OR ISSUE TO THIRD PARTIES IN ANY FORM WHATSOEVER IS NOT PERMITTED WITHOUT WRITTEN AUTHORITY FROM THE PROPRIETOR. PROPERTY OF ANYTEK TECHNOLOGY CO., LTD							
TITLE		OQ 5.0mm 180° /Close Series 2p-24p					
PART NO.		OQxx71x0xxxxG			DWG NO.		80Q0503
APPROVED		DESIGNED	DRAWN	CUST NO.		Tolerance	
		Chen Bo 04/10'13	Chen Bo 04/10'13			X. ±0.50	
				SHEET: 01/01		X.X ±0.30	
				UNIT: mm		X.XX ±0.10	
				SCALE: NONE		X° ±1°	
				REV: J			