

CUSTOMER TERMINAL	RoHS	LEAD(Pb)-FREE
Sn96%, Ag4%	Yes	Yes

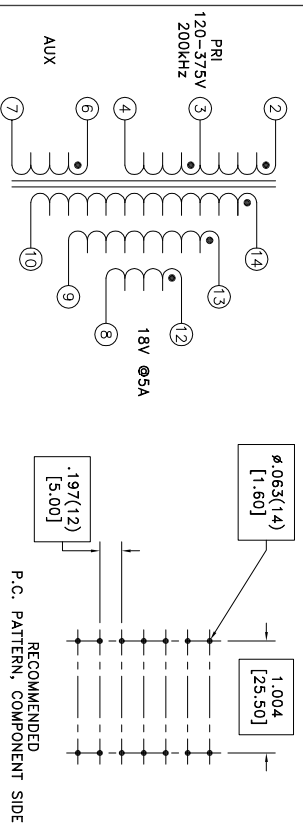
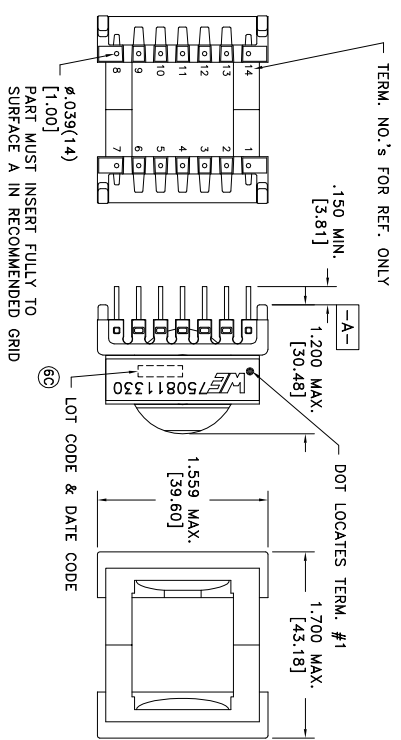

ELECTRICAL SPECIFICATIONS @ 25°C unless otherwise noted:

PARAMETER	TEST CONDITIONS	VALUE
D.C. RESISTANCE	2-4 @20°C	0.15 ohms ±20%
D.C. RESISTANCE	6-7 @20°C	0.0420 ohms max.
D.C. RESISTANCE	8-12 @20°C	0.0250 ohms max.
D.C. RESISTANCE	9-13 @20°C	0.0250 ohms max.
D.C. RESISTANCE	10-14 @20°C	0.0250 ohms max.
INDUCTANCE	2-4 10kHz, 100mVAC, 1s	300uH ±10%
SATURATION CURRENT	20% rolloff from initial	4.0A
LEAKAGE INDUCTANCE	2-4 tie(6+7, 8+9+10+12+13+14), 100kHz, 100mVAC, 1s	3.5uH typ., 6.0uH max.
DIELECTRIC	2-14 tie(4+6, 12+13+14), 4500VAC, 1 second	4500VAC, 1 minute
DIELECTRIC	2-6 1250VAC, 1 second	1000VAC, 1 minute
TURNS RATIO	(2-4):(14-10)	6:1, ±1%
TURNS RATIO	(2-4):(13-9)	6:1, ±1%
TURNS RATIO	(2-4):(12-8)	6:1, ±1%
TURNS RATIO	(2-4):(6-7)	6:1, ±1%
TURNS RATIO	(2-3):(3-4)	1:1, ±1%

GENERAL SPECIFICATIONS:

- OPERATING TEMPERATURE RANGE: -40°C to +125°C including temp rise.
- Designed to comply with the following requirements as defined by IEC61558-2-17:
 - Reinforced insulation for a primary circuit at a working voltage of 400VDC.

Wire insulation & RoHS status not affected by wire color.
Wire insulation color may vary depending on availability.

REV.	DATE	Packaging Specifications	Tolerances unless otherwise specified: Angles: ±1° Fractions: ±1/64 Decimals: ±.005 Footprint: ±.001	DRAWING TITLE	PART NO.
6C	6/14	Method: Tray PKG-0904 www.welsh-electronics.com/midcom	Dimensions in brackets are in millimeters.	TRANSFORMER	750811330
6B	1/11	CONVERSION PLACEMENT			
6A	10/10	SEE REVISION SHEET FOR REVISION LEVEL			

