

TERMINAL NAME: CONTACT POWER CONN					
555928-1					
555928-2					
555485-1	PAD LTR	CRIMP HEIGHT	WIRE SIZE		
556136-1	A	.129 ±.002	10		
556880-2	B	NOT	USED		
	C	.115 ±.002	12		
	D	NOT	USED		
	CRIMP	SIZE	TYPE	RANGE	
	WIRE	.180	F	12-10	
	INSUL	-	-	-	
WIRE STRIP LENGTH	TERM APPL SPEC	FEED	APPL INSTRUCTION	SET UP GAGE	LAYOUT
-	1 14-6034	.730	AI-8040	458637-1	1288

LOC		DIST		REVISIONS			
A	66			DESCRIPTION	DATE	BY	APPRO
		N	ECR-09-010175		5-2009	MY	GB

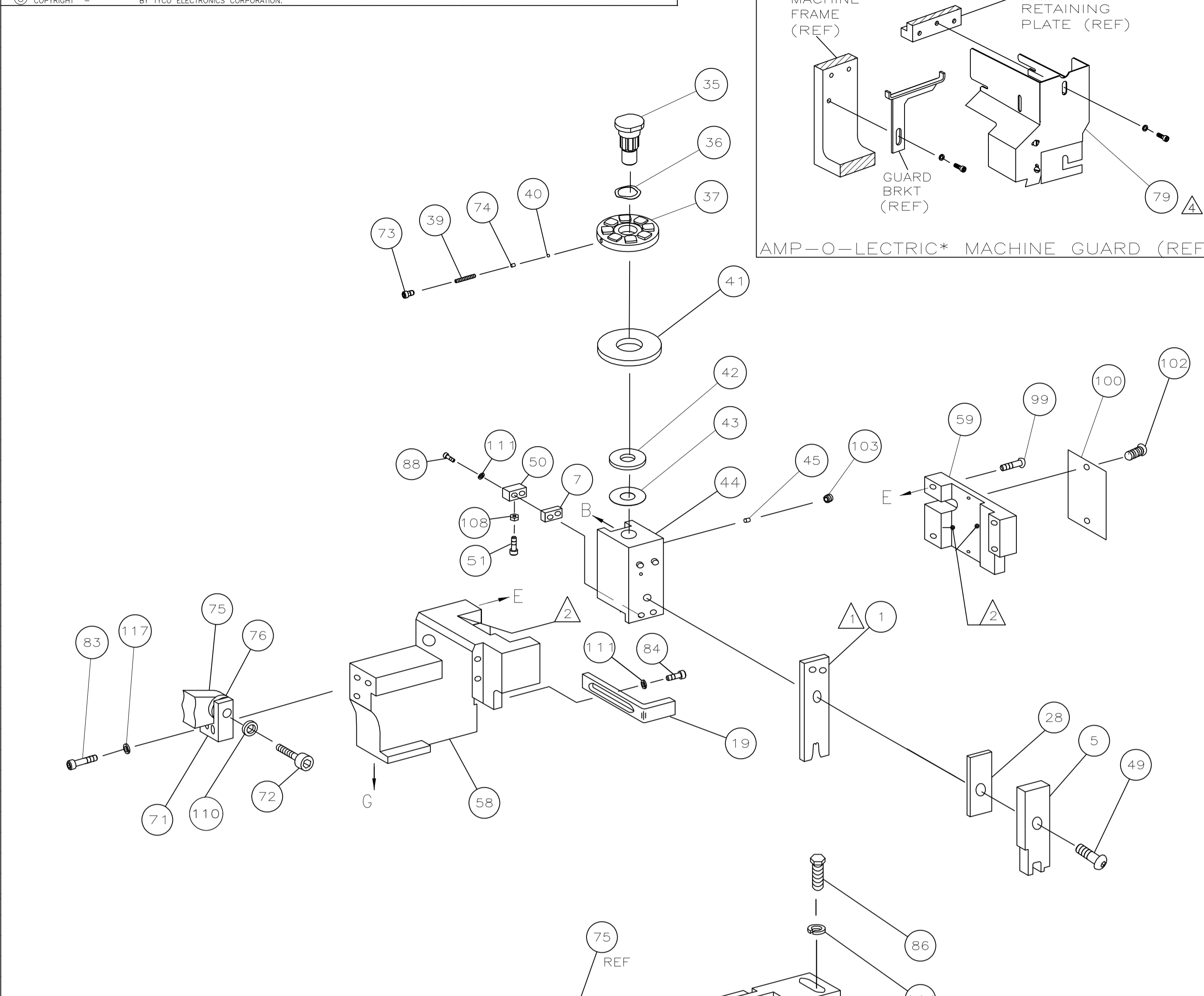

QTY	PART NO	DESCRIPTION	ITEM NO
			129
			128
			127
			126
			125
			124
			123
			122
1	4-21028-0	PIN,SLT SPR(.093φx.75)ST GUIDE PL	121
			120
			119
			118
3	21024-5	WASHER,LOCK(NO.10)ADJ BLOCK	117
			116
			115
2	21024-2	WASHER,LOCK(NO.4)FRONT STRIP GUIDE	114
			113
			112
4	21024-4	WASHER,LOCK(NO.8)STRIPPER	111
1	21024-8	WASHER,LOCK,(3/8) FEED ASSY	110
			109
1	21018-5	NUT, HEX (#6-32)	108
			107
			106
1	22353-8	SCR,SHLD(.187φx.25)DRAG LEVER	105
			104
1	21009-2	SCR,SKT SET(1/4-20x.25)LOC-WEL)RAM	103
2	21017-2	SCR,DRIVE(#2x.19)ID PLATE	102
			101
1	461264-1	PLATE, IDENTIFICATION	100
4	2-21002-9	SCR,BHC(10-32x.75)HOUSING	99
1	22733-8	SCR,BHC(8-32x.38)LOC-WEL)ANVIL	98
			97
3	2-22733-8	SCR,BHC(1/4-20x.62)HOUSING	96
1	2-21002-7	SCR,BHC(10-32x.50)SG ADJ BLOCK	95
6	2-21002-2	SCR,BHC(8-32x.50)SHEAR	94
2	5-21006-6	SCR,SET,(10-32x.75) DRAG	93
			92
			91
			90
			89
			88
2	2-21000-8	SCR,SHC (8-32X .63)	87
2	2-21000-5	SCR,SKT CAP(8-32x.25)DEP-HOLD DOWN	86
1	2-22603-0	SCR,HEX HEAD(8-32x.31)FEED FINGER	85
2	1-21000-3	SCR,SKT CAP(4-40x.25)F STRIP GUIDE	84
1	2-21000-7	SCR,SKT CAP(8-32x.50)STRIPPER	83
2	3-21000-9	SCR,SKT CAP(10-32x1.00)FEED ASSY	82
			81
1	3-21000-4	SCR,SKT CAP(10-32x.38)SG ADJ BL	80
			79
			78
			77
			76
1	371178	BASE MOUNT WASHER	75
1	461065-1	AIR FEED ASSY	74
1	690603-1	SPRING, ASSIST	73
1	23030-1	SCR,SKT CAP(6-32x.25)CP DISC	72
1	3-21001-5	SCR,SHC(3/8x1.00)MT FEED BRKT	71
1	459610-3	MOUNT, FEED BRACKET	70
-3	PART NO	DESCRIPTION	ITEM NO
QTY	PARTS LIST		

QTY	PART NO	DESCRIPTION	ITEM NO
			69
			68
			67
			66
			65
			64
			63
			62
			61
			60
1	454220-1	CAP, HOUSING	59
1	454485-1	HOUSING	58
			57
1	458537-2	PAWL, FEED	56
1	692655-7	AIR FEED VALVE ASSY	55
			54
1	461062-2	FEED FINGER ASSY	53
			52
1	811242-2	BUMPER, HOLDER	51
1	690753-1	SPACER, TONKER	50
1	7-21002-9	BOLT, CRIMPER(5/16-24x1.00)	49
			48
			47
			46
1	690191-1	PLUG, NYLON	45
1	455673-1	RAM	44
1	690125-1	WASHER, LAMINATED	43
1	690124-1	WASHER, RAM	42
1	690223-1	DISC, SPACER	41
1	23241-6	BALL, STEEL	40
1	690170-1	SPRING, COMPRESSION	39
			38
1	9-455829-4	DISC, WIRE	37
1	22480-5	WASHER, SPRING	36
1	690212-1	POST, RAM	35
1	690786-3	SUPPORT, TERMINAL	34
1	455675-1	PLATE, BASE	33
1	690432-3	SCREW, ADJUSTMENT	32
			31
1	455689-1	BLOCK, STRIP GUIDE ADJ	30
1	458144-1	PLATE, STRIP GUIDE	29
1	1-455888-9	SPACER, FRONT SHEAR DEP	28
2	1-22284-0	SPRING, DRAG	27
1	356835-1	LEVER, DRAG RELEASE	26
1	240792-1	DRAG, STOCK	25
1	6-690504-1	GUIDE, STRIP (REAR)	24
1	690438-1	GUIDE, STRIP (FRONT)	23
			22
			21
			20
1	690472-2	STRIPPER	19
			18
			17
			16
			15
			14
			13
1	3-22280-3	SPRING, SHEAR	12
1	690461-7	STOP, SHEAR	11
1	1-690459-0	HOLDER, SHEAR	10
1	1-454276-6	SHEAR, FLOAT (FRONT)	9
1	3-683403-6	ANVIL	8
1	240641-5	SPACER, DEPRESSOR (REAR)	7
			6
1	2-455889-1	DEPRESSOR, SHEAR (FRONT)	5
			4
			3
			2
1	456412-9	CRIMPER, WIRE	1
-3	PART NO	DESCRIPTION	ITEM NO
QTY	PARTS LIST		

- NOTES:
- 1 RECOMMENDED SPARE PARTS.
  - 2 GREASE LIGHTLY.
  - 3 LUBRICATE DAILY USING NO. 20 MACHINE OIL.
  - 4 GUARD MUST BE IN PLACE WHEN OPERATING APPLICATOR IN AMP-O-ELECTRIC MACHINE.

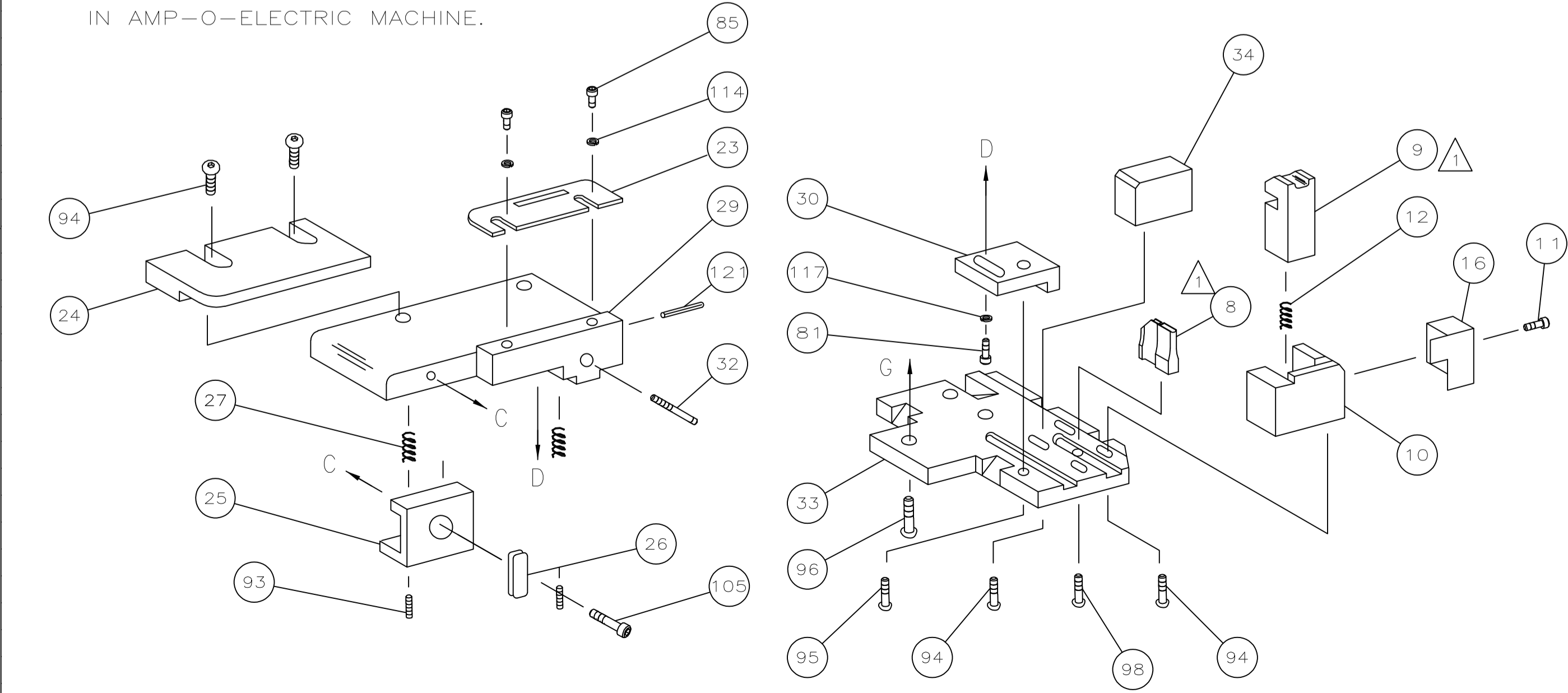

THIS DRAWING IS A CONTROLLED DOCUMENT.

DIMENSIONS: INCHES  
 TOLERANCES UNLESS OTHERWISE SPECIFIED:  
 0 PLC ± .005  
 1 PLC ± .002  
 2 PLC ± .001  
 3 PLC ± .0005  
 4 PLC ± .0002  
 ANGLES ± .001

MATERIAL: - FINISH: -  
 WEIGHT: -  
 CUSTOMER DRAWING: A100779C=567256-3

THIS DRAWING IS A CONTROLLED DOCUMENT. M. YOUNGER 010CT2008 G. RAILLEY 02SEP2008 T. ELBIN 02SEP2008 Tyco Electronics Corporation Harrisburg, PA 17105-3608  
 MINIATURE QUICK CHANGE APPLICATOR SIDE FEED (CONTACT POWER CONN)  
 SCALE: 1:1 SHEET 1 OF 1 REV N