

Mechanical Dimensions: Inches [mm]

Tolerances ± 0.012 [0.3] Unless Otherwise Specified

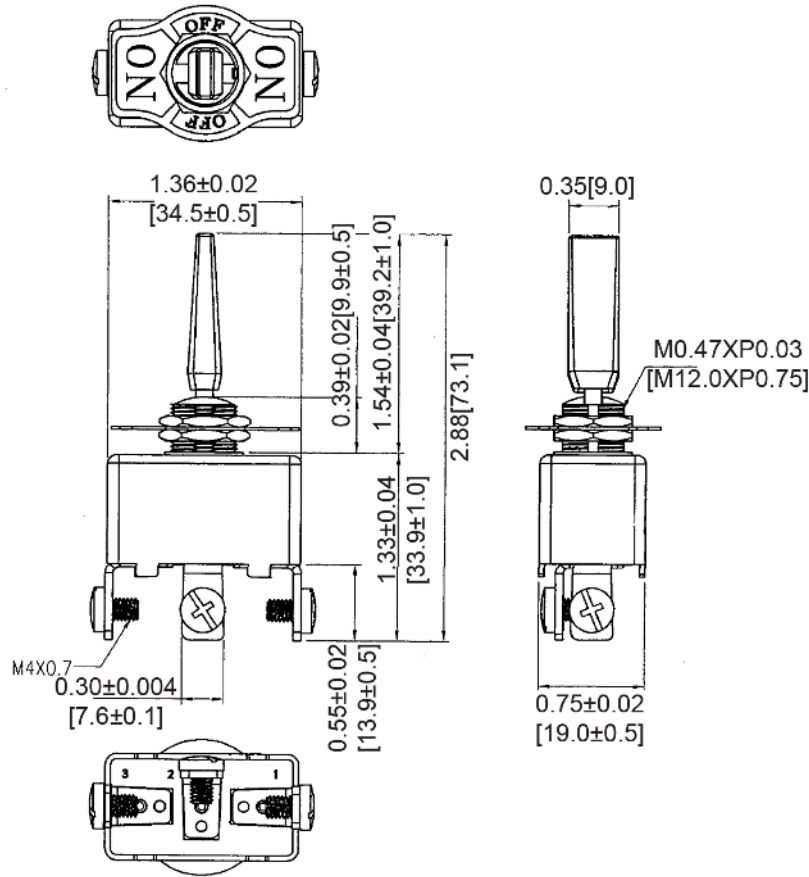

Mounting Hole

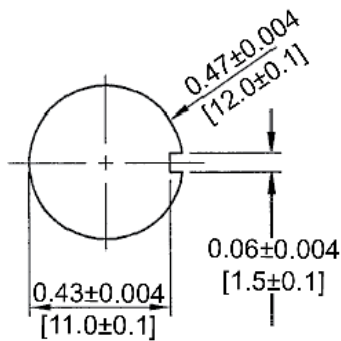

Circuit Diagram

3P SPDT ON-OFF-ON



Electrical Specifications

Rating	50A 12V DC
Contact Resistance	50m ohm Max
Insulation Resistance	DC 500V 100M ohm Min
Dielectric Strength	AC 1500V 1 minute
Operation Temperature	-20°C~85°C

Material Specifications

2 HEX NUT ASSY
1 ON/OFF/ON FACE PLATE ASSY

Rev	Date of issue	Revision Notes	Designed	Approved
A	01-14-2020	Initial Drawing	RC	OF