



100 MHz Crystal Bandpass Filter

Part Number: AM100CR153

Filter Type:	Band Pass
Center Frequency (Fo):	100MHz
3 dB Bandwidth:	$\pm 1.5\text{KHz}$ Min
Insertion Loss:	8.5dB Max.
20 dB Bandwidth:	$\pm 5\text{KHz}$ Min
Ultimate Attenuation and Spurious:	20 dB Min.
Passband Ripple:	1 dB Max.
Impedance:	50 Ohms
Operating Temperature:	0 to +50 deg. C

Outline Drawing:

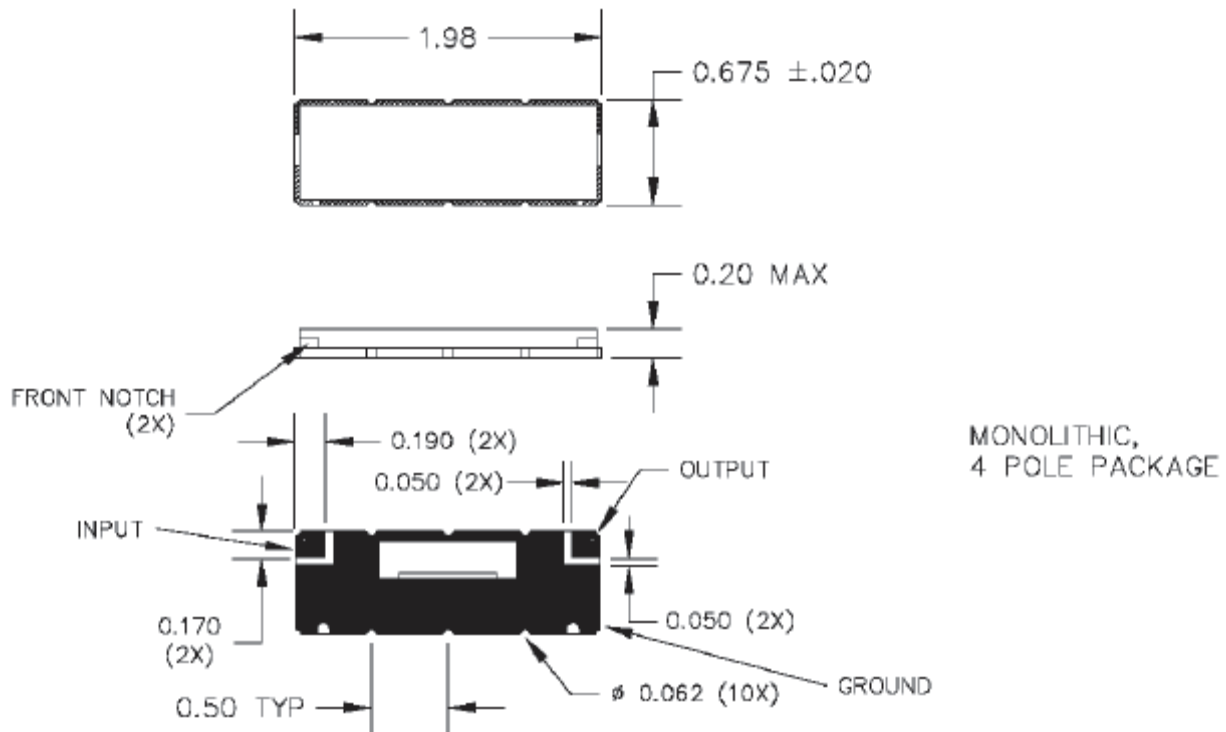



100 MHz Crystal Bandpass Filter

Part Number: AM100CR153

Response Plot:

