

LOC	DIST	REVISIONS		
AJ	16	P	LTR	DESCRIPTION
		L2		REVISED PER ECO-11-005030
			DATE	DWN
			11MAR11	RK
				APVD
				HMR

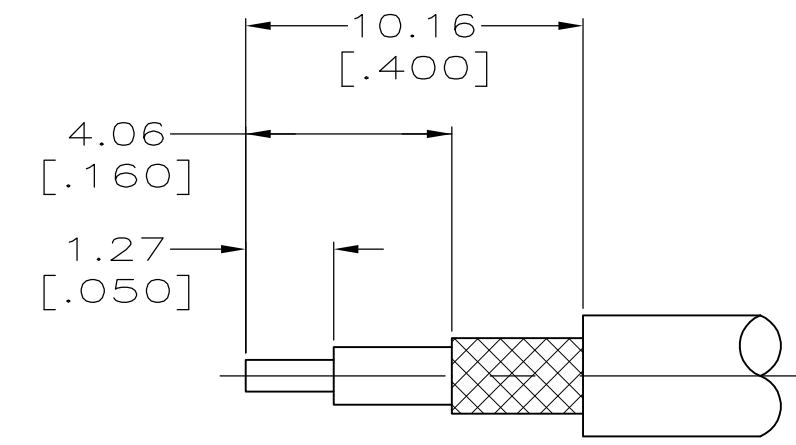
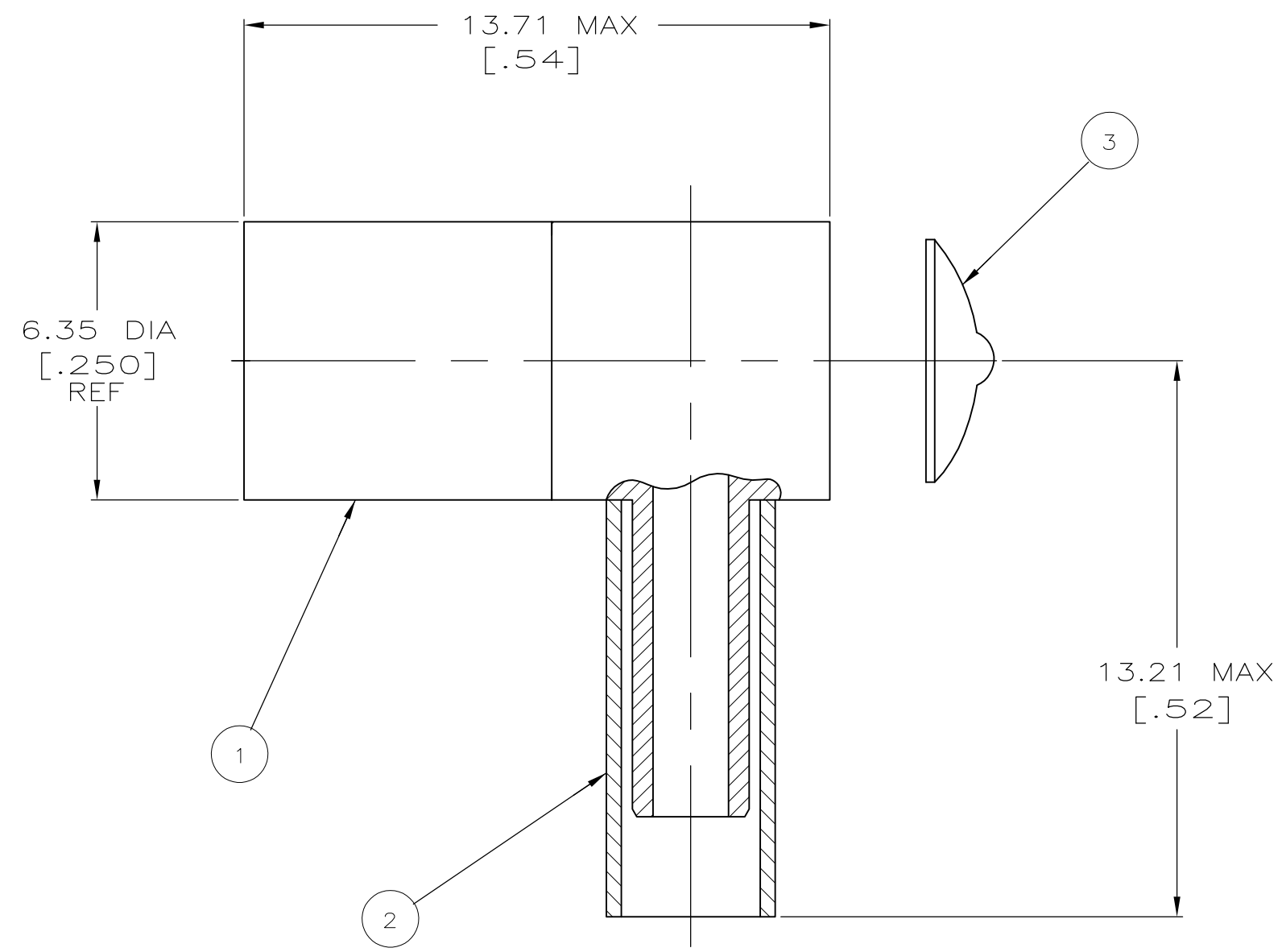

RECOMMENDED STRIP LENGTHS  
SCALE NTS

- 1. INTERFACE PER MIL-C-39012.
- 2. SEE INSTRUCTION SHEET 408-2987-9.
- 3. USES SCREW MACHINED CONTACT.
- 4. OBSOLETE PARTS: OBSOLETE CIS STREAMLINING PER D.RENAUD/D.SINISI

OBSOLETE	C	58483-1	.151	HX4-1637	414013-3	1-413889-4	414364-6	RG 174,188,316(ALL DBL SHIELDED)	3-1-414363-4			
OBSOLETE	C	58483-1	.151	HX4-1637	414013-3	1-413889-4	414364-1	RG 174,188,316(ALL DBL SHIELDED)	1-414363-2			
4	OBSOLETE	C	58483-1	.151	HX4-1637	1-413889-4	414364-1	RG 174,188,316(ALL DBL SHIELDED)	<del>1-414363-1</del>			
OBSOLETE	A	58483-1	.105	HX4-1637	414013-3	1-413889-5	414364-4	RG 178,196	414363-9			
	A	58483-1	.105	HX4-1637	414013-3	1-413889-5	414364-3	RG 178,196	414363-8			
OBSOLETE	C	58483-1	.151	HX4-1637	414013-3	1-413889-4	414364-2	RG 174,188,316(ALL DBL SHIELDED)	414363-6			
	B	58483-1	.128	HX4-1637	414013-3	1-413889-3	414364-2	RG 174,188,316	414363-5			
	C	58483-1	.151	HX4-1637	414013-3	1-413889-4	414364-1	RG 174,188,316(ALL DBL SHIELDED)	414363-4			
	B	58483-1	.128	HX4-1637	414013-3	1-413889-3	414364-1	RG 174,188,316	414363-3			
	POSITION LETTER	AMP DIE SET	HEX SIZE	DANIELS DIE SET	3	END CAP QTY=1	2	FERRULE QTY=1	1	PLUG ASSY QTY=1	CABLE	PART NO
		PRO-CRIMPER FOR BRAID CRIMP	M 22520/5-01 FOR BRAID CRIMP									

TOOLING INFORMATION

THIS DRAWING IS A CONTROLLED DOCUMENT.

DWN	19JUN92	B. MOYER
CHK	25JUN92	J. FLANAGAN
APVD	-	-

STE TE Connectivity

PRODUCT SPEC: PLUG,RTANG CRIMP,HEX CRIMP,SMB

APPLICATION SPEC: -

SIZE: A2 CAGE CODE: 00779 DRAWING NO: 414363

RESTRICTED TO: -

CUSTOMER DRAWING SCALE: 8:1 SHEET: 1 OF 1 REV: L2