

UC1874-1,-2
UC2874-1,-2
UC3874-1,-2

During standby operation, the output capacitor supplies all of the load current requirements. Normal operation returns when the output voltage has drooped by 1%. Reverse current in the inductor is prevented by on-chip circuitry providing additional efficiency improvements. Virtual 100% duty cycle operation is easily attained by the controller even though a bootstrapped high side drive technique is employed.

A low power sleep mode can be invoked through the SS pin. Quiescent supply current in sleep mode is typically less than 50mA. Two UVLO options are available. The

UC3874-1 is designed for logic level MOSFETs and has UVLO turn-on and turn-off thresholds of 4.5V and 4.4V respectively. The UC3874-2 is designed for standard power MOSFETs and has UVLO turn-on and turn-off thresholds of 10V and 9V respectively. A precision 2.5V reference can supply 20mA to external circuitry. An error amplifier with soft start, high bandwidth current amplifier, and a synchronizable oscillator are additional features.

Available packages include 18-pin plastic and ceramic DIP (N, J), 18-pin SOIC (DW), and 20-pin plastic and ceramic leadless chip carriers (Q, L).

ABSOLUTE MAXIMUM RATINGS

Supply Voltage (VCC)	36V
Boost Voltage (BOOT)	50V
OUTPUT Drivers (HDRIVE, LDRIVE) Currents	
(continuous)	±0.25A
(peak)	±1A
VREF Current	Internally Limited
Inputs (VSNS, SS, COMP, CT)	-0.3 to 10V
Inputs (ISNS+, ISNS-)	-0.3 to 20V
Outputs (CAOUT)	-0.3 to 10V
Soft start Sinking Current	1.5mA
Storage Temperature	-65°C to +150°C
Junction Temperature	-65°C to +150°C
Lead Temperature (Soldering, 10 sec.)	+300°C

All currents are positive into, negative out of the specified terminal. All voltages are referenced to GND. Consult Packaging Section of Databook for thermal limitations and considerations of packages.

CONNECTION DIAGRAMS

DIL-18 (TOP VIEW)
J or N, DW Packages

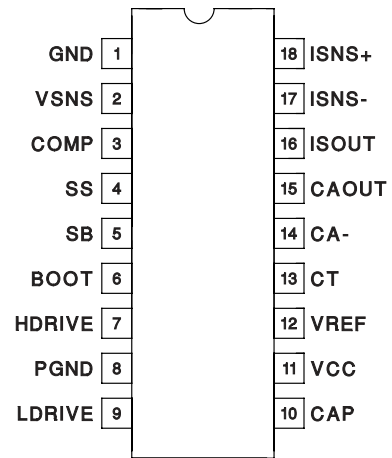

PLCC-20 (TOP VIEW)
Q Package

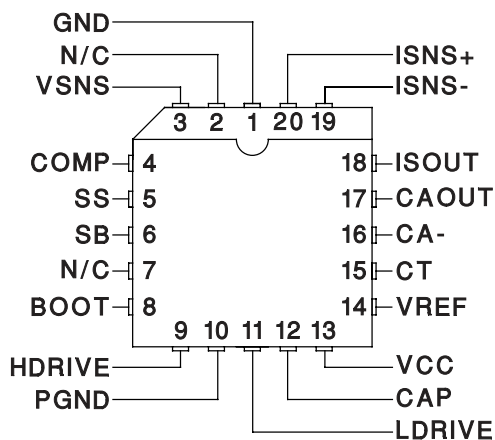

LCC-28 (TOP VIEW)
L Package

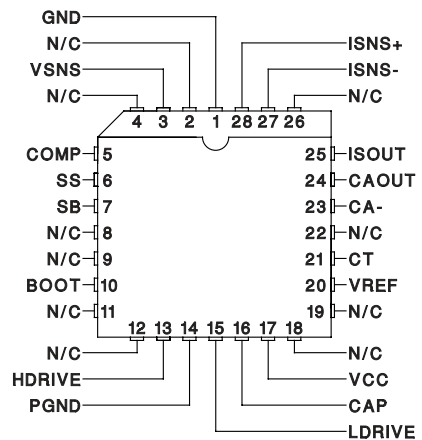

ELECTRICAL CHARACTERISTICS: Unless otherwise stated these specifications apply for TA = -55°C to +125°C for UC1874; TA = -25°C to +85°C for UC2874; 0°C to +70°C for UC3874; VCC = 12V, Ct = 680pF, CCAP = 1μF; CBOOT = 0.1μF; TA = TJ.

PARAMETER	TEST CONDITIONS	MIN	TYP	MAX	UNITS
Overall Section					
Supply Current, Sleep	SOFTSTART = 0V; TA=25°C		30	75	μA
Supply Current, Operating			8.5	12	mA
Supply Current, Standby	UC2874-1, -2, UC3874-1, -2		2.5	3.5	mA
Supply Current, Standby	UC1874-1, -2			5.5	mA
Vcc Turn-on Threshold	UCX874-2		10	10.5	V
	UCX874-1		4.5	4.8	V
Vcc Turn-off Threshold	UCX874-2	8.2	9		V
	UCX874-1	4.1	4.4		V
Voltage Amplifier Section					
Input Voltage	TA = 25°C	1.97	2	2.03	V
VSNS Bias Current		-500	25	500	nA
Transconductance	ICOMP = +10μA to -10μA, UC3874 -1, -2; UC2874-1, -2	400	675	1000	μMho
Transconductance	ICOMP = +5μA to -5μA, UC1874-1,-2	250	675	1250	μMho
VOUT High		2.8	3.1	3.25	V
VOUT Low	SB = VREF			1.85	V
Output Source Current	VOUT = 1V; UC3874-1,-2; UC2874-1,-2	10	35		μA
	VOUT = 1V; UC1874 -1,-2	5	35		μA
Current Amplifier Section					
Input Offset Voltage	VCOMP = 2.5V	-6	0	6	mV
Input Bias Current (SENSE)	VCM = 2.5V	-500		500	nA
Open Loop Gain	VCM = 2.5V, VOUT = 1V to 3.5V	80	110		dB
VOUT High	RCAOUT = 100k to GND, TA = 25°C	3.6	3.7		V
VOUT Low	RCAOUT = 100k to VREF, TA = 25°C		0.7	0.86	V
Output Source Current	VOUT = 0V, TA = 25°C	80	100	120	μA
Common Mode REJ Ratio	VCM = 2V to 3V	70	90		dB
Gain Bandwidth Product	FIN = 100kHz, 10mV p-p	2	3.5		MHz
Reference Section					
Output Voltage	IREF = 0mA, TA = 25°C	2.462	2.5	2.538	V
	IREF = 0mA	2.437	2.5	2.563	V
Load Regulation	IREF = 0mA to 5mA		2	± 15	mV
Line Regulation	VCC = 12V to 24V		2	± 15	mV
Short Circuit Current	VREF = 0V	10	20	25	mA
Oscillator Section					
Initial Accuracy	TA = 25°C	85	100	115	kHz
Voltage Stability	VCC = 12V to 18V		1	1.5	%
Total Variation	Line, Temperature	80		120	kHz
Ramp Amplitude (p-p)	TA = 25°C	2.48	2.7	2.85	V
Ramp Valley Voltage	TA = 25°C	0.86	0.95		V
Sleep/Soft Start/Bootstrap Section					
Sleep Threshold	Measured on SS, TA = 25°C	0.25	0.6	0.8	V
SS Charge Current	VSS = 2.5V	4	6	10	μA
SS Discharge Current	VSS = 2.5V	0.5	0.8		mA

ELECTRICAL CHARACTERISTICS: Unless otherwise stated these specifications apply for $T_A = -55^{\circ}\text{C}$ to $+125^{\circ}\text{C}$ for UC1874; $T_A = -25^{\circ}\text{C}$ to $+85^{\circ}\text{C}$ for UC2874; 0°C to $+70^{\circ}\text{C}$ for UC3874; $V_{CC} = 12\text{V}$, $C_t = 680\text{pF}$, $C_{CAP} = 1\mu\text{F}$; $C_{BOOT} = 0.1\mu\text{F}$; $T_A = T_J$.

PARAMETER	TEST CONDITIONS	MIN	TYP	MAX	UNITS
Sleep/Soft start/Bootstrap Section (continued)					
Bootstrap Regulation Voltage	UCX874-2, Low Driver ON	9.5	10.2	12.5	V
	UCX874-1, Low Driver ON	6	7.5	9	V
Bootstrap Refresh Voltage	UCX874-2, $V_{CAOUT} > V_{CTPEAK}$	7	8	9	V
	UCX874-1, $V_{CAOUT} > V_{CTPEAK}$	2.7	3.5	4	V
High Side Driver Output Section					
Output High Voltage	$I_{OUT} = -50\text{mA}$, $Boot = 23\text{V}$	21	22.2		V
Output Low Voltage	$I_{OUT} = 50\text{mA}$		1	2.2	V
	$I_{OUT} = 10\text{mA}$		300	500	mV
Output Low (UVLO)	$I_{OUT} = 50\text{mA}$, $V_{CC} = 0\text{V}$		0.9	1.5	V
Output Rise Time	$C_{OUT} = 1\text{nF}$		40	160	ns
Output Fall Time	$C_{OUT} = 1\text{nF}$		30	100	ns
Low Side Driver Output Section					
Output High Voltage	$I_{OUT} = -50\text{mA}$, $V_{CAP} = 11\text{V}$	8.8	9.5		V
Output Low Voltage	$I_{OUT} = 50\text{mA}$		1	2.2	V
	$I_{OUT} = 10\text{mA}$		300	500	mV
Output Low (UVLO)	$I_{OUT} = 50\text{mA}$, $V_{CC} = 0\text{V}$		0.9	1.5	V
Output Rise/Fall Time	$C_{LOAD} = 1\text{nF}$		40	160	ns
Output Fall Time	$C_{OUT} = 1\text{nF}$		30	100	ns
X10 Amplifier Section					
Gain	$V_{ISNS} \pm V_{ISNS} = 20\text{mV}$ to 80mV	9.2	9.8	10.4	V/V
Slew Rate Rising	$T_A = 25^{\circ}\text{C}$	1	1.4		V/ μs
Slew Rate Falling	$T_A = 25^{\circ}\text{C}$	2	3.5		V/ μs
Input Resistance	$T_A = 25^{\circ}\text{C}$	60	100	165	k Ω

PIN DESCRIPTIONS

BOOT: This pin provides the high side rail for the HDRIVE output. An external capacitor (C_{BST}) is connected between this pin and the drain of the external low side MOSFET. When the low side MOSFET is conducting C_{bst} is charged to 11V via an external diode tied to CAP. When the low side MOSFET turns off and the high side MOSFET turns on, the C_{bst} bootstraps itself up with the source of high side MOSFET, ultimately providing a 10V V_{gs} for the upper MOSFET. Since this 10V is referenced to the source of the high side N-channel MOSFET, the actual voltage on BOOT and HDRIVE is approximately 10V above V_{CC} while the high side MOSFET is conducting. The voltage on BOOT is continuously monitored during low input voltage conditions when the duty cycle equals approximately 100% to insure that a sufficient gate drive level is being supplied by the UC3874. If the voltage on BOOT falls below 8V (UC3874-2) or 3.5V (UC3874-1), the IC forces

the low side driver to cycle itself on for the few cycles required to replenish C_{BST} . In this way, virtual 100% duty cycle operation is provided.

CA-: This is the inverting input to the current amplifier. Connect a series resistor and capacitor between this pin and CAOUT to set the current loop compensation. An input resistor between this pin and ISOUT provides the inductor current sense signal to the amplifier and also sets the high frequency gain of the amplifier. The common mode operating range for this input is between GND and 4V. The normal range during operation is between 2V and 3V.

CAOUT: This is the output of the wide bandwidth current amplifier and one of the inputs to the PWM duty cycle comparator. The output signal generated by this amplifier commands the PWM to force the correct duty cycle to maintain output voltage in regulation. The output can swing from 0.1V to 4V.

CAP: A capacitor is normally connected between this pin and GND providing bypass for the internal 11V regulator. Charge is transferred from this capacitor to CBST via an external diode when the low side MOSFET is conducting. If $VCC \leq 10V$ logic level MOSFETs are generally specified. CAP should then be shorted to VCC in conjunction with a low VF Schottky to BOOT to maximize the gate drive amplitude. This technique provides adequate gate drive signal amplitudes with VCC as low as 4.5V. For high input voltage applications, a simple external shunt zener regulator circuit can be connected to CAP, thereby offloading power dissipation requirements from the IC to an external transistor.

COMP: This is the output of the voltage amplifier. It provides the current command signal to the current amplifier. The voltage is clamped to approximately 3.2V.

CT: A capacitor from CT to GND sets the PWM oscillator frequency according to the following equation:

$$F = \frac{1}{14250 \cdot CT}$$

Use a high quality ceramic capacitor with low ESL and ESR for best results. A minimum CT value of 220pF insures good accuracy and less susceptibility to circuit layout parasitics. The oscillator and PWM are designed to provide practical operation to 300kHz.

GND: All voltages are measured with respect to this pin. All bypass capacitors and timing components except those listed under the PGND pin description should be connected to this pin. Component leads should be as short and direct as possible.

HDRIVE, LDRIVE: The outputs of the PWM are totem pole MOSFET gate drivers on the HDRIVE and LDRIVE pins. The outputs can sink approximately 1A and source 500mA. This characteristic optimizes the switching transitions by providing a controlled dV/dT at turn-on and a lower impedance at turn-off. These are complementary outputs with a typical deadtime of 200ns. Internal circuitry prevents the possibility of simultaneous conduction of the output MOSFETs (shoot through). HDRIVE is the high side bootstrapped output. Its upper power supply rail is the BOOT pin which means that its output will fly approximately 10V above VCC when the upper side of the totem pole output is conducting. The power supply rail for LDRIVE is CAP. As a result the Vgs of both gates are regulated to approximately 10V if VCC is >11V. A series resistor between these pins and the MOSFET gates of at least 10 ohms can be used to control ringing. Additionally, a low VF Schottky diode should be connected between these pins and GND to prevent substrate conduction and possible erratic operation.

ISNS-: This is the inverting input to the X10 instrumentation amplifier. The common mode input range for this pin extends from GND to VCC. A low value resistor in series with the output inductor is connected between this pin and ISNS+ to develop the current sense signal.

ISNS+: This is the non-inverting input to the X10 instrumentation amplifier. The common mode input range for this pin extends from GND to VCC.

ISOUT: This is the output of the X10 instrumentation amplifier. The output voltage on this pin is level shifted 2V above GND, such that if a 100mV differential input is applied across ISNS+ and ISNS-, the output will be 3V.

PGND: This is the high current ground for the IC. The MOSFET driver transistors are referenced to this ground. For best performance an external star ground connection should be made between this pin, the source of the low side MOSFET, the capacitor on CAP, the anodes of any external Schottky clamp diodes and the output filter capacitor. As with all high frequency layouts, a ground plane and short leads are highly recommended.

SB: The voltage on SB sets the output current level at which standby mode is initiated. A voltage level from 0V to 1V programs the threshold from 50% to 0% of full load current. Full load current corresponds to a 100mV differential signal across the ISNS inputs. Since this is a high impedance input, a voltage divider derived from VREF may be used to program this level. Another possible use is to actively control this level with external circuitry to adaptively control converter efficiency. Tying SB to VREF disables standby mode operation.

SS: A capacitor from this pin to GND in conjunction with an internal 10mA current source provides a soft start function for the IC. The voltage level on SS clamps the output of the voltage amplifier through an internal buffer, thus providing a controlled startup. The SS time is approximately:

$$\frac{C_{SS} \cdot \frac{V_O}{V_{IN}} \cdot 3V}{10 \mu A}$$

Once the device has completed its soft start cycle, a low power sleep mode can be invoked by pulling SS below 0.5V typically. In sleep mode, all of the device functions are disabled except for those which are required to bring the device out of sleep mode when SS is released. Typical sleep mode supply current is less than 50mA.

VCC: Positive supply rail for the IC. Bypass this pin to GND with a 1mF low ESL/ESR ceramic capacitor. The maximum voltage for VCC is 36V. The turn on voltage level on VCC is 4.5V with 100mV of hysteresis for the UC3874-1 and 10V with 1V of hysteresis for the UC3874-2.

VREF: VREF is the output of the precision reference. The output is capable of supplying 20mA to peripheral circuitry and is internally short circuit current limited. VREF is disabled and low whenever VCC is below the UVLO threshold, and when SS is pulled below 0.5V. A VREF “good” comparator senses VREF and disables the PWM stage until VREF has attained approximately 90%

of its nominal value. Bypass VREF to GND with a 0.1mF ceramic capacitor for best performance.

VSNS: This pin is the inverting input of the voltage amplifier and serves as the output voltage feedback point for the synchronous regulator. It senses the output voltage through a voltage divider which produces a nominal 2.0V.

APPLICATION DIAGRAM

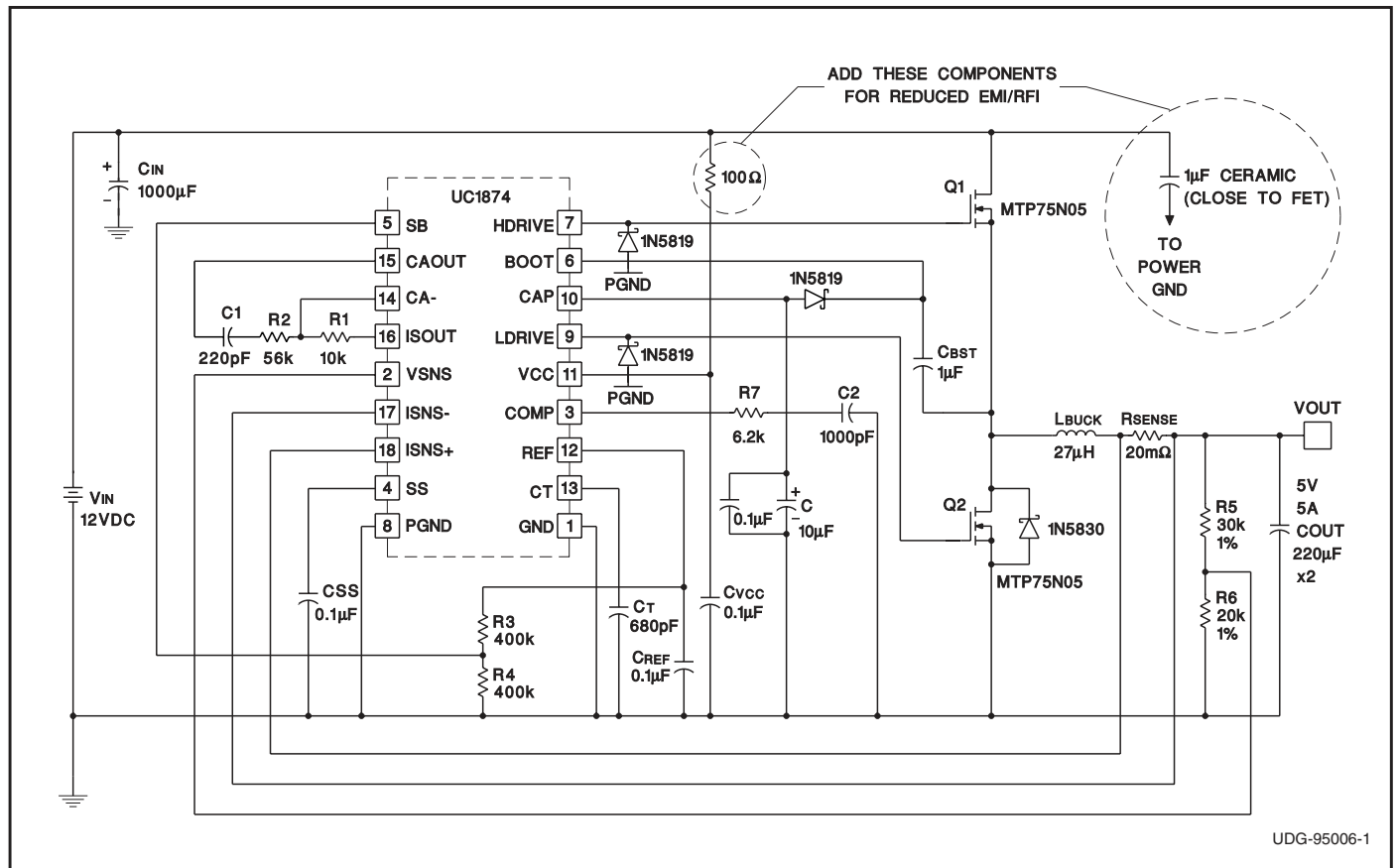

OPERATION: Refer to 5V, 25W Application Schematic

The UC3874 employs a fixed frequency average current mode control buck topology to convert a higher battery voltage down to a tightly regulated output voltage. Special design techniques allow this bipolar IC to deliver exceptional performance while consuming approximately 6mA of supply current over an input voltage range of 4.5 to 35 volts. Fixed frequency operation allows synchronization to an existing system clock, and easier filtering. Average current mode control provides inherent slope compensation and accurate short circuit current limiting. An additional benefit is its ability to maintain a constant regulator gain regardless of whether the inductor current is continuous or discontinuous.

The output inductor current is sensed by an external low value shunt resistor (Rsense). This signal at full load current should be no larger than 100mV in order to minimize sensing losses. The differential voltage across Rsense is amplified by the internal X10 instrumentation amplifier. The common mode input range for this amplifier extends from GND to VCC in order to maintain accurate current sensing under normal conditions as well as abnormal conditions such as output short circuit and low drop out (LDO) modes. The output of the X10 instrumentation amplifier is applied to the inverting input of the current amplifier through an external resistor. The converter's output voltage feedback is applied to the

VSNS pin through an external voltage divider. The difference between the voltage at VSNS and the internal reference level at the non-inverting input is amplified by the voltage amplifier and applied to the non-inverting input of the current amplifier. This instantaneous reference level forms the current command input for the average current control loop. The average current amplifier develops the duty cycle command signal by integrating the current feedback signal with respect to the instantaneous current command input. This output is compared to the fixed high amplitude oscillator ramp waveform at the inputs of the PWM comparator to develop duty cycle information for the PWM drive. The large amplitude oscillator ramp provides both high noise margin and built-in slope compensation in average current mode control methodology. The fixed frequency oscillator is programmed with a single external capacitor connected between CT and GND, and is capable of switching frequencies up to 300kHz. The UC3874 can be synchronized to an external clock by capacitively coupling the signal to the junction of the capacitor at CT and a low value resistor tied to GND. Refer to Application Note U-111.

The PWM drive signal is applied to the complementary output driver stages. Since the high side switch is an N-channel MOSFET, a means for driving its gate above VCC is required. This is accomplished via the internal 11V regulator and an external capacitor (CBST). CBST is charged through an external diode to VCC or CAP when the low side MOSFET is on. The charging level on Cbst is internally regulated to 11V minus an external diode drop by the UC3874 as long as VCC is above 11V. When the low side MOSFET turns off, CBST is applied across the gate to the source of the upper MOSFET allowing it to begin turn-on. As the upper MOSFET turns on, it lifts or bootstraps the low end of CBST, along with its source. Shortly thereafter, the source voltage level is reduced by $R_{DS(on)} \cdot I_{load}$ below VCC. When $V_{CC} < 10V$, V_{gs} for the high side MOSFET is approximately equal to VCC. If $V_{CC} < 8V$, logic level MOSFETs are recommended. In these applications, CAP should be shorted to VCC and an external Schottky diode is connected between CAP/VCC and BOOT. For low battery applications, a synchronous regulator must be capable of LDO or 100% duty cycle operation. The UC3874 includes circuitry to insure that this mode of operation is possible even though it uses a bootstrapped drive technique for the high side MOSFET. During commanded 100% duty cycle operation, the UC3874 monitors the V_{gs} drive signal applied to the high side MOSFET, and automatically provides complementary pulses to refresh the bootstrap capacitor when this voltage falls below a set threshold. In this way, near 100% duty cycle operation is possible, with

effective duty cycle dependent only upon the value of CBST.

High efficiency is obtained primarily by the low side MOSFET which replaces the Schottky diode in the standard buck configuration. Its low $R_{ds(on)}$ produces a much lower voltage drop than a low VF Schottky diode. As output voltages get lower, these improvements become more evident. Additional efficiency improvements at light regulator load currents are obtained by automatic switchover to standby mode. In standby mode, the UC3874 disables its MOSFET drivers and oscillator saving both quiescent supply current consumption and more importantly MOSFET gate drive charge current. Standby mode is initiated when the output inductor current has dropped to a user programmable fraction of the designed full load current. Programmability is easily attained by setting the SB pin to a voltage level between 0V and 1V, which corresponds to 50% to 0% of the peak load current. In this manner, the user can accurately determine when standby mode is initiated, giving the flexibility to directly shape the efficiency vs. load curve. In standby mode, all output current requirements are handled by the output capacitor. Since the output capacitor isn't being refreshed by the PWM converter, the output voltage will decay at a rate determined by the load current and the output capacitor value:

$$\frac{dV}{dT} = \frac{I_{LOAD}}{C_{OUT}}$$

Normal operation returns when the output voltage has decayed by approximately 1% from its nominal value. Standby operation can be easily disabled by connecting the SB pin directly to VREF. Another efficiency consideration is the possibility of reverse current in the output inductor. For a non-synchronous regulator this isn't a problem since the diode will block reverse current, allowing discontinuous inductor current operation at light loads. Since the synchronous regulator replaces the diode with a switch, reverse current can and will flow if the low side switch is on when the inductor is depleted. The UC3874 includes circuitry to prevent reverse current from flowing in the inductor by disabling the low side gate drive signal during discontinuous mode operation. This increases efficiency by eliminating unnecessary I^2R losses in the MOSFET and the inductor.

Soft start is recommended for Buck converters to reduce stress on the power components during startup, and to reduce overshoot of the output voltage. This improves reliability. The UC3874 includes a user programmable soft start pin to implement this feature. An internal 10mA current source charges the external soft start capacitor which provides a clamp at the output of the voltage

amplifier. An ultra low power sleep mode is also invoked from the SS pin. A voltage level below 0.5V on this pin reduces total standby current to less than 50mA. Short circuit protection is inherent to the average current mode technique with proper compensation of the current amplifier. To prevent operation of the MOSFETs with an inadequate drive signal, an undervoltage lockout circuit suppresses the output drivers until the input supply

voltage is sufficiently high enough for proper operation. The UC3874-1 is intended for applications with logic level MOSFETs and its VCC turn-on and turn-off thresholds are 4.5V/4.4V respectively. The UC3874-2 is intended for applications with standard MOSFETs and has UVLO turn-on and turn-off thresholds of 10V and 9V respectively. The precision 2.5V reference can provide 20mA to power external circuitry. The reference output is disabled during UVLO and sleep modes.

ORDERING INFORMATION

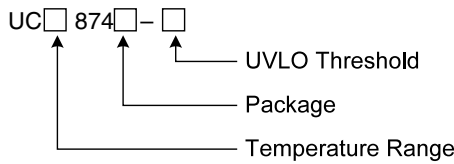

UVLO Turn On/Off Threshold	Package	Temperature Range
1: 4.5V/4.4V	J: Ceramic DIL-18	1: -55°C to +125°C
2: 10V/9V	N: Plastic DIL-18	2: -40°C to +85°C
	DW: SOIC-18	3: 0°C to +70°C

TYPICAL PERFORMANCE INFORMATION

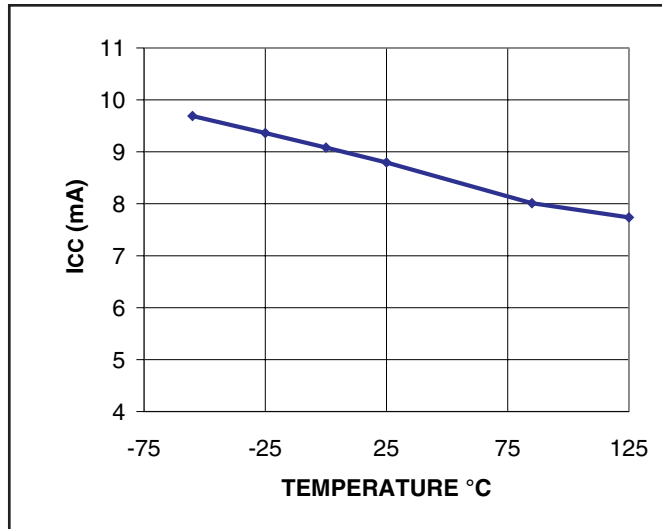

Figure 1. Supply Current

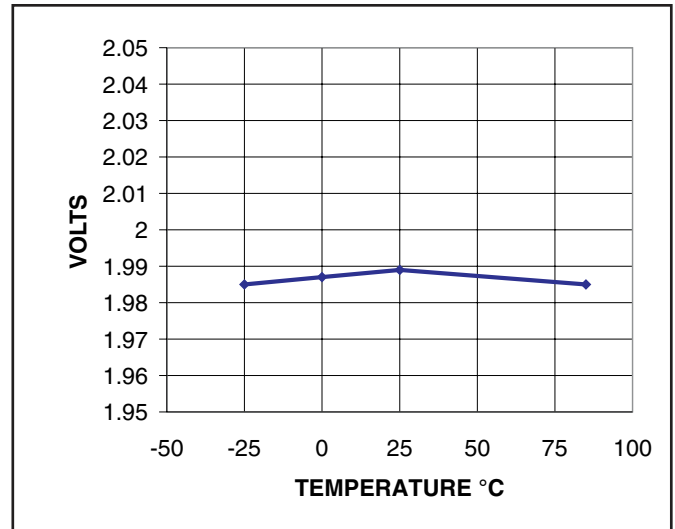

Figure 2. VAMP Input Voltage

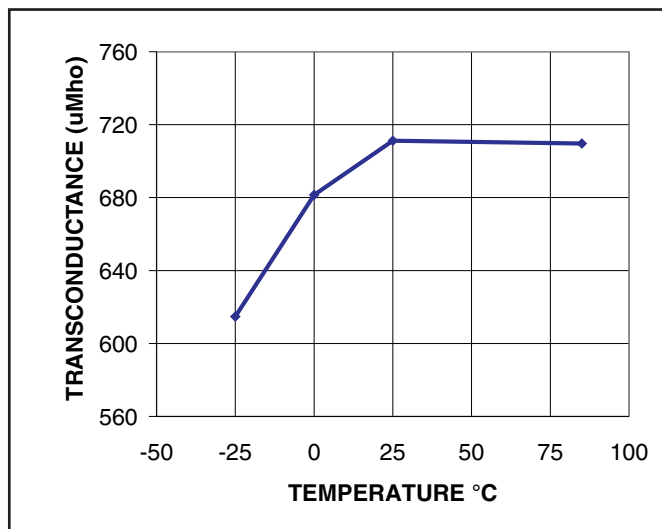

Figure 3. Volt Amp GM (IOUT = 10 A)

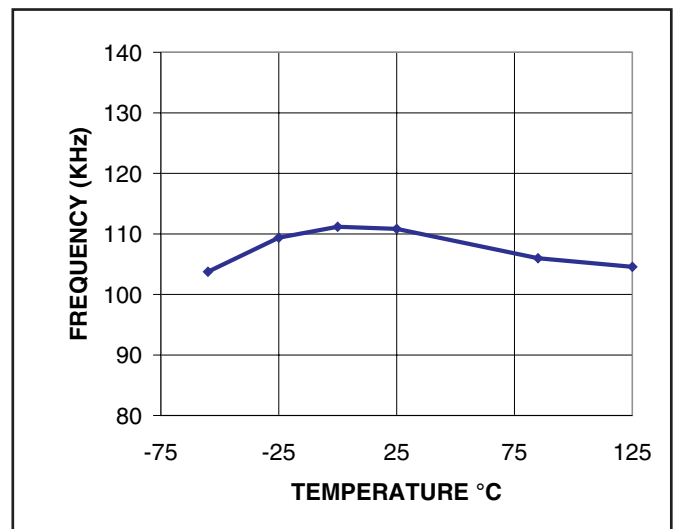

Figure 4. Oscillator Frequency vs. Temperature (CT = 680pF)

PERFORMANCE INFORMATION (continued)

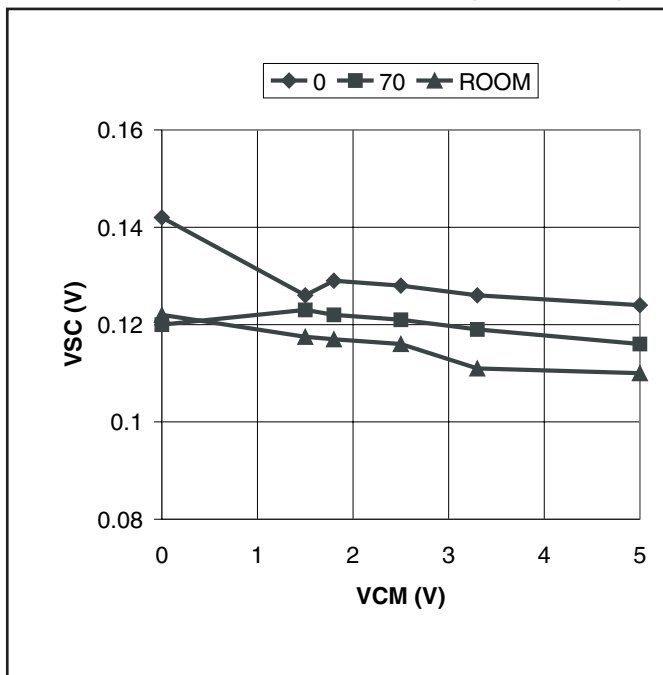

Figure 5. Short Circuit Limit Voltage Reflected to Input of Current Amp vs. Current Amp Common Mode Voltage

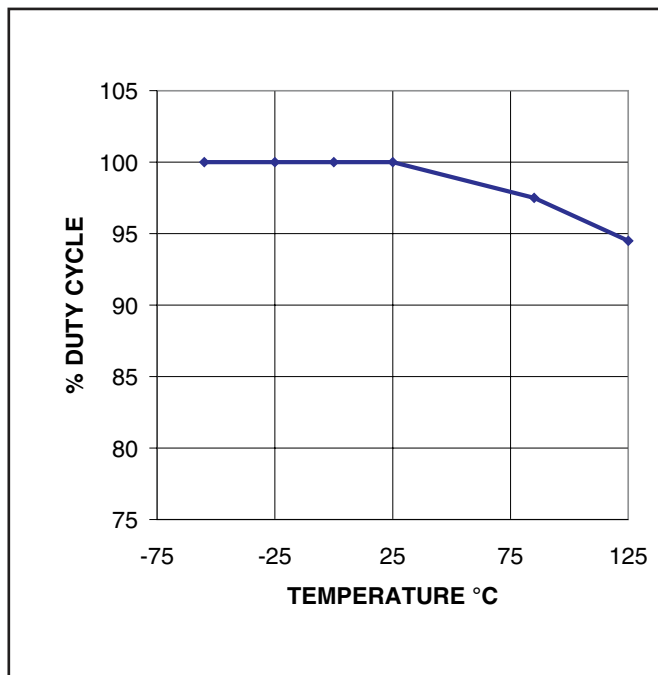

Figure 6. High Drive Maximum Duty Cycle (UC1874-1,-2)

PACKAGING INFORMATION

Orderable Device	Status ⁽¹⁾	Package Type	Package Drawing	Pins	Package Qty	Eco Plan ⁽²⁾	Lead/Ball Finish	MSL Peak Temp ⁽³⁾
UC2874DW-1	ACTIVE	SOIC	DW	18	40	Green (RoHS & no Sb/Br)	CU NIPDAU	Level-2-260C-1 YEAR
UC2874DW-1G4	ACTIVE	SOIC	DW	18	40	Green (RoHS & no Sb/Br)	CU NIPDAU	Level-2-260C-1 YEAR
UC2874DW-2	ACTIVE	SOIC	DW	18	40	Green (RoHS & no Sb/Br)	CU NIPDAU	Level-2-260C-1 YEAR
UC2874DW-2G4	ACTIVE	SOIC	DW	18	40	Green (RoHS & no Sb/Br)	CU NIPDAU	Level-2-260C-1 YEAR
UC2874DWTR-2	ACTIVE	SOIC	DW	18		TBD	Call TI	Call TI
UC2874DWTR-2G4	ACTIVE	SOIC	DW	18		TBD	Call TI	Call TI
UC2874N-1	ACTIVE	PDIP	N	18	20	Green (RoHS & no Sb/Br)	CU NIPDAU	N / A for Pkg Type
UC2874N-1G4	ACTIVE	PDIP	N	18	20	Green (RoHS & no Sb/Br)	CU NIPDAU	N / A for Pkg Type
UC2874N-2	ACTIVE	PDIP	N	18	20	Green (RoHS & no Sb/Br)	CU NIPDAU	N / A for Pkg Type
UC2874N-2G4	ACTIVE	PDIP	N	18	20	Green (RoHS & no Sb/Br)	CU NIPDAU	N / A for Pkg Type
UC2874Q-1	NRND	PLCC	FN	20		TBD	Call TI	Call TI
UC2874Q-2	NRND	PLCC	FN	20		TBD	Call TI	Call TI
UC3874DW-1	ACTIVE	SOIC	DW	18	40	Green (RoHS & no Sb/Br)	CU NIPDAU	Level-2-260C-1 YEAR
UC3874DW-1G4	ACTIVE	SOIC	DW	18	40	Green (RoHS & no Sb/Br)	CU NIPDAU	Level-2-260C-1 YEAR
UC3874DW-2	ACTIVE	SOIC	DW	18	40	Green (RoHS & no Sb/Br)	CU NIPDAU	Level-2-260C-1 YEAR
UC3874DW-2G4	ACTIVE	SOIC	DW	18	40	Green (RoHS & no Sb/Br)	CU NIPDAU	Level-2-260C-1 YEAR
UC3874DWTR-1	ACTIVE	SOIC	DW	18		TBD	Call TI	Call TI
UC3874DWTR-1G4	ACTIVE	SOIC	DW	18		TBD	Call TI	Call TI
UC3874N-1	ACTIVE	PDIP	N	18	20	Green (RoHS & no Sb/Br)	CU NIPDAU	N / A for Pkg Type
UC3874N-1G4	ACTIVE	PDIP	N	18	20	Green (RoHS & no Sb/Br)	CU NIPDAU	N / A for Pkg Type
UC3874N-2	ACTIVE	PDIP	N	18	20	Green (RoHS & no Sb/Br)	CU NIPDAU	N / A for Pkg Type
UC3874N-2G4	ACTIVE	PDIP	N	18	20	Green (RoHS & no Sb/Br)	CU NIPDAU	N / A for Pkg Type

⁽¹⁾ The marketing status values are defined as follows:

ACTIVE: Product device recommended for new designs.

LIFEBUY: TI has announced that the device will be discontinued, and a lifetime-buy period is in effect.

NRND: Not recommended for new designs. Device is in production to support existing customers, but TI does not recommend using this part in a new design.

PREVIEW: Device has been announced but is not in production. Samples may or may not be available.

OBSOLETE: TI has discontinued the production of the device.

⁽²⁾ Eco Plan - The planned eco-friendly classification: Pb-Free (RoHS), Pb-Free (RoHS Exempt), or Green (RoHS & no Sb/Br) - please check <http://www.ti.com/productcontent> for the latest availability information and additional product content details.

TBD: The Pb-Free/Green conversion plan has not been defined.

Pb-Free (RoHS): TI's terms "Lead-Free" or "Pb-Free" mean semiconductor products that are compatible with the current RoHS requirements for all 6 substances, including the requirement that lead not exceed 0.1% by weight in homogeneous materials. Where designed to be soldered at high temperatures, TI Pb-Free products are suitable for use in specified lead-free processes.

Pb-Free (RoHS Exempt): This component has a RoHS exemption for either 1) lead-based flip-chip solder bumps used between the die and package, or 2) lead-based die adhesive used between the die and leadframe. The component is otherwise considered Pb-Free (RoHS compatible) as defined above.

Green (RoHS & no Sb/Br): TI defines "Green" to mean Pb-Free (RoHS compatible), and free of Bromine (Br) and Antimony (Sb) based flame retardants (Br or Sb do not exceed 0.1% by weight in homogeneous material)

⁽³⁾ MSL, Peak Temp. -- The Moisture Sensitivity Level rating according to the JEDEC industry standard classifications, and peak solder temperature.

Important Information and Disclaimer:The information provided on this page represents TI's knowledge and belief as of the date that it is provided. TI bases its knowledge and belief on information provided by third parties, and makes no representation or warranty as to the accuracy of such information. Efforts are underway to better integrate information from third parties. TI has taken and continues to take reasonable steps to provide representative and accurate information but may not have conducted destructive testing or chemical analysis on incoming materials and chemicals. TI and TI suppliers consider certain information to be proprietary, and thus CAS numbers and other limited information may not be available for release.

In no event shall TI's liability arising out of such information exceed the total purchase price of the TI part(s) at issue in this document sold by TI to Customer on an annual basis.

IMPORTANT NOTICE

Texas Instruments Incorporated and its subsidiaries (TI) reserve the right to make corrections, modifications, enhancements, improvements, and other changes to its products and services at any time and to discontinue any product or service without notice. Customers should obtain the latest relevant information before placing orders and should verify that such information is current and complete. All products are sold subject to TI's terms and conditions of sale supplied at the time of order acknowledgment.

TI warrants performance of its hardware products to the specifications applicable at the time of sale in accordance with TI's standard warranty. Testing and other quality control techniques are used to the extent TI deems necessary to support this warranty. Except where mandated by government requirements, testing of all parameters of each product is not necessarily performed.

TI assumes no liability for applications assistance or customer product design. Customers are responsible for their products and applications using TI components. To minimize the risks associated with customer products and applications, customers should provide adequate design and operating safeguards.

TI does not warrant or represent that any license, either express or implied, is granted under any TI patent right, copyright, mask work right, or other TI intellectual property right relating to any combination, machine, or process in which TI products or services are used. Information published by TI regarding third-party products or services does not constitute a license from TI to use such products or services or a warranty or endorsement thereof. Use of such information may require a license from a third party under the patents or other intellectual property of the third party, or a license from TI under the patents or other intellectual property of TI.

Reproduction of TI information in TI data books or data sheets is permissible only if reproduction is without alteration and is accompanied by all associated warranties, conditions, limitations, and notices. Reproduction of this information with alteration is an unfair and deceptive business practice. TI is not responsible or liable for such altered documentation. Information of third parties may be subject to additional restrictions.

Resale of TI products or services with statements different from or beyond the parameters stated by TI for that product or service voids all express and any implied warranties for the associated TI product or service and is an unfair and deceptive business practice. TI is not responsible or liable for any such statements.

TI products are not authorized for use in safety-critical applications (such as life support) where a failure of the TI product would reasonably be expected to cause severe personal injury or death, unless officers of the parties have executed an agreement specifically governing such use. Buyers represent that they have all necessary expertise in the safety and regulatory ramifications of their applications, and acknowledge and agree that they are solely responsible for all legal, regulatory and safety-related requirements concerning their products and any use of TI products in such safety-critical applications, notwithstanding any applications-related information or support that may be provided by TI. Further, Buyers must fully indemnify TI and its representatives against any damages arising out of the use of TI products in such safety-critical applications.

TI products are neither designed nor intended for use in military/aerospace applications or environments unless the TI products are specifically designated by TI as military-grade or "enhanced plastic." Only products designated by TI as military-grade meet military specifications. Buyers acknowledge and agree that any such use of TI products which TI has not designated as military-grade is solely at the Buyer's risk, and that they are solely responsible for compliance with all legal and regulatory requirements in connection with such use.

TI products are neither designed nor intended for use in automotive applications or environments unless the specific TI products are designated by TI as compliant with ISO/TS 16949 requirements. Buyers acknowledge and agree that, if they use any non-designated products in automotive applications, TI will not be responsible for any failure to meet such requirements.

Following are URLs where you can obtain information on other Texas Instruments products and application solutions:

Products

Amplifiers	amplifier.ti.com
Data Converters	dataconverter.ti.com
DLP® Products	www.dlp.com
DSP	dsp.ti.com
Clocks and Timers	www.ti.com/clocks
Interface	interface.ti.com
Logic	logic.ti.com
Power Mgmt	power.ti.com
Microcontrollers	microcontroller.ti.com
RFID	www.ti-rfid.com
RF/IF and ZigBee® Solutions	www.ti.com/lprf

Applications

Audio	www.ti.com/audio
Automotive	www.ti.com/automotive
Broadband	www.ti.com/broadband
Digital Control	www.ti.com/digitalcontrol
Medical	www.ti.com/medical
Military	www.ti.com/military
Optical Networking	www.ti.com/opticalnetwork
Security	www.ti.com/security
Telephony	www.ti.com/telephony
Video & Imaging	www.ti.com/video
Wireless	www.ti.com/wireless

Mailing Address: Texas Instruments, Post Office Box 655303, Dallas, Texas 75265
Copyright © 2009, Texas Instruments Incorporated