

THIS DRAWING IS UNPUBLISHED. RELEASED FOR PUBLICATION 20
 © COPYRIGHT 20 BY - ALL RIGHTS RESERVED.

LOC	DIST	REVISIONS			
P	LTR	DESCRIPTION	DATE	DWN	APVD
DY	-	B2	REVISED PER ECR-12-021394	12DEC12	IT SY

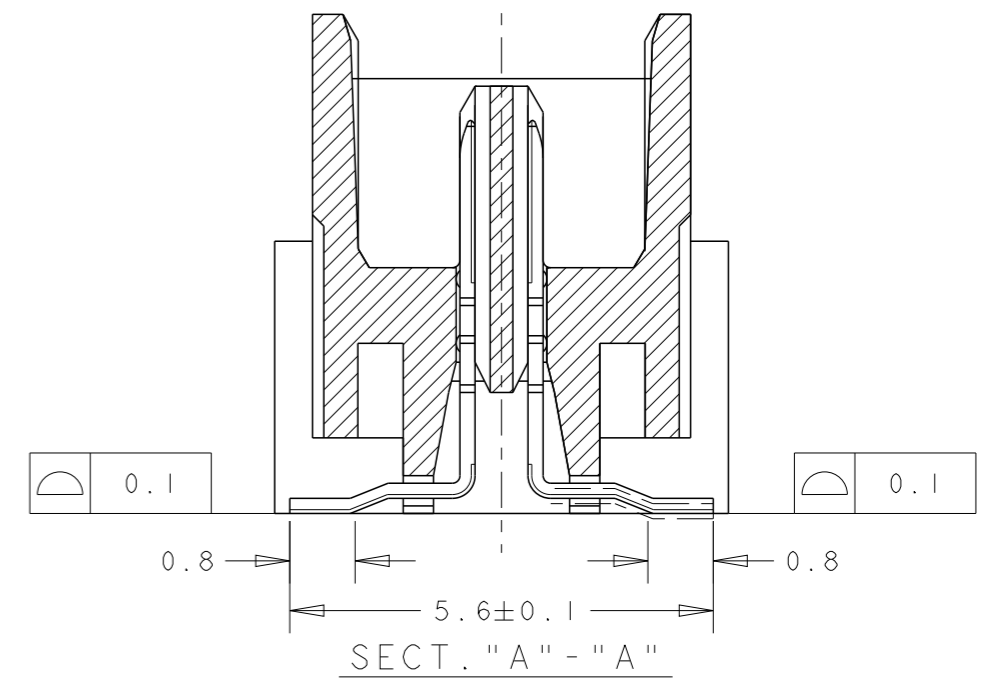
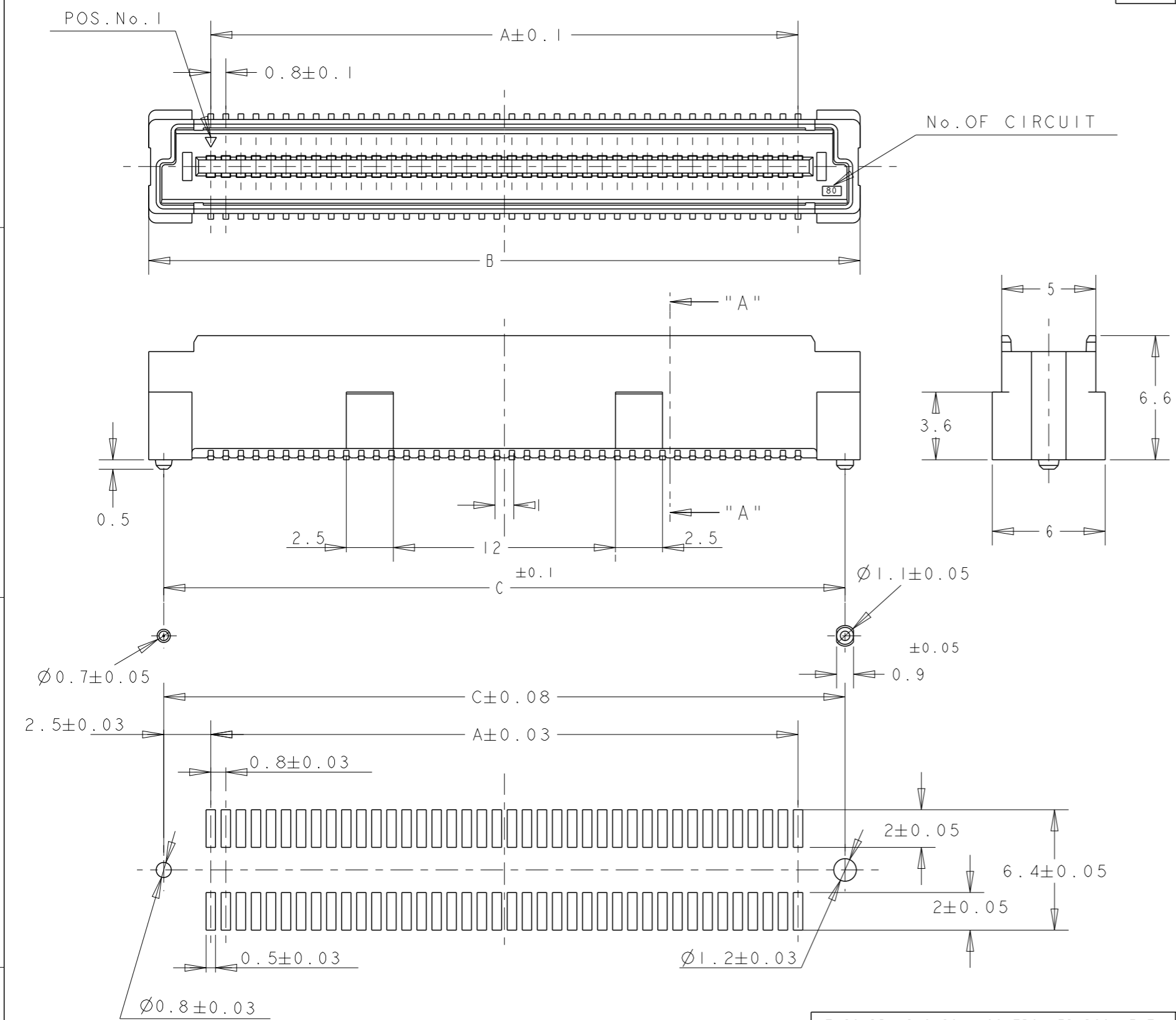

- NOTES:
- 1 MATERIAL:
HOUSING: L.C.P. (HIGH TEMP THERMO PLASTIC)
UL 94V-0, NATURAL.
CONTACT: BRASS.
 - 2 FINISH:
CONTACT AREA: 0.0002 MIN GOLD ON
0.0013 MIN ALL OVER NICKEL.
 - 3 SOLDERING AREA: 0.002 MIN MATTE-TIN.
 - 4 POSITION SERIES: SEE TABLE.
 - CONN STACK HEIGHT COMBINE OF PLUG "Y" H VS REC "X" H.
STACK HEIGHT = Y + X - 5
 - 5 FINISH:
CONTACT AREA: 0.00076 MIN GOLD ON
0.0013 MIN ALL OVER NICKEL.
SOLDERING AREA: 0.002 MIN MATTE-TIN.
 - 6 OBSOLETE PARTS: OBSOLETE CIS STREAMLINING PER D.RENAUD/D.SINISI.
 - 7 FINISH:
CONTACT AREA: 0.00038 MIN GOLD ON
0.0013 MIN ALL OVER NICKEL.
SOLDERING AREA: 0.002 MIN MATTE-TIN.

RECOMMENDED P.C. BOARD LAYOUT

P/N SEE SHEET 2 AND 3 OF 3

THIS DRAWING IS A CONTROLLED DOCUMENT.		DWN FLORENCE TAN 30AUG04	 TE Connectivity	
DIMENSIONS: mm		CHK ERIC TNG		
TOLERANCES UNLESS OTHERWISE SPECIFIED:		APVD SE LEONG	NAME PLUG ASSEMBLY 7H TYPE (0.5 BOSS LENGTH) FOR FH 0.8mm PITCH BTB CONNECTOR	
0 PLC ± 1 PLC ±0.30 2 PLC ±0.25 3 PLC ±0.20 4 PLC ± ANGLES ±3°		PRODUCT SPEC 108-5390	SIZE A300779	
MATERIAL		APPLICATION SPEC 114-5254	DRAWING NO C-5179030	
FINISH SEE P/N TABLE		WEIGHT -	RESTRICTED TO -	
		CUSTOMER DRAWING	SCALE 4:1	SHEET 1 OF 3
				REV B2

THIS DRAWING IS UNPUBLISHED. RELEASED FOR PUBLICATION 20
 © COPYRIGHT 20 BY - ALL RIGHTS RESERVED.

LOC	DIST	REVISIONS				
P	LTR	DESCRIPTION	DATE	DWN	APVD	
DY	-	SEE HEET 1				

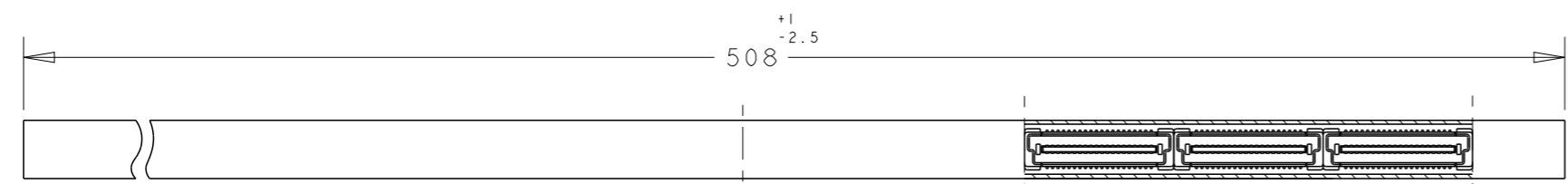

SECT A-A

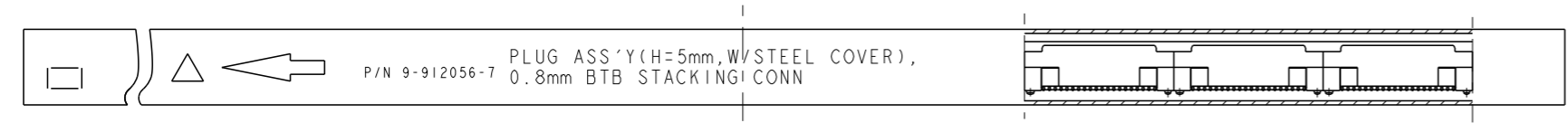

SECT B-B

P/N 9-912056-7 PLUG ASS'Y (H=5mm, W/STEEL COVER),
 0.8mm BTB STACKING CONN

REFERENCE PICTURE OF TUBE PACK

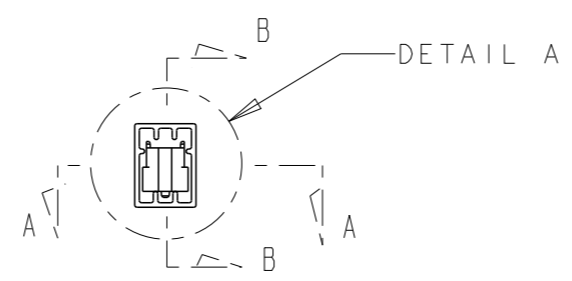

DETAIL A

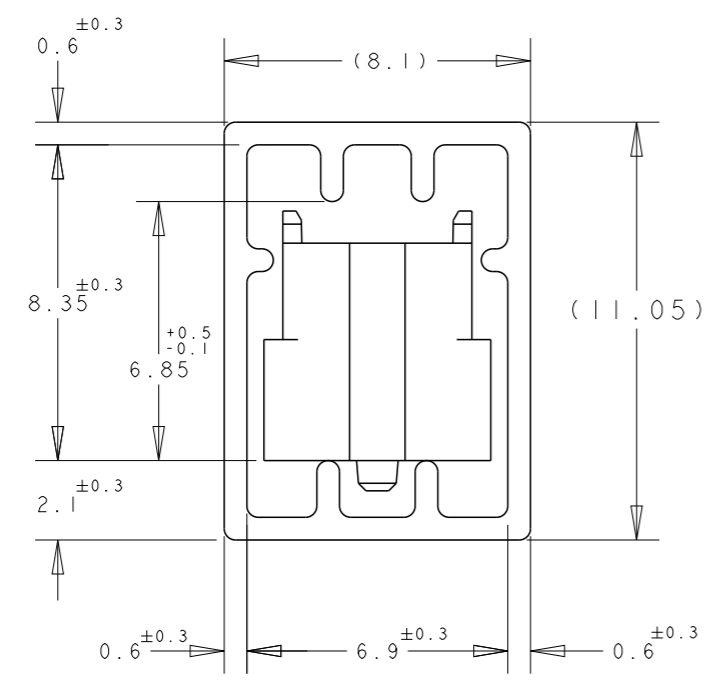

DETAIL "B"
(SCALE 5-1)

CNT	PLT	FINISH	AVAILABILITY	QTY/TUBE					CONN P/N	
				C	B	A	POS.			
5	15Au/Sn	△	NOT AVAILABLE	5	84.2	85.8	79.2	200	4-	-0
			NOT AVAILABLE	6	76.2	77.8	71.2	180	3-	-9
			NOT AVAILABLE	6	68.2	69.8	63.2	160	3-	-8
			NOT AVAILABLE	7	60.2	61.8	55.2	140	3-	-6
			AVAILABLE	9	52.2	53.8	47.2	120	3-	-5
			NOT AVAILABLE	10	44.2	45.8	39.2	100	3-	-4
			NOT AVAILABLE	12	36.2	37.8	31.2	80	3-	-3
			NOT AVAILABLE	16	28.2	29.8	23.2	60	3-	-2
			NOT AVAILABLE	22	20.2	21.8	15.2	40	3-	-1
			6	30Au/Sn	△	AVAILABLE	5	84.2	85.8	79.2
AVAILABLE	6	76.2				77.8	71.2	180	1-	-9
AVAILABLE	6	68.2				69.8	63.2	160	1-	-8
AVAILABLE	7	64.2				65.8	59.2	150	1-	-7
AVAILABLE	7	60.2				61.8	55.2	140	1-	-6
AVAILABLE	9	52.2				53.8	47.2	120	1-	-5
AVAILABLE	10	44.2				45.8	39.2	100	1-	-4
AVAILABLE	12	36.2				37.8	31.2	80	1-	-3
AVAILABLE	16	28.2				29.8	23.2	60	1-	-2
AVAILABLE	22	20.2				21.8	15.2	40	1-	-1
8	08Au/Sn	△	AVAILABLE	5	84.2	85.8	79.2	200	1-	-0
			AVAILABLE	6	76.2	77.8	71.2	180		-9
			AVAILABLE	6	68.2	69.8	63.2	160		-8
			AVAILABLE	7	64.2	65.8	59.2	150		-7
			AVAILABLE	7	60.2	61.8	55.2	140		-6
			AVAILABLE	9	52.2	53.8	47.2	120		-5
			AVAILABLE	10	44.2	45.8	39.2	100		-4
			AVAILABLE	12	36.2	37.8	31.2	80		-3
			AVAILABLE	16	28.2	29.8	23.2	60		-2
			AVAILABLE	22	20.2	21.8	15.2	40		-1

THIS DRAWING IS A CONTROLLED DOCUMENT. DWN FLORENCE TAN 30AUG04
 CHK ERIC TNG
 APVD SE LEONG
 PRODUCT SPEC 108-5390
 APPLICATION SPEC 114-5254
 WEIGHT -

STE TE Connectivity

NAME PLUG ASSEMBLY 7H TYPE
 (0.5 BOSS LENGTH)
 FOR FH 0.8mm PITCH BTB CONNECTOR

SIZE A300779 CAGE CODE G-5179030 DRAWING NO 5179030-1 RESTRICTED TO -

CUSTOMER DRAWING SCALE 4:1 SHEET 2 OF 3 REV B2

THIS DRAWING IS UNPUBLISHED. RELEASED FOR PUBLICATION 20
 © COPYRIGHT 20 BY - ALL RIGHTS RESERVED.

LOC	DIST	REVISIONS					
DY	-	P	LTR	DESCRIPTION	DATE	DWN	APVD
				SEE HEET 1			

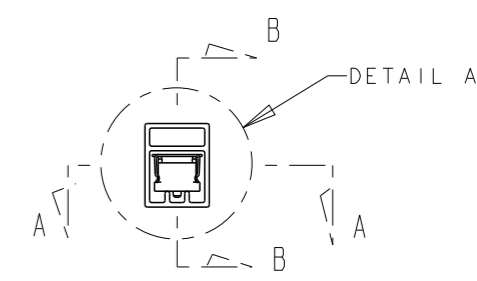
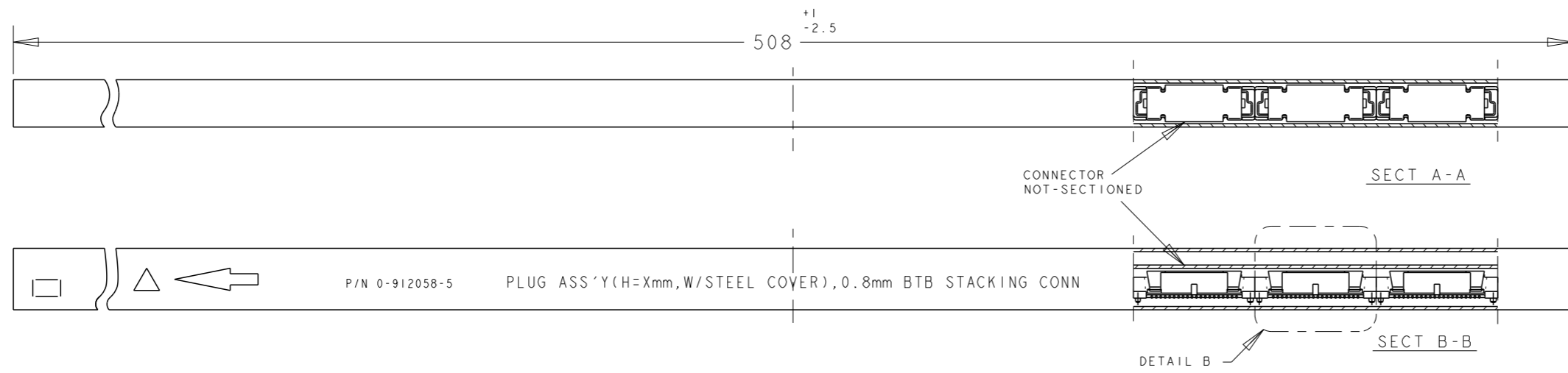

PLUG TUBE ASSY WITH STEEL COVER FOR FH 0.8 B-T-B CONNECTOR

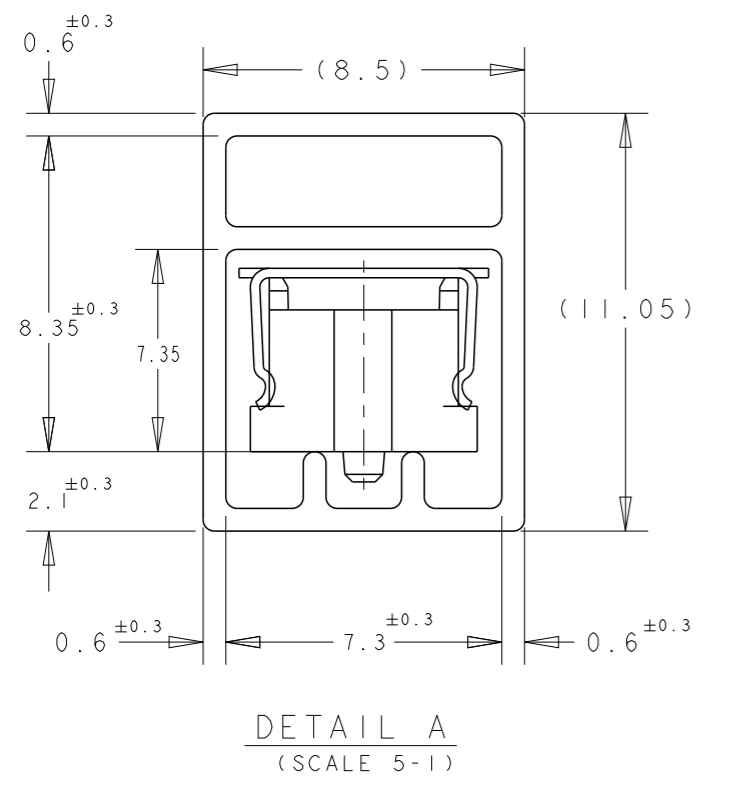
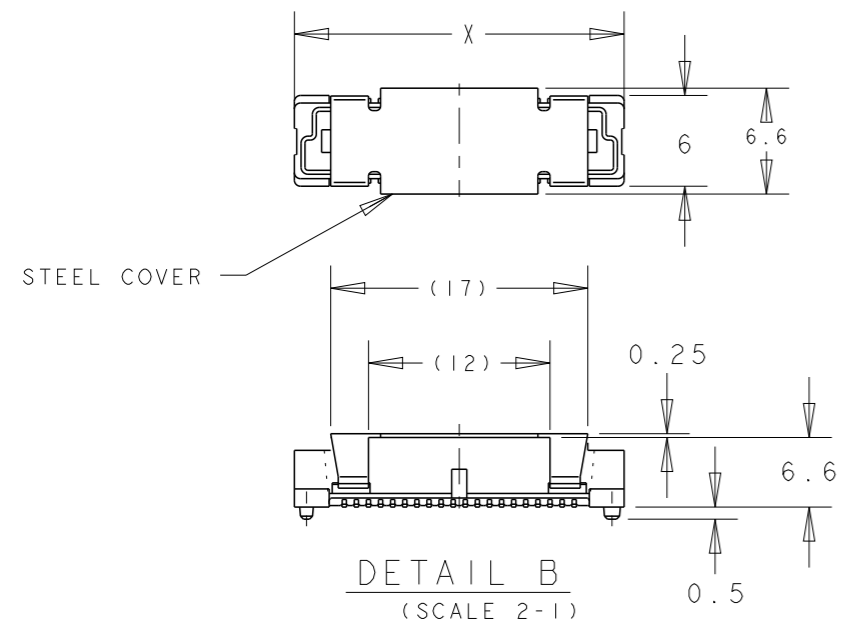

CNT PLT 30Au/Sn 5	AVAILABLE	5	85.8	200	3-	-0	
		6	77.8	180	2-	-9	
		6	69.8	160	2-	-8	
	WITH STEEL COVER	AVAILABLE	7	65.8	150	2-	-7
			7	61.8	140	2-	-6
			9	53.8	120	2-	-5
			10	45.8	100	2-	-4
			12	37.8	80	2-	-3
			16	29.8	60	2-	-2
22	21.8	40	2-5179030-1				
FINISH/REMARKS	AVAILABILITY	QTY/TUBE	X	POS.	CONN P/N		

THIS DRAWING IS A CONTROLLED DOCUMENT.		DWN FLORENCE TAN 30AUG04	STE TE Connectivity		
DIMENSIONS: mm		CHK ERIC TNG			
TOLERANCES UNLESS OTHERWISE SPECIFIED:		APVD SE LEONG	NAME PLUG ASSEMBLY 7H TYPE (0.5 BOSS LENGTH) FOR FH 0.8mm PITCH BTB CONNECTOR		
0 PLC ± 1 PLC ±0.30 2 PLC ±0.25 3 PLC ±0.20 4 PLC ± ANGLES ±3°		PRODUCT SPEC 108-5390	SIZE A300779		
MATERIAL		APPLICATION SPEC 114-5254	DRAWING NO C-5179030		
FINISH SEE P/N TABLE		WEIGHT -	RESTRICTED TO -		
		CUSTOMER DRAWING	SCALE 4:1	SHEET 3 OF 3	REV B2

PROJ NO. 593-312