

SOLDERING SIDE
 LOETSEITE

LOC	DIST	REV	DATE	BY	APPV
A1	-	1	18JUN2001	NG	GF
B1	-	2	23-FEB-04	EW	GF

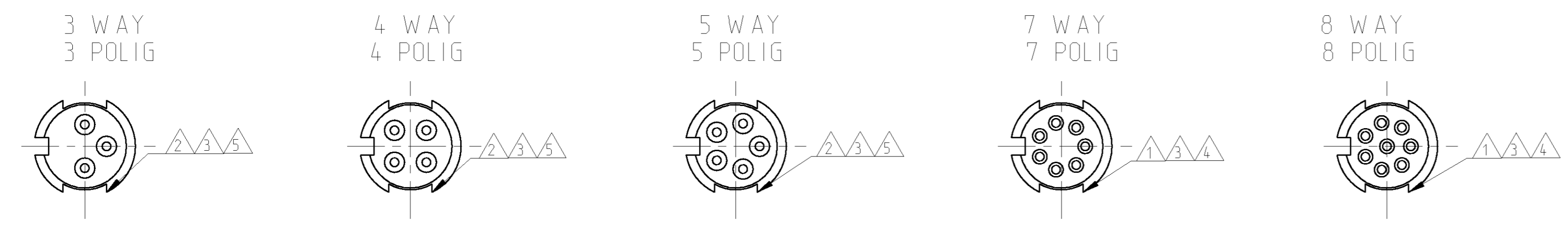

MATERIAL / MATERIAL: PBT, UL-94 V2 SHELL MATERIAL / GEHAUEMATERIAL: CUZN FINISH / BESCHICHTUNG: TRIBOR 4 µm	△6
WIRE GAGE / DRAHTGROESSE IN mm ² : 0.25	△5
WIRE GAGE / DRAHTGROESSE IN mm ² : 0.14	△4
CONTACT RESISTANCE / KONTAKTWIDERSTAND: => 5 mΩ	△3
RATED CURRENT PER CONTACT / NENNSTROM PRO KONTAKT: 3 A	△2
RATED CURRENT PER CONTACT / NENNSTROM PRO KONTAKT: 1 A	△1
SHELL PROTECTION CLASS / SCHUTZKLASSE: IP 65 / DIN 40050	
TERMINATION: SOLDERING / VERBINDUNG: LOETKONTAKTE	
TEST VOLTAGE / PRUEFSPANNUNG: 500 VAC	
OPERATING VOLTAGE / BETRIEBSSPANNUNG: 60 VAC	
OPERATING TEMPERATURE: -40°C TO +80°C / ARBEITSTEMPERATUR: -40°C BIS +80°C	
MATING CYCLES / STECKZYKLEN: 500 MAX.	
TECHNICAL DATA TECHNISCHE DATEN	

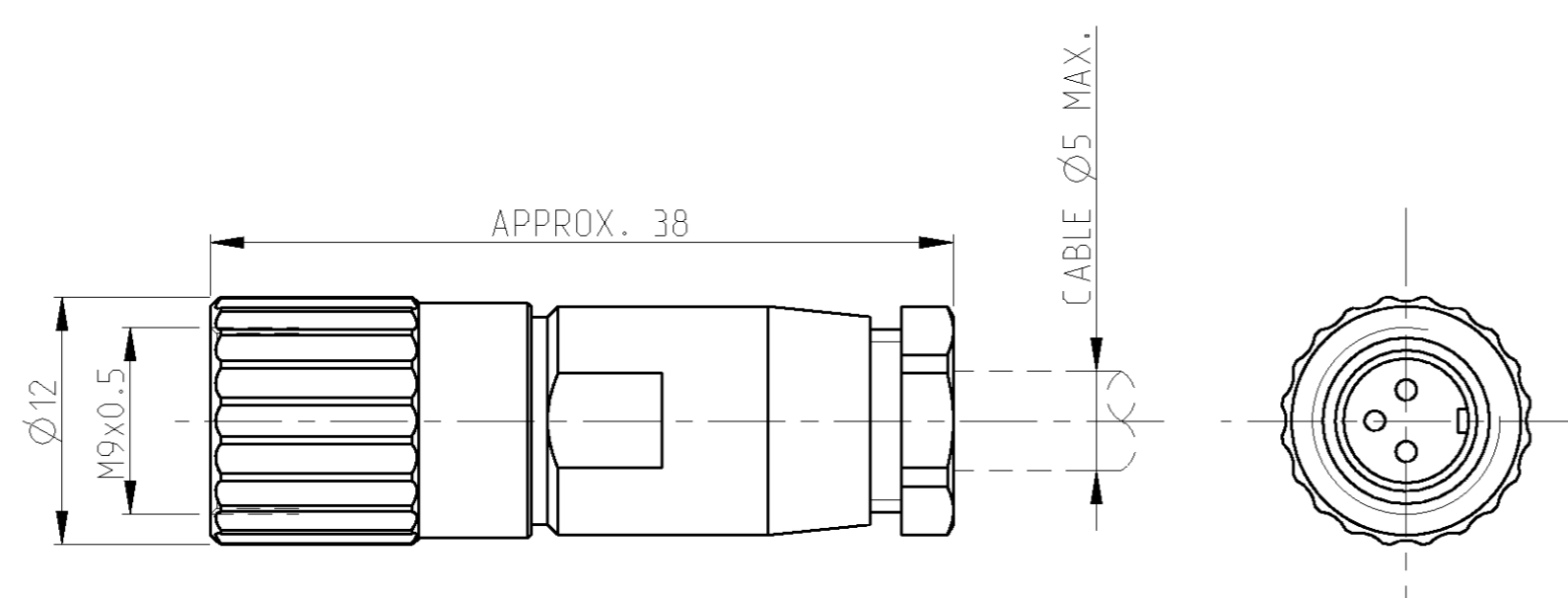
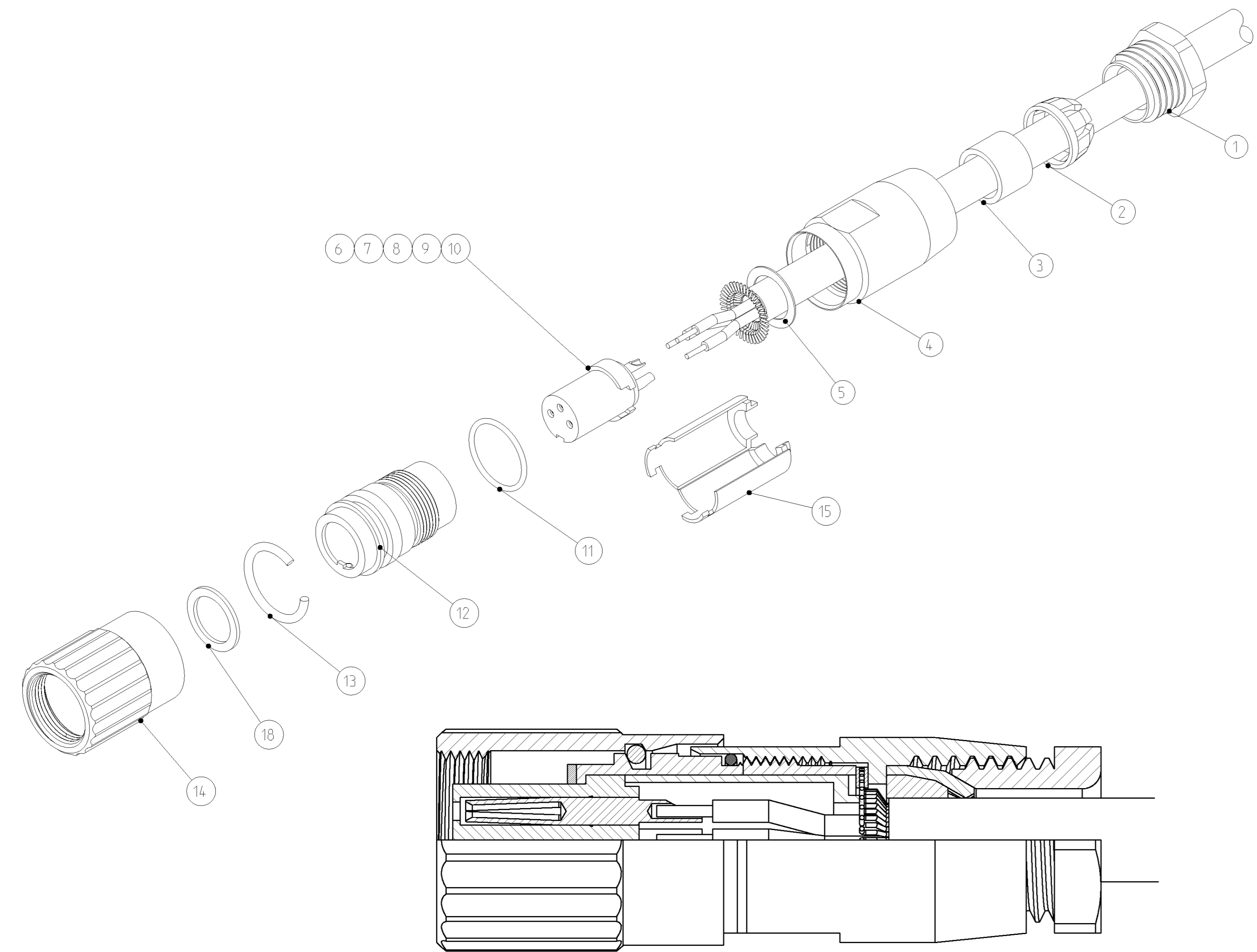

TYCO NO. / TYCO-NR.	QTY REQD PER ASSY	DESCRIPTION BESCHREIBUNG	ITEM NO. POS.-NR.
4-1437719-2	1	MOUNTING WRENCH / MONTAGESCHLUESSEL	19
3-1437719-9	1	SEALING PAD / GUMMIDICHTUNG	18
3-1437719-6	1	COMPLETELY IN MINI-GRIP / KOMPLETT IN MINI-GRIP-BEUTEL: 70x100mm }	17
3-1437719-3	1	MOUNTING INSTRUCTION / MONTAGEANLEITUNG	16
3-1437719-0	1	INSULATION TUBE / ISOLIERHUELSE	15
	1	SCREWING TUBE / SCHRAUBHUELSE	14
	1	SPRING / FEDER	13
	1	TUBE / INNENHUELSE	12
	1	O-RING / O-RING	11
	1	CONTACT CARRIER 8 WAY/BUCHSENSTECKER 8 POLIG	10
	1	CONTACT CARRIER 7 WAY/BUCHSENSTECKER 7 POLIG	9
	1	CONTACT CARRIER 5 WAY/BUCHSENSTECKER 5 POLIG	8
	1	CONTACT CARRIER 4 WAY/BUCHSENSTECKER 4 POLIG	7
	1	CONTACT CARRIER 3 WAY/BUCHSENSTECKER 3 POLIG	6
	1	GROUNDING PLATE FOR 360°SHIELDING CONNECTION/ MASSESCHIEBE FUER 360°ABSCHIRMUNG	5
	1	HOUSING / GEHAUESE	4
	1	CABLE SEALING / KABELDICHTUNG	3
	1	STRAIN RELIEF / ZUGENTLASTUNGSKRONE	2
	1	STRAIN RELIEF NUT / ZUGENTLASTUNGSMUTTER	1
		REVISION OF EACH ASSY NO. (WHEN BLANK, USE DWG REV.)	

DIMENSIONS: MASSENHEITEN: (mm)	TOLERANCES, UNLESS OTHERWISE SPECIFIED: ALLERGENAUERHEITEN: (UNLESS OTHERWISE SPECIFIED)	DWG NO.: H. SCHNEIDER DATE: 18JUN2001 APPV: H. SCHNEIDER DATE: 18JUN2001	NAME: T101 FEMALE PLUG CONNECTOR SOLDER VERSION 3-8 POS. T101 BUCHSENSTECKER LOETVERSION 3-8 POL.
MATERIAL: -	FINISH: -	WEIGHT: - BEWICHT: -	SIZE: A1 CAGE CODE: 00779 DRAWING NO.: 3-1437719-0 RESTRICTED TO: MR PER -
CUSTOMER DRAWING		SCALE: -	SHEET: 1 OF 1 REV: B1

3-1437719-0 AS SHOWN
 WIE GEZEICHNET