

DESCRIPTION

The EV4575-F-00A is an evaluation board for the MP4575, a frequency programmable step-down switching converter with integrated internal high-side and low side power MOSFETs. It can provide 5A continuous output current with peak current control for excellent transient response and efficiency performance.

The wide 4.5V to 55V input voltage range accommodates a variety of step down applications, including those applications in industrial, PoE, automotive and printer with DC high voltage bus.

The valley current detection is used to avoid current running way at over current protection. Also it has accurate and reliable over voltage protection, and auto recovery thermal protection. In addition, the optional external soft start is available. Enable and power good indication function can be used to power track easily. In order to increase the efficiency, MP4575 will automatically scaling down the switching frequency when load is light. Meanwhile, the low side MOSFET will be turned off to reduce driver loss when zero inductor current is detected. Synchronous operation mode with integrated low side MOSFET is much helpful to reduce the conduction loss and also beneficial to reduce external components space and save the cost.

The MP4575 is available in a TSSOP-20 EP with exposed pad package.

ELECTRICAL SPECIFICATIONS

Parameter	Symbol	Value	Units
Input Voltage	V_{IN}	4.5-55	V
Output Voltage	V_{OUT}	3.3	V
Output Current	I_{OUT}	5	A

FEATURES

- Wide Input Voltage Range: 4.5V to 55V
- Programmable Switching Frequency
- Optional External Soft Start
- Peak Current Mode Control
- OCP Protection with Valley Current Detection
- Support External SYNC Clock
- OVP Protection
- Current Limit Decreasing during Output Short for Better Thermal Performance
- Power Good Indication
- Thermal Shutdown Protection
- Fully Assembled and Tested

APPLICATIONS

- PoE Input Non-isolated Buck
- Industrial Power Systems
- Printers and Scanners
- Automotive Power Systems
- Distributed Power Systems

All MPS parts are lead-free and adhere to the RoHS directive. For MPS green status, please visit MPS website under Quality Assurance. "MPS" and "The Future of Analog IC Technology" are Registered Trademarks of Monolithic Power Systems, Inc.

EV4575-F-00A EVALUATION BOARD



(L x W x H) 2.5" x 2.5" x 0.2"
(6.4cm x 6.4cm x 0.5cm)

Board Number	MPS IC Number
EV4575-F-00A	MP4575GF

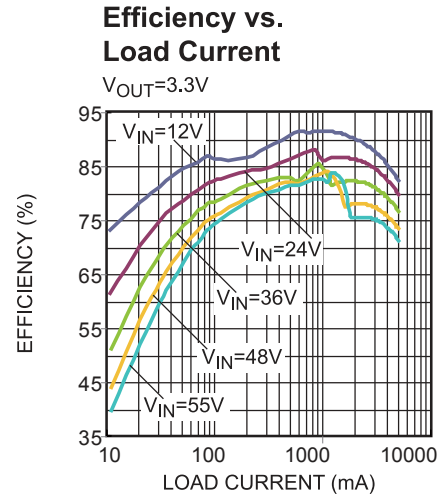

EVALUATION BOARD SCHEMATIC

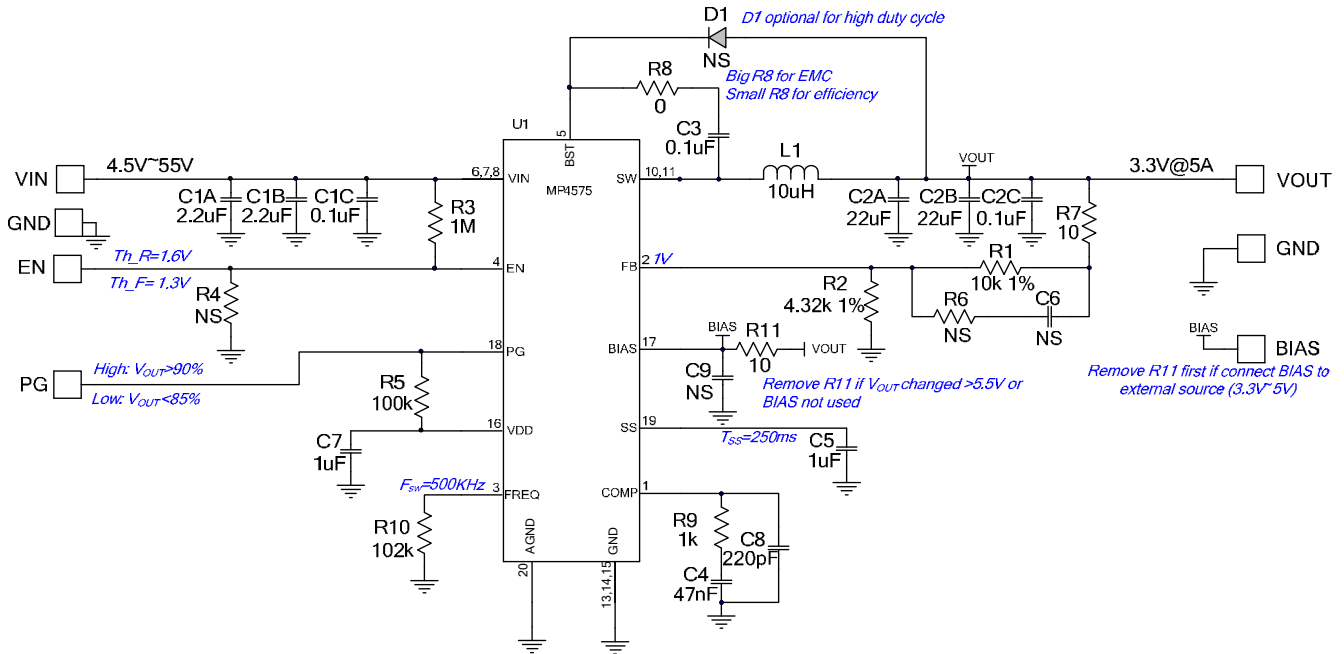

Reference for R_{FREQ} Selection

F _{sw} (KHz)	R10(KΩ)
1000	47.5
900	56
800	63.4
700	73.2
600	84.5
500	102
400	133
300	178
200	261
100	523

Reference for FB Divider Selection

V _{OUT} (V)	R1(KΩ)	R2(KΩ)
1.8	10 (1%)	12.4 (1%)
2.5	10 (1%)	6.65 (1%)
3.3	10 (1%)	4.32 (1%)
5	10 (1%)	2.49 (1%)
12	20 (1%)	1.82 (1%)

Reference for C_{SS} Selection

t _{SS} (ms)	C5(nF)
250	1000
25	100
2.5	10

TOP VIEW

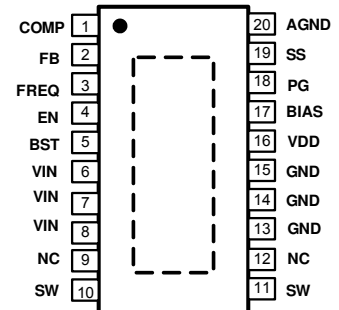

TSSOP-20 EP Package

EV4575-F-00A BILL OF MATERIALS

Qty	Ref	Value	Description	Package	Manufacture	Part Number
2	C1A,C1B	2.2uF	Ceramic Capacitor;100V;X7R	1210	muRata	GRM32ER72A225KA35L
1	C1C	0.1uF	Ceramic Capacitor;100V;X7R	0603	muRata	GRM188R72A104KA35D
2	C2A,C2B	22uF	Ceramic Capacitor;16V;X7R	1210	muRata	GRM32ER71C226KE18L
2	C2C,C3	0.1uF	Ceramic Capacitor;16V;X7R	0603	muRata	GRM188R71C104KA01D
1	C4	47nF	Ceramic Capacitor;50V;X7R	0603	muRata	GRM188R71H473KA61D
2	C5,C7	1uF	Ceramic Capacitor;16V;X7R	0603	muRata	GRM188R71C105KA12D
1	C6	NS				
1	C8	220pF	Ceramic Capacitor;50V;C0G	0603	muRata	GRM1885C1H221JA01D
1	C9	NS				
2	R1,R12	10K	Film Resistor;1%;	0603	Yageo	RC0603FR-0710KL
1	R2	4.32K	Film Resistor;1%;	0603	Yageo	RC0603FR-074K32L
1	R3	1M	Film Resistor;5%;	0603	Yageo	RC0603JR-071ML
1	R4	NS				
1	R5	100K	Film Resistor;1%;	0603	Yageo	RC0603FR-07100KL
1	R6	NS				
2	R7,R11	10	Film Resistor;1%;	0603	Yageo	RC0603FR-0710RL
1	R8	0	Film Resistor;5%;	0603	Yageo	RC0603JR-070RL
1	R9	1K	Film Resistor;1%;	0603	Yageo	RC0603FR-071KL
1	R10	102K	Film Resistor;1%;	0603	Yageo	RC0603FR-07102KL
1	D1	NS				
1	L1	10uH	Inductor;8.7A;23.1mhm DCR	SMD	Coilcraft	XAL8080-103MEB
1	U1		Step-Down Converter	TSSOP20	MPS	MP4575GF
4	VIN, GND, GND, VOUT		2.0 Golden Pin		Any	
11	PG,GND,BIAS,EN,GND		2.0mm Test Pin		Any	

EVB TEST RESULTS

$V_{IN} = 48V$, $V_{OUT} = 3.3V$, $C_{OUT} = 2 \times 22\mu F$, $L = 10\mu H$, $f_{SW} = 500KHz$, $T_A = +25^\circ C$, unless otherwise noted.

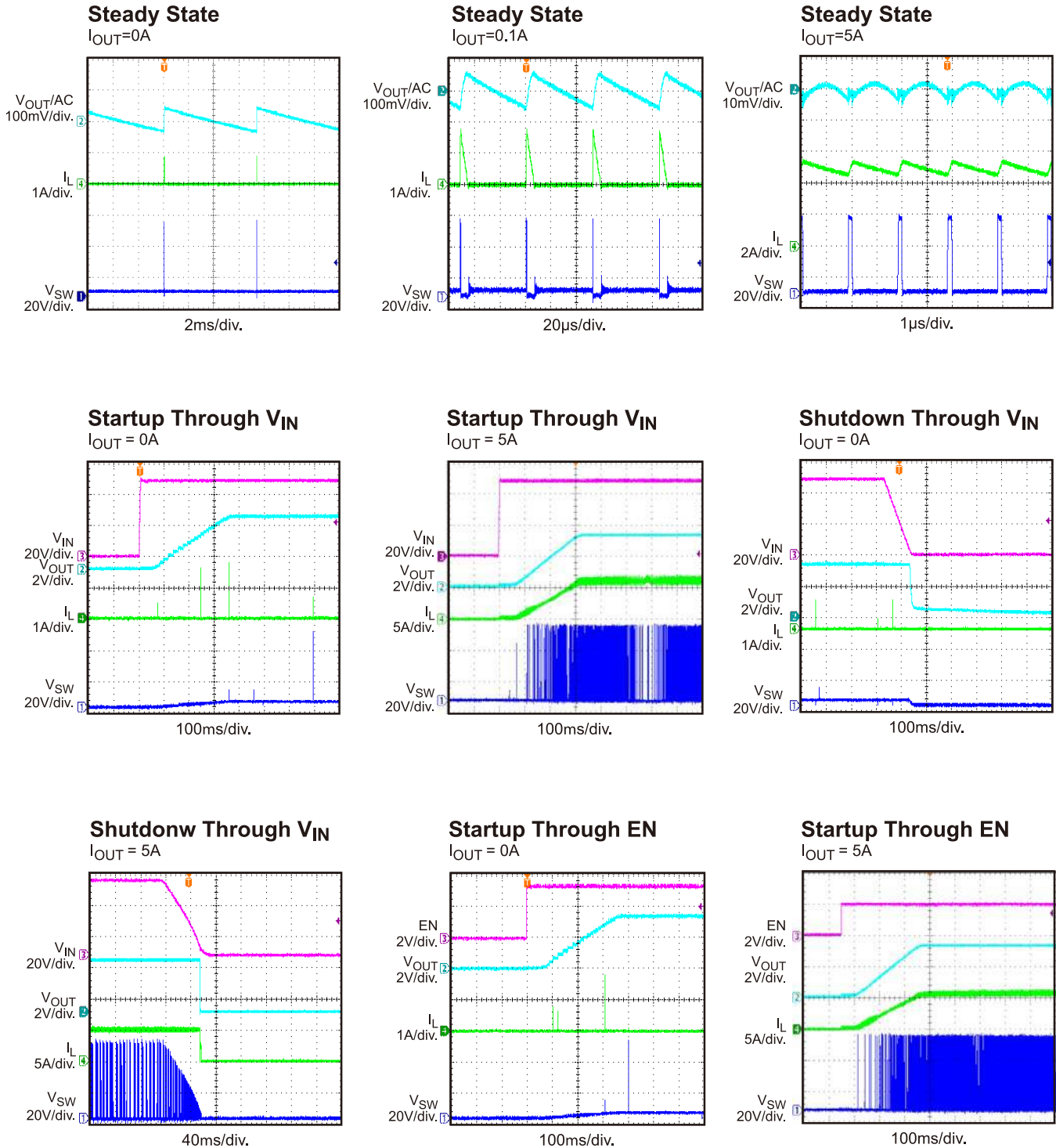

EVB TEST RESULTS

$V_{IN} = 48V$, $V_{OUT} = 3.3V$, $C_{OUT} = 2 \times 22\mu F$, $L = 10\mu H$, $f_{SW} = 500KHz$, $T_A = +25^\circ C$, unless otherwise noted.

Shutdown Through EN

$I_{OUT} = 0A$

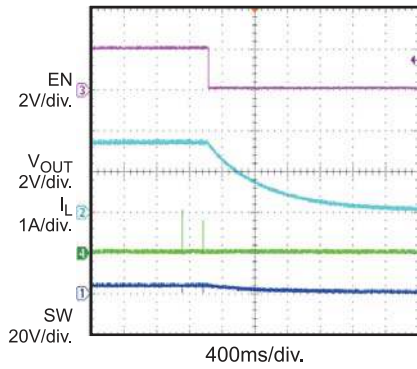

Shutdown Through EN

$I_{OUT} = 5A$

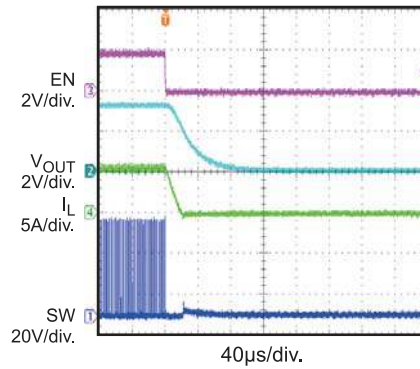

SCP Entry

$I_{OUT} = 0A$ to Short Circuit

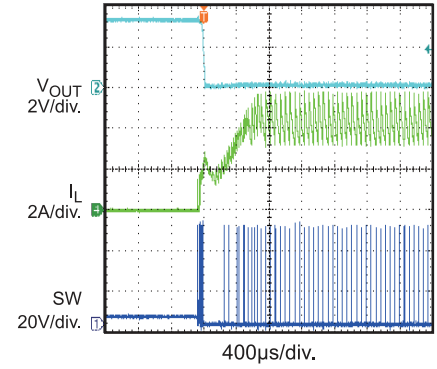

SCP Entry

$I_{OUT} = 5A$ to Short Circuit

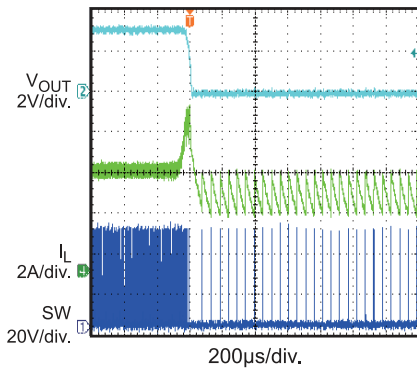

SCP Recovery

$I_{OUT} =$ Short Circuit to 0A

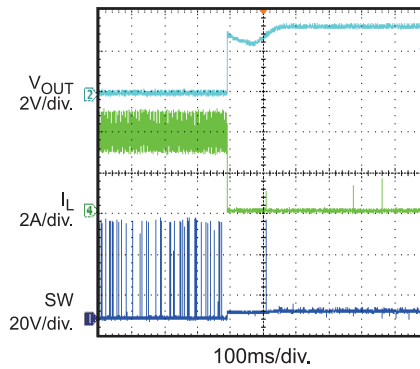

SCP Recovery

$I_{OUT} =$ Short Circuit to 5A

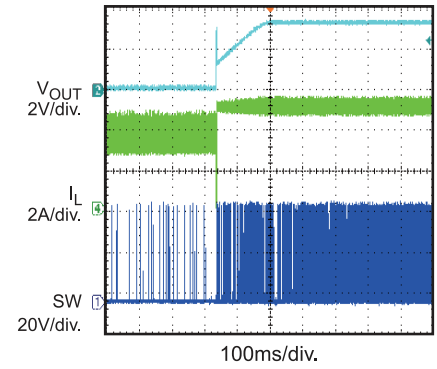

SCP Steady State

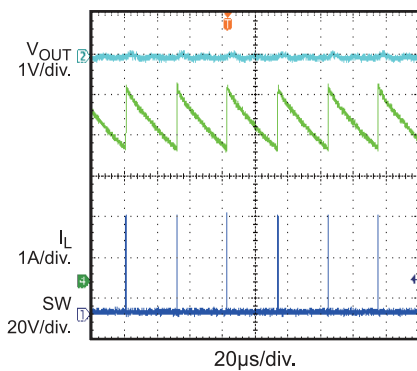

Load Transient

$I_{OUT} = 2.5A \leftrightarrow 5A$, $160mA/\mu s$

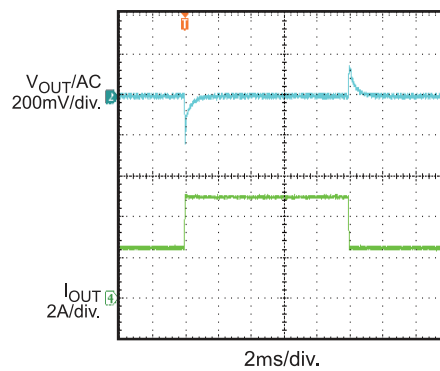

EVB TEST RESULTS *(continued)*

$V_{IN} = 48V$, $V_{OUT} = 3.3V$, $C_{OUT} = 2 \times 22\mu F$, $L = 10\mu H$, $f_{SW} = 500KHz$, $T_A = +25^\circ C$, unless otherwise noted.

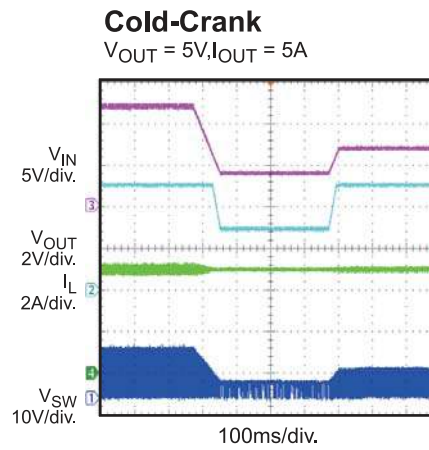
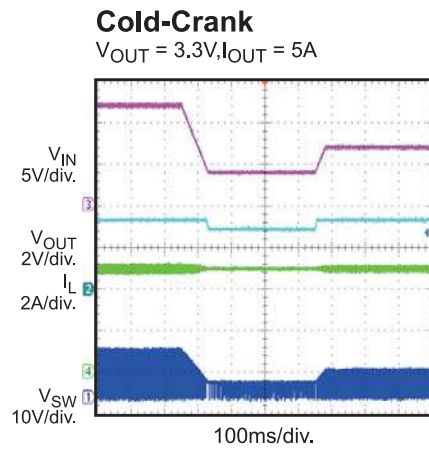

PRINTED CIRCUIT LAYOUT

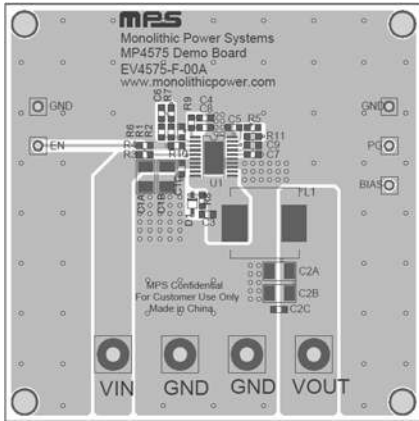

Figure1 – Top Silk Layer and Top Layer

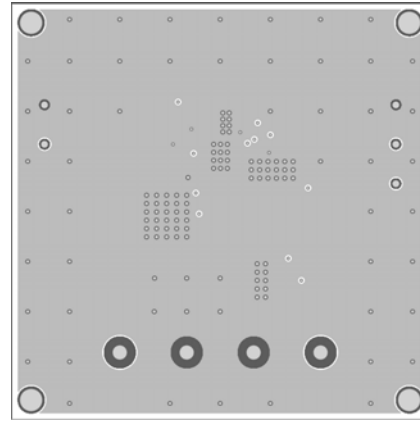

Figure 2 – Inner Layer 1

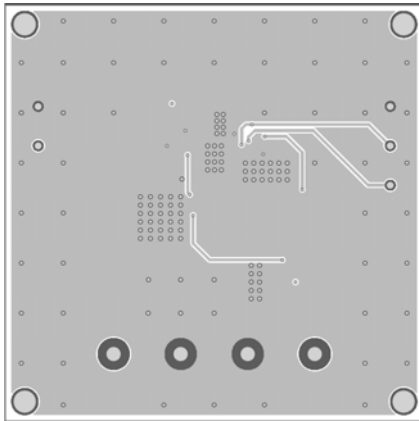

Figure3 – Inner Layer 2

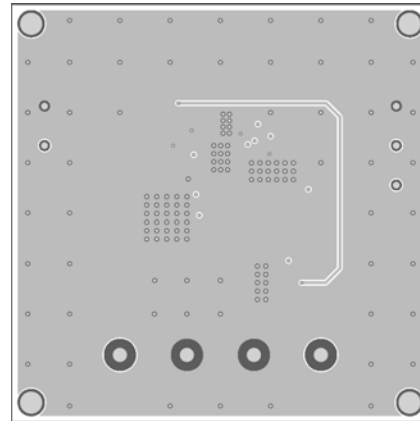

Figure 4 – Bottom Layer

NOTICE: The information in this document is subject to change without notice. Users should warrant and guarantee that third party Intellectual Property rights are not infringed upon when integrating MPS products into any application. MPS will not assume any legal responsibility for any said applications.

QUICK START GUIDE

1. Connect the positive and negative terminals of the load to the V_{OUT} and GND pins respectively. Set load current between 0-5A. Be aware that electronic loads represent a negative impedance to the regulator and if set to a too high current will trigger OCP mode.
2. Preset the power supply output to between 4.5V to 55V, and then turn it off. If longer cables are used between the source and EVB (>0.5m total), a damping capacitor should be installed at the input terminals. Especially when V_{IN} is $\geq 24V$.
3. Connect the positive and negative terminals of the power supply output to the V_{IN} and GND pins respectively.
4. Turn the power supply on. The MP4575 will automatically startup. The default V_{OUT} is 3.3V.
5. To use the Enable function, apply a digital input to the EN pin. Drive EN higher than 1.6V to turn on the regulator, drive EN less than 1.3V to turn it off. There is no internal pull-up or pull-down circuit, so do not float this pin.
6. Connection the EN pin directly to a voltage source without any pull-up resistors requires limiting voltage amplitude to $\leq 6V$ to prevent damage to the internal zener diode between EN and GND; EN pin can also be connected to higher voltage (e.g. V_{IN}) through pull-up resistor, but need to make sure the pull-up resistor is high enough to make sure the sink current into EN pin less than $150\mu A$ to avoid damaging the zener diode. For example, when connecting EN to $V_{IN}=12V$, $R_{pull-up} \geq (12V - 6.5V) \div 150\mu A = 37k\Omega$.
7. Output voltage set. The output voltage is set by the external resistor divider ($R1/R2$). Calculate the output voltage with below equation:

$$V_{OUT} = V_{FB} \times \frac{R1+R2}{R2}$$

Where $V_{FB}=1V$. Below table lists the recommended $R1/R2$ values for common output voltages.

$V_{OUT}(V)$	$R1(K\Omega)$	$R2(K\Omega)$
1.8	10 (1%)	12.4 (1%)
2.5	10 (1%)	6.65 (1%)
3.3	10 (1%)	4.32 (1%)
5	10 (1%)	2.49 (1%)
12	20 (1%)	1.82 (1%)

8. Switching frequency (F_{SW}) set. F_{SW} can be set by the resistor $R10$ at $FREQ$ (R_{FREQ}). Below table shows recommended $R10$ values for various F_{SW} values.

$F_{SW}(KHz)$	$R10(K\Omega)$
1000	47.5
900	56
800	63.4
700	73.2
600	84.5
500	102
400	133
300	178
200	261
100	523

Fsw also can be synchronized by an external clock added at FREQ pin. Ensure that the high amplitude of the synchronous (SYNC) clock is higher than 1.5V and the low amplitude is lower than 1V to drive the internal logic. 100kHz to 1MHz SYNC frequency and longer than 100ns pulse are recommended in application.

- Soft start set. The soft-start time (t_{SS}) is set by the external SS capacitor (C5). It can be calculated with below equation:

$$t_{SS}(\text{ms}) = \frac{C5(\text{nF}) \times V_{REF}(\text{V})}{I_{SS}(\mu\text{A})}$$

Where V_{REF} is the internal reference voltage (1V), and I_{SS} is the 4 μ A SS charge current. Below table shows recommended C5 values for various t_{SS} values.

$t_{SS}(\text{ms})$	C5(nF)
250	1000
25	100
2.5	10

- BIAS connection. To use BIAS to power the internal regulator can improve efficiency. It is recommended to connect BIAS to a power supply in the range of 3.3V to 5.5V. The output voltage is a good choice for this power supply if it is in above range. If BIAS will be connected to an external power supply, remove R11 first and a 0.1 μ F to 1 μ F decoupling capacitor at BIAS is recommended. If BIAS is not used, it can be float.
- PG function. PG is the open drain of the internal MOSFET. PG should be connected to VDD (or an external voltage source) through a resistor (i.e.: 100k Ω). When V_{OUT} reaches 90% of the setting voltage PG goes to high level (VDD), while when V_{OUT} drops to 85% of the setting voltage PG voltage is pulled to GND to indicate a failure output status. If PG is not used, it can be float.
- External bootstrap diode (D1). If V_{OUT} is set between 2.5V-5V, D1 is recommended to be added to help charge the bootstrap capacitor and enhance efficiency. The bootstrap diode can be a low-cost one such as IN4148 or BAT54.