

NOTES:

1. FOR WAVESOLDERING(SOLDER BATH TEMPERATURE 240°C FOR 5 SEC. AND SOLDER PREHEAT 120°C FOR 120 SEC.)
2. METALSHELLS: STAINLESS STEEL
3. INSULATORS: PBT GF UL 94 V-0, BLACK
4. CONTACTS: COPPER ALLOY
PLATING (SEE PART NO):
 - PLEASE ADD C for 30µin HARD GOLD over min. 50µin NICKEL
 - PLEASE ADD B for 20µin HARD GOLD over min. 50µin NICKEL
 - PLEASE ADD A for GOLD FLASH over NICKEL (PREFERRED TYPE)
5. THREADED SPACER CLIPS: COPPER ALLOY;
min. 200µin TIN over 80µin NICKEL
PCB-HOLE: Ø3,1±0,1; PCB THICKNESS 1,6mm
6. COLLARS: COPPER ALLOY; min. 200µin TIN over 80µin NICKEL
7. FRAME: ZINC DIE CAST; NICKEL PLATED
8. O-RING: SILICON; BLUE
9. SEALING COMPOUND: PUR;BLUE
10. HEXLOCKING SCREWS: STAINLESS STEEL
11. PCB HOLE DRILLINGS
AND RECOMMENDED PANEL CUT-OUT ON SHEET 2
12. RECOMMENDED TORQUE FOR MOUNTING SCREW 35Ncm (3.1 in.LB) / max.40Ncm (3.5 in.LB)
13. CONNECTOR IS PART MARKED: 8HDD62S□R99E10X CONEC ABC (see note 4)

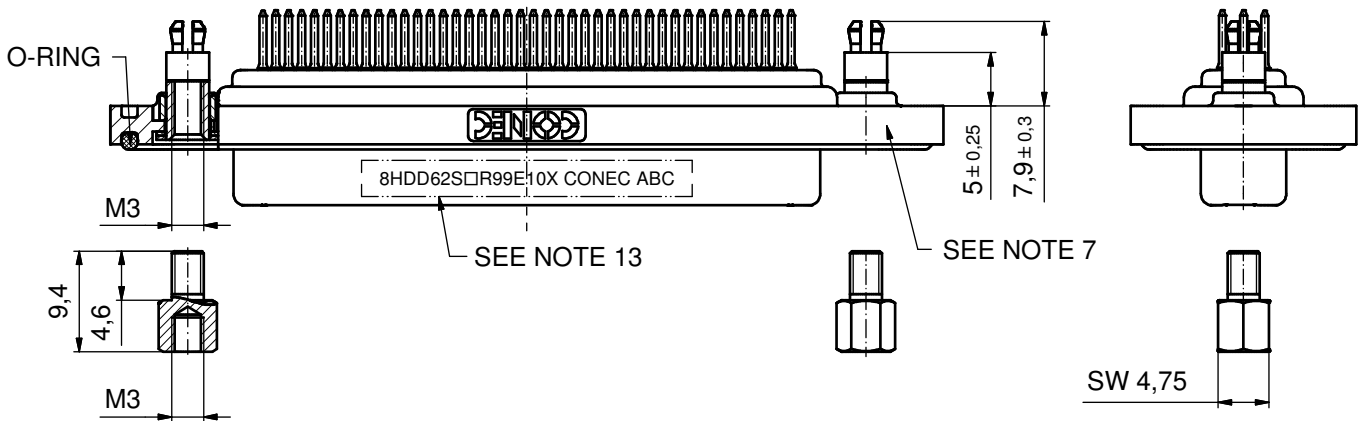
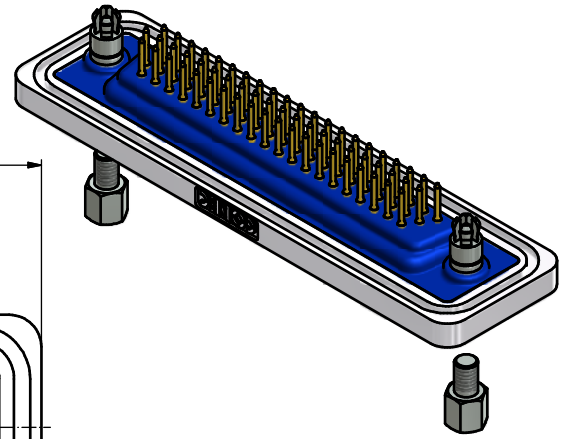
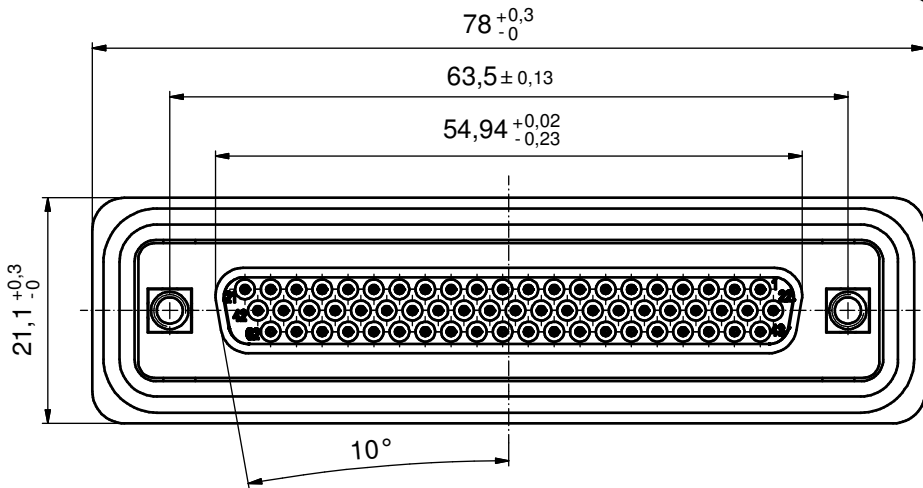
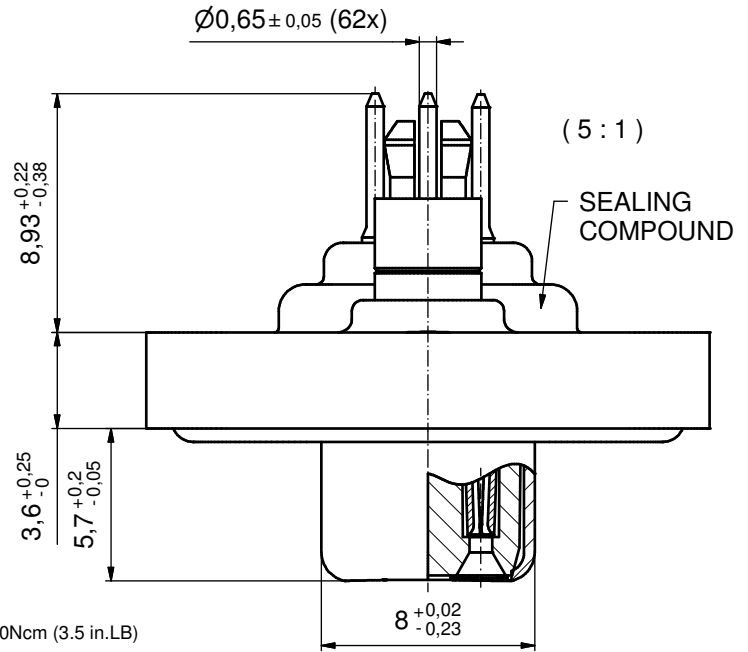

AT ALL TIMES WATER RESISTANT CONNECTORS NOT IN USE SHOULD BE COVERED WITH A CONEC WATER RESISTANT CAP OR WATER TIGHT HOOD.

Directive 2002/95/EC RoHS compliant

THIS DRAWING MAY NOT BE COPIED OR REPRODUCED IN ANY WAY, AND MAY NOT BE PASSED ON TO A THIRD PARTY WITHOUT WRITTEN PERMISSION. OWNERSHIP AND COPYRIGHT OF CONEC GmbH DO NOT ALTER CAD DRAWING BY HAND	tolerance		dim. in mm	scale: 2:1
	date			material: SEE NOTES
	drawn	12.06.12	Henneboel	title: D-SUB HD FEMALE 62pos. SOLDER PIN STRAIGHT with threaded spacer clip and hexlocking screw
	appd.	12.06.12	Fischer	
	norm			
d-old			dwg no:	DIN-A3
a	Original			sh: 1/2
rev.	description	date	name	part no: 8HDD62S□R99E10X (see note 4)



P.C.B. HOLE DRILLINGS
(P.C.B. TOP SIDE)

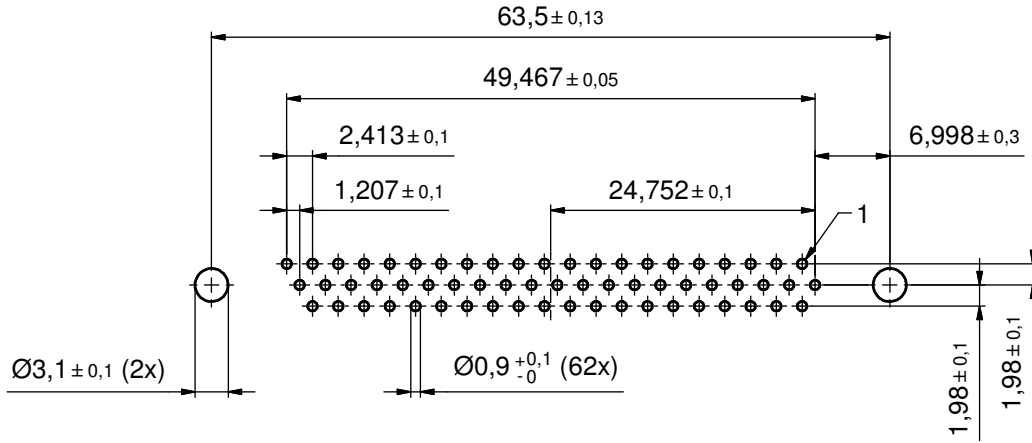

RECOMMENDED PANEL CUT-OUT

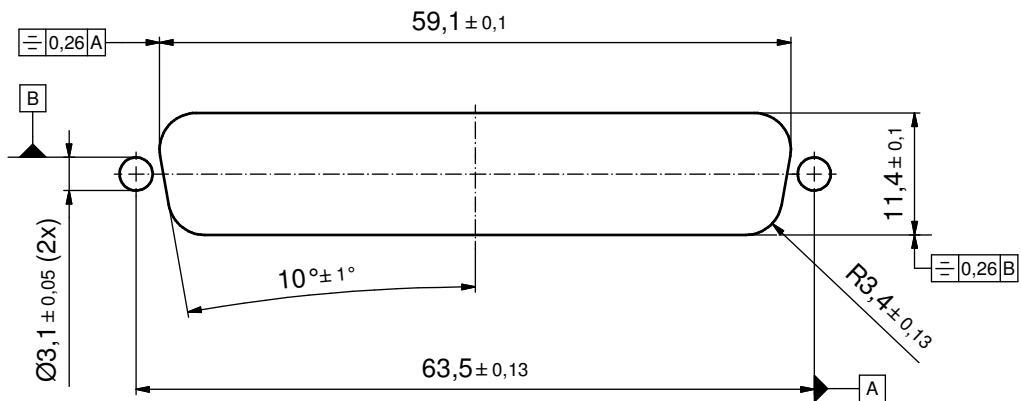

THIS DRAWING MAY NOT BE COPIED OR REPRODUCED IN ANY WAY, AND MAY NOT BE PASSED ON TO A THIRD PARTY WITHOUT WRITTEN PERMISSION. OWNERSHIP AND COPYRIGHT OF CONEC GmbH DO NOT ALTER CAD DRAWING BY HAND				tolerance		scale: 2:1
				dim. in mm		material: see sheet 1
	drawn	12.06.12	Henneboel	title:		
	appd.	12.06.12	Fischer	P.C.B. HOLE DRILLINGS		
	norm			D-SUB HD FEMALE 62pos. SOLDER PIN		
	d-old			with threaded spacer clip and hexlocking screw		
rev.	a	Original	CONEC®			dwg no: 15K1A1059
description			part no: SEE SHEET 1			DIN-A3 sh: 2/2