

LOC	DIST	REVISIONS				
DF	AO	REV	DESCRIPTION	DATE	OWN	APVD
		C	REV PER 0G3D-0439-03	10-03	CT	SG

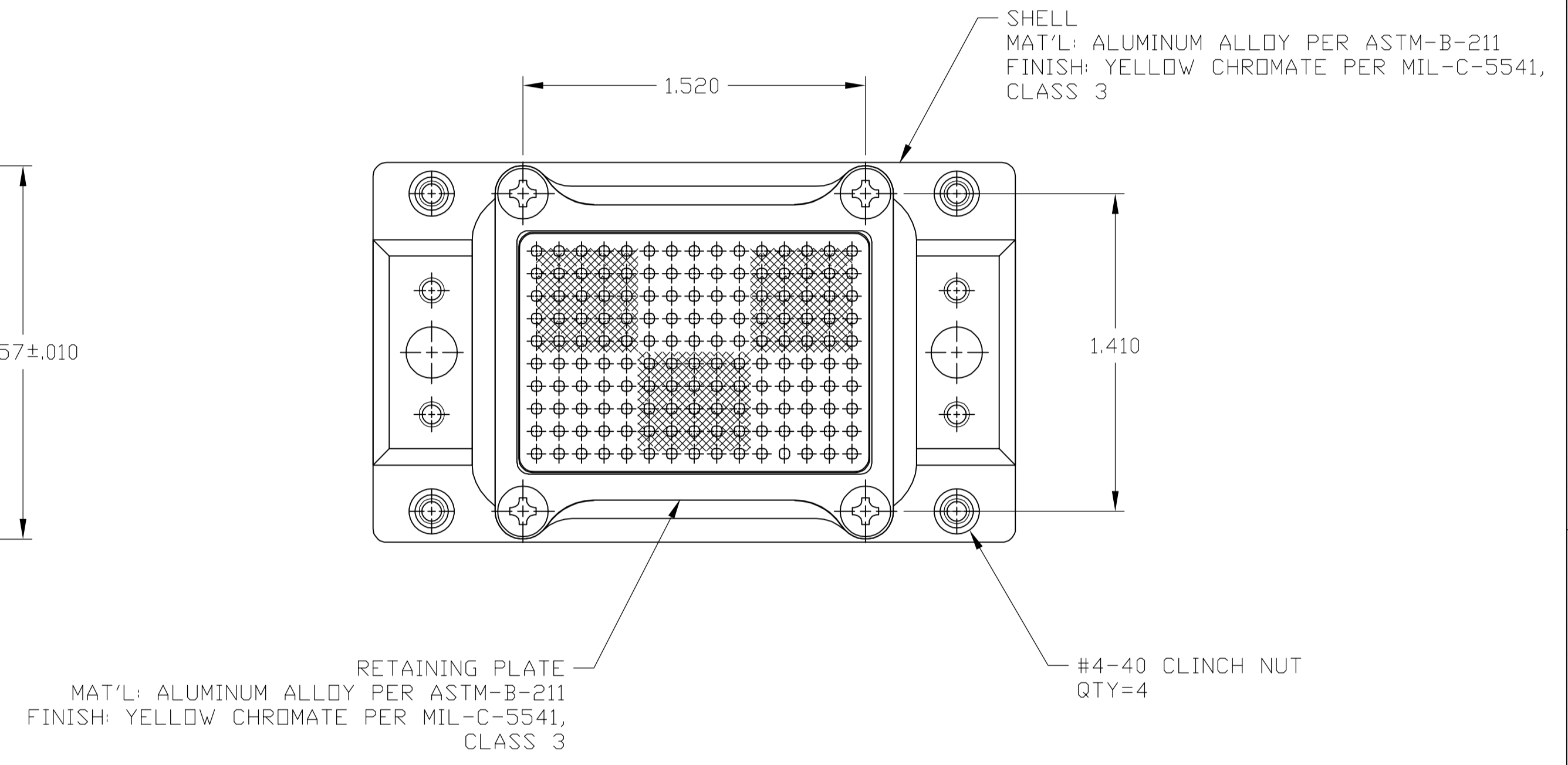
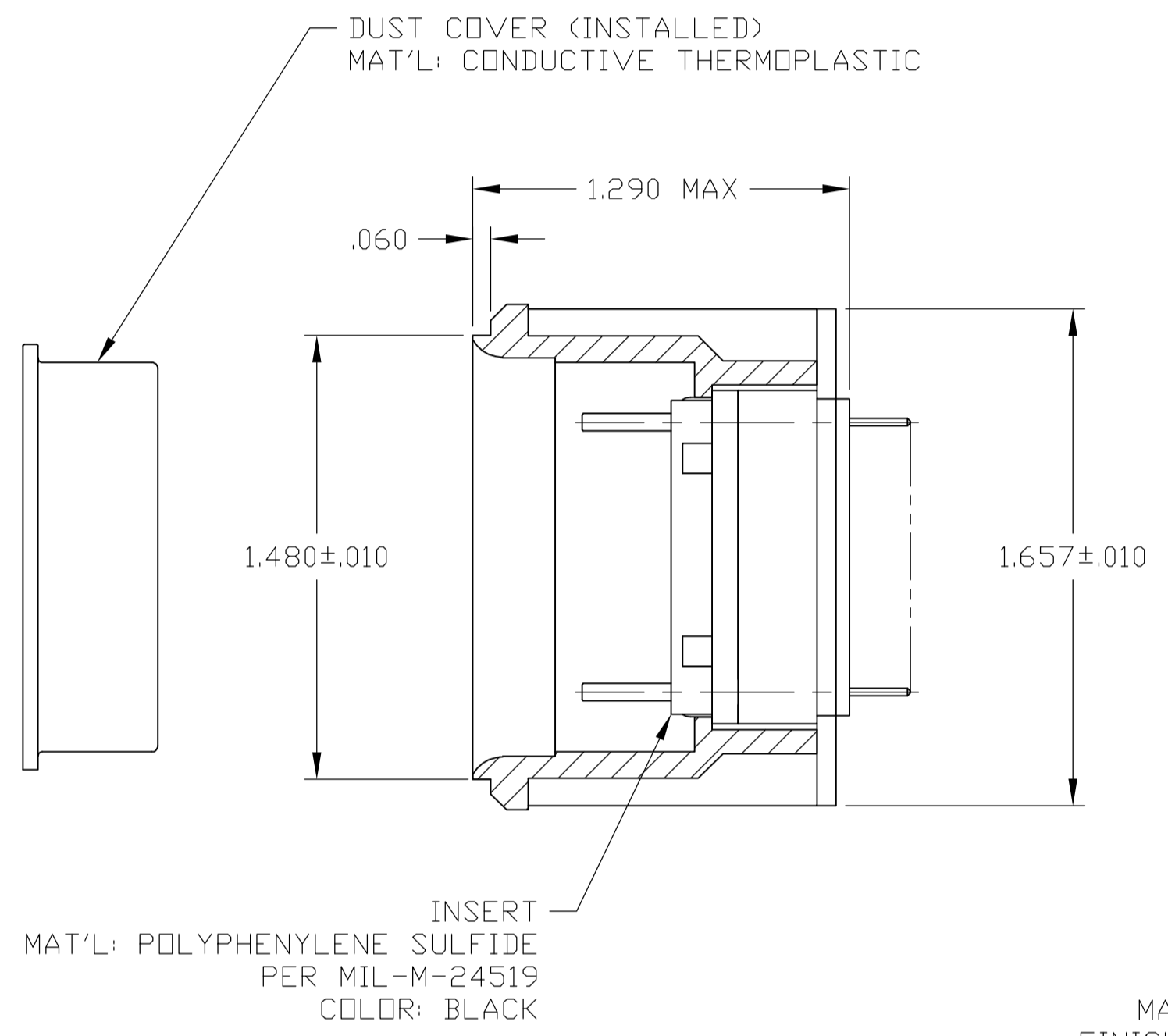
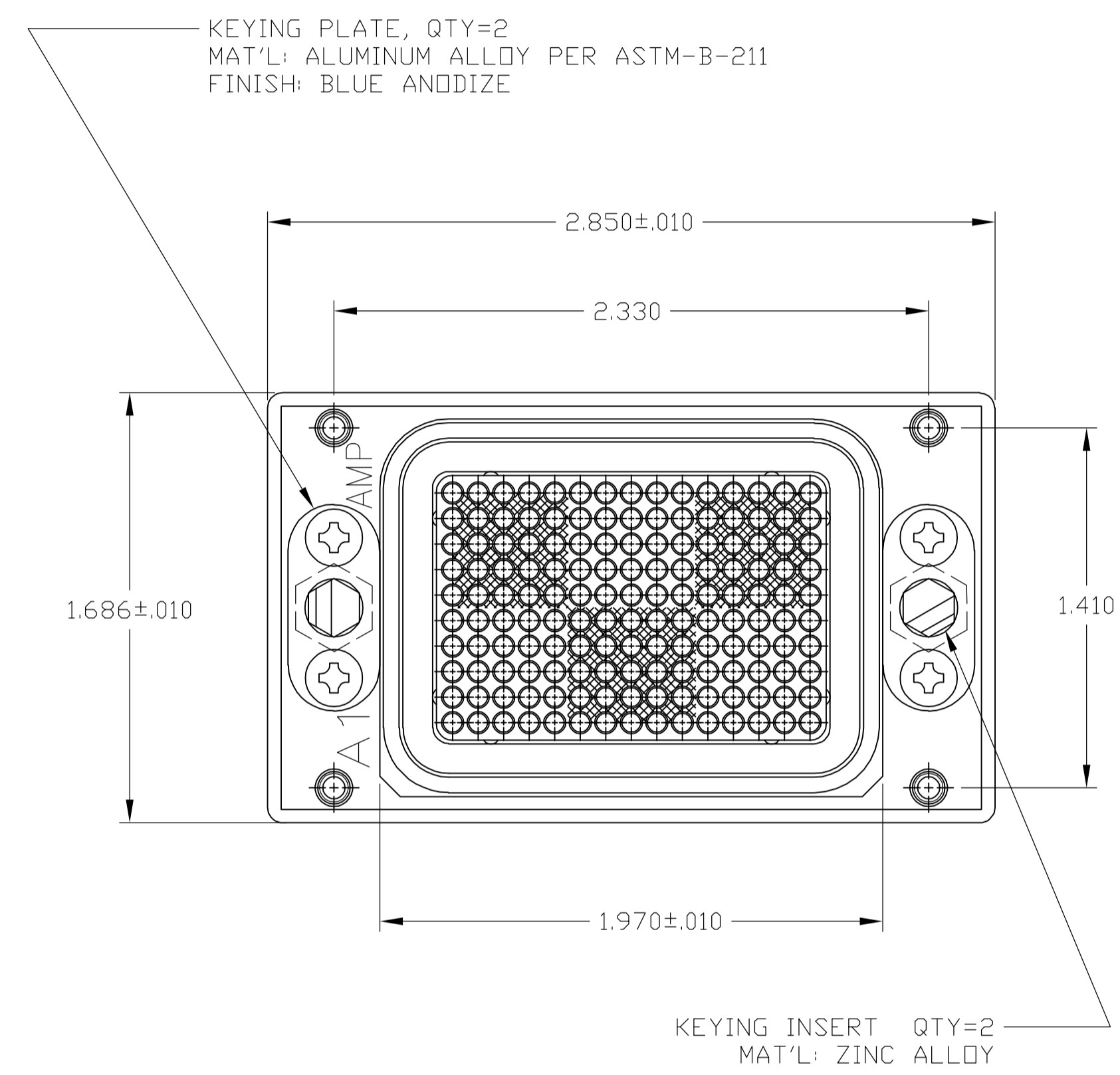

- KEYING ASSEMBLED IN POSITION PER TABLE. FOR KEYING "00" HARDWARE IS SUPPLIED UNASSEMBLED.
- CONTACT PART NUMBERS LOADED IN CONNECTOR: (-1 ONLY)
 (SOLDER POSTS ARE SOLDER COATED)
 SIZE 22 SOCKET CONTACT (150) AMP P/N 1-211431-3.

KEYING POSITION	REMARKS	PART NO.
00	-	1484791-2
10		1484791-1

THIS DRAWING IS A CONTROLLED DOCUMENT.

DIMENSIONS: INCHES	TOLERANCES UNLESS OTHERWISE SPECIFIED:	DWN: C.C.THOMAS 16MAY2002	Tyco Electronics Corporation Harrisburg, Pa. 17105
0 PLC ± - 1 PLC ± - 2 PLC ± - 3 PLC ± .005 4 PLC ± - ANGLES ± -	FINISH SEE CALLOUTS	CHK: S.GLATFELTER 5-17-02 APVD: S.GLATFELTER 5-17-02 PRODUCT SPEC APPLICATION SPEC	
MATERIAL SEE CALLOUTS	FINISH SEE CALLOUTS	WEIGHT -	RCPT ASSY,SINGLE MOD,FRONT RELEASE 150 POSN,ARINC 600 SIZE: A1 CAGE CODE: 00779 DRAWING NO: 1484791 CUSTOMER DRAWING SCALE: 2:1 SHEET 1 OF 1 REV C