

QW030xx DUAL Series Power Modules: dc-dc Converters; 18 Vdc to 36 Vdc or 36 Vdc to 75 Vdc Inputs



The QW030-Series Power Modules use advanced, surface-mount technology and deliver high-quality, efficient, and compact dc-dc conversion.

Applications

- Distributed power architectures
- Workstations
- Computer equipment
- Communications equipment
- Optical transport equipment

Options

- Heat sinks available for extended operation
- Choice of remote on/off logic configurations
- Choice of two pin lengths

Description

The QW030-Series Power Modules are dc-dc converters that operate over an input voltage range of 36 Vdc to 75 Vdc and provide precisely regulated dc outputs. The outputs are fully isolated from the inputs, allowing versatile polarity configurations and grounding connections. The modules have maximum power ratings of 30 W to 36 W at a typical full-load efficiency of up to 88%.

These encapsulated modules offer a metal case for optimum thermal performance. Threaded-through holes are provided to allow easy mounting or addition of a heat sink for high-temperature applications. The standard feature set includes remote sensing, output trim, and remote on/off for convenient flexibility in distributed power applications.

Features

- Small size: 36.8 mm x 57.9 mm x 12.7 mm (1.45 in. x 2.28 in. x 0.50 in.)
- High power density
- High efficiency: 88% typical
- Low output noise
- Constant frequency
- Industry-standard pinout
- Metal case
- 2:1 input voltage range
- Overvoltage and overcurrent protection
- Remote on/off
- Adjustable output voltage
- ISO* 9001 and ISO 14001 Certified manufacturing facilities
- UL† 60950 Recognized, CSA‡ C22.2 No. 60950-00 Certified, VDE§ 0805 (IEC60950) Licensed
- CE mark meets 73/23/EEC and 93/68/EEC directives**

* ISO is a registered trademark of the International Organization for Standardization.

† UL is a registered trademark of Underwriters Laboratories, Inc.

‡ CSA is a registered trademark of Canadian Standards Assn.

§ VDE is a trademark of Verband Deutscher Elektrotechniker e.V.

**This product is intended for integration into end-use equipment.

All the required procedures for CE marking of end-use equipment should be followed. (The CE mark is placed on selected products.)

Absolute Maximum Ratings

Stresses in excess of the absolute maximum ratings can cause permanent damage to the device. These are absolute stress ratings only. Functional operation of the device is not implied at these or any other conditions in excess of those given in the operations sections of the data sheet. Exposure to absolute maximum ratings for extended periods can adversely affect device reliability.

Parameter	Device	Symbol	Min	Max	Unit
Input Voltage: Continuous	QW030xx	I V_I	—	80	Vdc
Transient (100 ms)	QW030xx	$V_{I, trans}$	—	100	V
Operating Case Temperature (See Thermal Considerations section.)	QW030xx	T_c	-40	105*	°C
Storage Temperature	QW030xx	T_{stg}	-55	125	°C
I/O Isolation Voltage (Note case is tied to input)	QW030xx	—	—	1500	Vdc

* Maximum case temperature varies based on power dissipation. See power derating curves for details.

Electrical Specifications

Unless otherwise indicated, specifications apply over all operating input voltage, resistive load, and temperature conditions.

Table 1. Input Specifications

Parameter	Device	Symbol	Min	Typ	Max	Unit
Operating Input Voltage: QW030xx	QW030xx	V_I	36	48	75	Vdc
Maximum Input Current ($V_I = 0$ V to 75 V; $I_o = I_{o, max}$): QW030xx	QW030xx	$I_{I, max}$	—	—	2.2	A
Inrush Transient	QW030xx	i^2t	—	—	0.2	A ² s
Input Reflected-ripple Current, Peak-to-peak (5 Hz to 20 MHz, 12 μ H source impedance; see Test Configurations section.)	QW030xx	I	—	15	—	mAp-p
Input Ripple Rejection (120 Hz)	QW030xx	—	—	50	—	dB

Fusing Considerations

CAUTION: This power module is not internally fused. An input line fuse must always be used.

This encapsulated power module can be used in a wide variety of applications, ranging from simple stand-alone operation to an integrated part of a sophisticated power architecture. To preserve maximum flexibility, internal fusing is not included; however, to achieve maximum safety and system protection, always use an input line fuse. The safety agencies require a normal-blow fuse with a maximum rating of 5 A (see Safety Considerations section). Based on the information provided in this data sheet on inrush energy and maximum dc input current, the same type of fuse with a lower rating can be used. Refer to the fuse manufacturer's data for further information.

Electrical Specifications (continued)

Table 2. Output Specifications

Parameter	Device Suffix	Symbol	Min	Typ	Max	Unit
Output Voltage Set Point ($V_I = 48\text{ V}$; $I_{O1} = I_{O2} = I_{O,min}$)	CL	$V_{O1, set}$	14.7	—	15.3	Vdc
	CL	$V_{O2, set}$	-14.7	—	-15.3	Vdc
	BK	$V_{O1, set}$	11.76	—	12.24	Vdc
	BK	$V_{O2, set}$	-11.76	—	-12.24	Vdc
	AJ	$V_{O1, set}$	4.85	—	5.15	Vdc
	AJ	$V_{O2, set}$	-4.85	—	-5.15	Vdc
Output Voltage (Over all operating input voltage, resistive load, and temperature conditions until end of life. See Test Configurations section.)	CL	V_{O1}	13.8	—	16.2	Vdc
	CL	V_{O2}	-13.8	—	-16.2	Vdc
	BK	V_{O1}	11.04	—	12.96	Vdc
	BK	V_{O2}	-11.04	—	-12.96	Vdc
	AJ	V_{O1}	4.75	—	5.25	Vdc
	AJ	V_{O2}	-4.75	—	-5.25	Vdc
Output Voltage Regulation Line ($V_I = V_{I,min}$ to $V_{I,max}$; $I_{O1}=I_{O2}$) Load ($V_I = V_{I,nom}$; $I_{O1} = I_{O1min}$ to $I_{tot}/2$ and $I_{O2} = I_{O2min}$ to $I_{tot}/2$) Cross Regulation V_{O1}, V_{O2} ($V_I=V_{I,nom}$; I_{O1} or I_{O2} = other output = max load) Temperature ($T_c = -40$ to 100)	Qx030xx	V_{O1}, V_{O2} $V_{O1}+V_{O2}$		0.5 0.25	0.75 0.5	%
	Qx030xx	$V_{O1}+V_{O2}$ V_{O1}, V_{O2}		0.25 1	0.5 2	% %
	Qx030xx	V_{O1}, V_{O2}		± 4	± 6	%
	Qx030xx	V_{O1}, V_{O2}		0.5	1	%
Output Ripple and Noise Voltage (See Test Configurations section.): Measured across one 2.2 μF ceramic capacitor: RMS Peak-to-peak (5 Hz to 20 MHz)	CL	—	—		50	mVrms
	CL	—	—		150	mVp-p
	BK	—	—		40	mVrms
	BK	—	—		120	mVp-p
	AJ	—	—		50	mVrms
	AJ	—	—		150	mVp-p
External Load Capacitance on each output	Qx030xx	—	0	—	220	μF
Output Current (At $I_O < I_{O,min}$ the module may exceed the ripple specifications)	CL	I_{O1}	0.25	—	1.75	A
	CL	I_{O2}	0.25	—	1.75	A
	CL	I_{tot}^\dagger	0.5	—	2.0	A
	BK	I_{O1}	0.25	—	2.5	A
	BK	I_{O2}	0.25	—	2.5	A
	BK	I_{tot}^\dagger	0.5	—	3.0	A
	AJ	I_{O1}	0.25	—	3	A
	AJ	I_{O2}	0.25	—	3	A
	AJ	I_{tot}^\dagger	0.5	—	6	A
Output Current-limit Inception ($V_O = 90\%$ of $V_{O, set}$)	CL	I_{tot}	—	3.0	—	A
	BK	I_{tot}	—	3.7	—	A
	AJ	I_{tot}	—	7	—	A
Output Short-circuit Current ($V_O = 0.25\text{ V}$)	CL	I_{totsc}	—	4.5	—	A
	BK	I_{totsc}	—	5.5	—	A
	AJ	I_{totsc}	—	10	—	A

* Engineering estimate.

† $I_{tot} = I_{O1}+I_{O2}$ Sum should not exceed this number

Electrical Specifications (continued)

Table 2. Output Specifications (continued)

Parameter	Device Suffix	Symbol	Min	Typ	Max	Unit
Efficiency ($V_I = 48\text{ V}$; $I_O = I_{O, \text{max}}$): $T_A = 25\text{ }^\circ\text{C}$ $T_C = 25\text{ }^\circ\text{C}$	CL	η	—	88	—	%
	BK	η	—	88	—	%
	AJ	η	—	85	—	%
Switching Frequency	QW030xx	—	—	360	—	kHz
Dynamic Response ($\Delta I_O/\Delta t = 1\text{ A}/10\text{ }\mu\text{s}$, $V_I = 48\text{ V}$, $T_C = 25\text{ }^\circ\text{C}$):						
Load Change from $I_O = 50\%$ to 75% of $I_{O, \text{max}}$: Peak Deviation	QW030xx	—	—	2.5	—	% $V_{O, \text{set}}$
Settling Time ($V_O < 10\%$ of peak deviation)	QW030xx	—	—	5.0	—	ms
Load Change from $I_O = 50\%$ to 25% of $I_{O, \text{max}}$: Peak Deviation	QW030xx	—	—	2.5	—	% $V_{O, \text{set}}$
Settling Time ($V_O < 10\%$ of peak deviation)	QW030xx	—	—	5.0	—	ms

* Engineering estimate.

Table 3. Isolation Specifications

Parameter	Device	Min	Typ	Max	Unit
Isolation Capacitance (engineering estimate)	QW030xx	—	600	—	pF
Isolation Resistance	QW030xx	10	—	—	M Ω

Table 4. General Specifications

Parameter	Device	Min	Typ	Max	Unit
Calculated MTBF ($I_O = 80\%$ of $I_{O, \text{max}}$; $T_C = 40\text{ }^\circ\text{C}$)	QW030xx	5,000,000			hours
Weight	QW030xx	—	—	75 (2.7)	g (oz.)

Feature Specifications

Unless otherwise indicated, specifications apply over all operating input voltage, resistive load, and temperature conditions. See Feature Descriptions section of this data sheet for additional information.

Parameter	Device Suffix	Symbol	Min	Typ	Max	Unit
<p>Remote On/Off Signal Interface ($V_I = V_{I, \min}$ to $V_{I, \max}$; open collector or equivalent compatible; signal referenced to $V_I(-)$ terminal.): Negative Logic: Device Code Suffix "1": Logic Low—Module On Logic High—Module Off Positive Logic: If Device Code Suffix "1" Is Not Specified: Logic Low—Module Off Logic High—Module On Module Specifications: On/Off Current—Logic Low On/Off Voltage: Logic Low Logic High ($I_{on/off} = 0$ mA) Open Collector Switch Specifications: Leakage Current During Logic High ($V_{on/off} = 15$ V) Output Low Voltage During Logic Low ($I_{on/off} = 1$ mA)</p>	All	$I_{on/off}$	—	—	1.0	mA
	All	$V_{on/off}$	-0.7	—	1.2	V
	All	$V_{on/off}$	—	—	15	V
	All	$I_{on/off}$	—	—	50	μ A
	All	$V_{on/off}$	—	—	1.2	V
<p>Turn-on Delay and Rise Times (at 80% of $I_{O, \max}$; $T_A = 25$ °C): Case 1: On/Off Input Is Set for Logic High and then Input Power Is Applied (delay from point at which $V_I = V_{I, \min}$ until $V_O = 10\%$ of $V_{O, \text{nom}}$). Case 2: Input Power Is Applied for at Least One Second, and Then the On/Off Input Is Set to Logic High (delay from point at which $V_{on/off} = 0.9$ V until $V_O = 10\%$ of $V_{O, \text{nom}}$). Output Voltage Rise Time (time for V_O to rise from 10% of $V_{O, \text{nom}}$ to 90% of $V_{O, \text{nom}}$) Output Voltage Overshoot (at 80% of $I_{O, \max}$; $T_A = 25$ °C)</p>	All	T_{delay}	—	8	—	ms
	All	T_{delay}	—	2	—	ms
	All	T_{rise}	—	10	—	ms
	All	—	—	—	5*	%
<p>Output Voltage Adjustment (See Feature Descriptions section.): Output Voltage Set-point Adjustment Range (trim)</p>	QW030xx	—	75	—	110	% $V_{O, \text{nom}}$
Output Overvoltage Protection (clamp)	CL	$V_{O1, \text{ovp}}$	17.1	—	22.5	V
	CL	$V_{O2, \text{ovp}}$	-17.1	—	-22.5	V
	BK	$V_{O1, \text{ovp}}$	13.7	—	18.0*	V
	BK	$V_{O2, \text{ovp}}$	-13.7	—	-18.0*	V
	AJ	$V_{O1, \text{ovp}}$	5.9	—	7	V
	AJ	$V_{O2, \text{ovp}}$	-5.9	—	-7	V

* Engineering estimate.

Feature Specifications (continued)

Parameter	Device Suffix	Symbol	Min	Typ	Max	Unit
Overtemperature Protection ($V_i = 75\text{ V}$, $I_{tot} = 3\text{ A}$, see Figure 28.):	QW030xx	T_{case}	—	115	—	°C
Undervoltage Lockout: QW030xx	QW030xx	—	—	27	—	V

* Engineering estimate.

Test Configurations

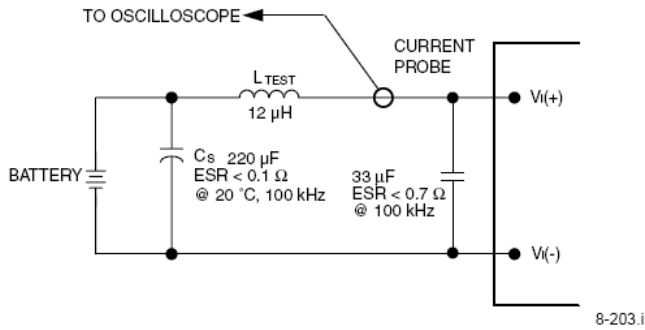

Note: Measure input reflected-ripple current with a simulated source inductance (LTEST) of 12 µH. Capacitor Cs offsets possible battery impedance. Measure current as shown above.

Figure 1. QW030-Series Input Reflected-Ripple Test Setup

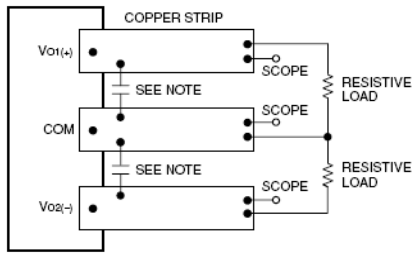

Note: Use the capacitor(s) referenced in the Output Ripple and Noise Voltage specifications in the Output Specifications table. Scope measurement should be made using a BNC socket. Position the load between 51 mm and 76 mm (2 in. and 3 in.) from the module.

Figure 2. QW030-Series Peak-to-Peak Output Noise Measurement Test Setup

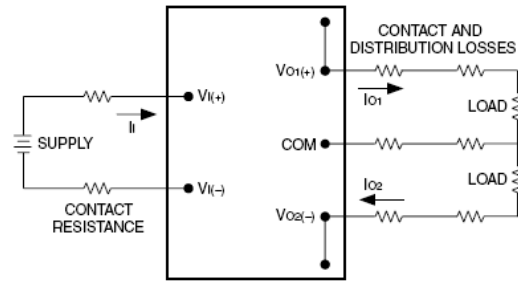

Note: All measurements are taken at the module terminals. When socketing, place Kelvin connections at module terminals to avoid measurement errors due to socket contact resistance.

$$\eta = \frac{\sum_{j=1}^2 | [V_{Oj(+)} - V_{COM}] I_{Oj} |}{[V_{I(+)} - V_{I(-)}] I_I} \times 100 \quad \%$$

Figure 3. QW030-Series Output Voltage and Efficiency Measurement Test Setup

Design Considerations

Grounding Considerations

For the QW modules, the case is internally connected to the $V_I(+)$ pin.

Input Source Impedance

The power module should be connected to a low ac-impedance input source. Highly inductive source impedances can affect the stability of the power module. If the input source inductance exceeds $4\ \mu\text{H}$, a $33\ \mu\text{F}$ electrolytic capacitor (ESR $< 0.7\ \text{ohm}$ at $100\ \text{kHz}$) mounted close to the power module helps ensure stability of the unit.

Safety Considerations

QW Modules

For safety-agency approval of the system in which the power module is used, the power module must be installed in compliance with the spacing and separation requirements of the end-use safety agency standard, i.e., *UL60950*, *CSA C22.2 No. 60950-00*, and *VDE 0805 (IEC60950)*.

If the input source is non-SELV (ELV or a hazardous voltage greater than 60 Vdc and less than or equal to 75 Vdc), for the module's output to be considered meeting the requirements of safety extra-low voltage (SELV), all of the following must be true:

- The input source is to be provided with reinforced insulation from any hazardous voltages, including the ac mains.
- One V_I pin and one V_O pin are to be grounded, or both the input and output pins are to be kept floating.
- The input pins of the module are not operator accessible.
- Another SELV reliability test is conducted on the whole system, as required by the safety agencies, on the combination of supply source and the subject module to verify that under a single fault, hazardous voltages do not appear at the module's output.

Note: Do not ground either of the input pins of the module without grounding one of the output pins. This may allow a non-SELV voltage to appear between the output pin and ground.

The power module has extra-low voltage (ELV) outputs when all inputs are ELV.

The input to these units is to be provided with a maximum 5 A normal-blow fuse in the ungrounded lead.

Feature Descriptions

Overcurrent Protection

To provide protection in a fault (output overload) condition, the unit is equipped with internal current-limiting circuitry and can endure current limiting for an unlimited duration. At the point of current-limit inception, the unit shifts from voltage control to current control. If the output voltage is pulled very low during a severe fault, the current-limit circuit can exhibit either foldback or tailout characteristics (output-current decrease or increase). The unit operates normally once the output current is brought back into its specified range.

Remote On/Off

Two remote on/off options are available. Positive logic remote on/off turns the module on during a logic-high voltage on the remote ON/OFF pin, and off during a logic low. Negative logic remote on/off, device code suffix "1," turns the module off during logic-high voltage and on during a logic low.

To turn the power module on and off, the user must supply a switch to control the voltage between the on/off terminal and the $V_I(-)$ terminal ($V_{on/off}$). The switch may be an open collector or equivalent (see Figure 4). A logic low is $V_{on/off} = -0.7\ \text{V}$ to $1.2\ \text{V}$. The maximum $I_{on/off}$ during a logic low is 1 mA. The switch should maintain a logic-low voltage while sinking 1 mA.

During a logic high, the maximum $V_{on/off}$ generated by the power module is 15 V. The maximum allowable leakage current of the switch at $V_{on/off} = 15\ \text{V}$ is 50 μA .

Feature Descriptions (continued)

Remote On/Off (continued)

If not using the remote on/off feature, do one of the following:

For positive logic, leave the ON/OFF pin open.

For negative logic, short the ON/OFF pin to $V_I(-)$.

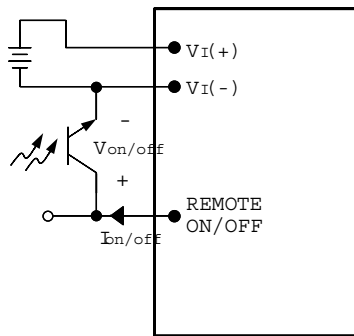

8-758(C).a

Figure 4. QW030-Series Remote On/Off Implementation

Output Voltage Set-Point Adjustment (Trim)

Output voltage trim allows the user to increase or decrease the output voltage set point of a module. This is accomplished by connecting an external resistor between the TRIM pin and either the $V_{O1}(+)$ or $V_{O2}(-)$ pins. The trim resistor should be positioned close to the module.

If not using the trim feature, leave the TRIM pin open.

With an external resistor between the TRIM and $V_{O1}(+)$ pins (R_{adj-up}), the output voltage set point ($V_{O, adj}$) increases (see Figure 5). The following equation determines the required external-resistor value to obtain a change in output voltage from $V_{O, nom}$ to $V_{O, adj}$.

$$R_{adj-up} = \left[\frac{V_{O,adj}}{V_{O,adj} - V_{O,nom}} \cdot \left(\frac{2 \times V_{O,nom}}{1.225} - 1 \right) 10000 \right] - 1000$$

With an external resistor connected between the TRIM and $V_{O2}(-)$ pins ($R_{adj-down}$), the output voltage set point ($V_{O, adj}$) decreases (see Figure 6).

The following equation determines the required external-resistor value to obtain a change in output voltage from $V_{O, nom}$ to $V_{O, adj}$.

$$R_{adj-down} = \left(\frac{10000 \times V_{O,adj}}{V_{O,nom} - V_{O,adj}} \right) - 1000$$

The voltage between the $V_{O1}(+)$ and Com., and $V_{O2}(-)$ and Com. terminals must not exceed the minimum output overvoltage protection value shown in the Feature Specifications table. This limit includes any increase in voltage due to remote-sense compensation and output voltage set-point adjustment (trim). See Figure 5.

Consult your Lineage Power Account Manager or Application Engineer if the output voltage needs to be increased more than the above limitation.

The amount of power delivered by the module is defined as the voltage at the output terminals multiplied by the output current. When using trim, the output voltage of the module can be increased, which at the same output current would increase the power output of the module. Care should be taken to ensure that the maximum output power of the module remains at or below the maximum rated power.

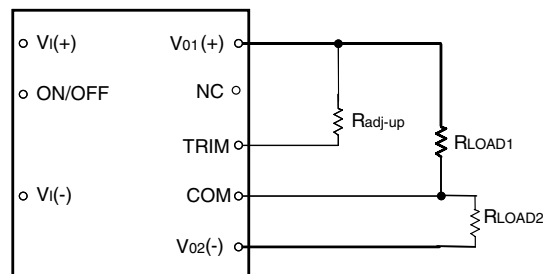

8-715.v

Figure 5. QW030-Series Circuit Configuration to Increase Output Voltage

Feature Descriptions (continued)

Output Voltage Set-Point Adjustment (Trim)(continued)

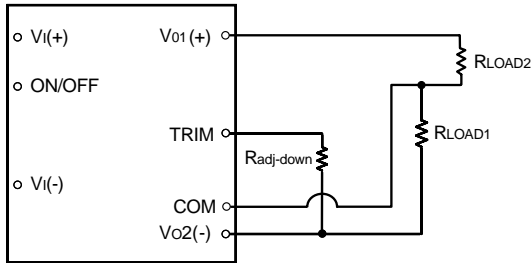

8-715.vf

Figure 6. QW030-Series Circuit Configuration to Decrease Output Voltage

Output Overvoltage Protection

The output overvoltage clamp consists of control circuitry, independent of the primary regulation loop, that monitors the voltage on the output terminals. This control loop has a higher voltage set point than the primary loop (see the Feature Specifications table). In a fault condition, the overvoltage clamp ensures that the output voltage does not exceed $V_{O, clamp, max}$. This provides a redundant voltage-control that reduces the risk of output overvoltage.

Overtemperature Protection

These modules feature overtemperature protection to safeguard the modules against thermal damage.

When the temperature exceeds the overtemperature threshold given in the feature specifications table, the module will limit the available output current in order to help protect against thermal damage. The overcurrent inception point will gradually move back to its original level as the module is cooled below the overtemperature threshold.

Input Undervoltage Lockout

At input voltages below the input undervoltage lockout limit, the module operation is disabled. The module will begin to operate at an input voltage between the undervoltage lockout limit and the minimum operating input voltage.

Thermal Considerations

Introduction

The power modules operate in a variety of thermal environments; however, sufficient cooling should be provided to help ensure reliable operation of the unit. Heat-dissipating components inside the unit are thermally coupled to the case. Heat is removed by conduction, convection, and radiation to the surrounding environment. Proper cooling can be verified by measuring the case temperature. The case temperature should be measured at the position indicated in Figure 7.

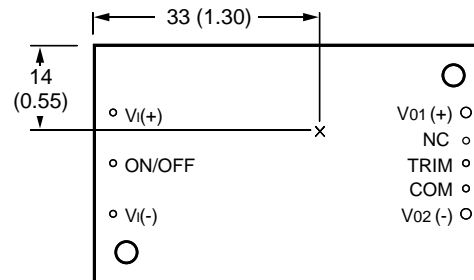

8-2104.a

Note: Top view, pin locations are for reference only. Measurements shown in millimeters and (inches).

Figure 7. QW030-Series Case Temperature Measurement Location

The temperature at this location should not exceed 105 °C. The output power of the module should not exceed the rated power for the module as listed in the Ordering Information table.

Although the maximum case temperature of the power modules is 105 °C, you can limit this temperature to a lower value for extremely high reliability.

Thermal Considerations (continued)

Heat Transfer Without Heat Sinks

Increasing airflow over the module enhances the heat transfer via convection. Figures 8 and 10 show the maximum power that can be dissipated by the module without exceeding the maximum case temperature versus local ambient temperature (T_A) for natural convection through 3 m/s (600 ft./min.).

Systems in which these power modules may be used typically generate natural convection airflow rates of 0.3 ms^{-1} (60 ft./min.) due to other heat-dissipating components in the system. Therefore, the natural convection condition represents airflow rates of up to 0.3 ms^{-1} (60 ft./min.). Use of Figure 8 is shown in the following example.

Example

What is the minimum airflow necessary for a QW030BK operating at $V_I = 48 \text{ V}$, an output current of 1.5 A, each and a maximum ambient temperature of 89°C ?

Solution

Given: $V_I = 48 \text{ V}$
 $I_{O1} = 1.5 \text{ A}$, $I_{O2} = 1.5 \text{ A}$
 $T_A = 89^\circ\text{C}$

Determine P_D (Use Figure 9):

$$P_D = 4.5 \text{ W}$$

Determine airflow (v) (Use Figure 8):

$$v = 3.0 \text{ m/s (600 ft./min.)}$$

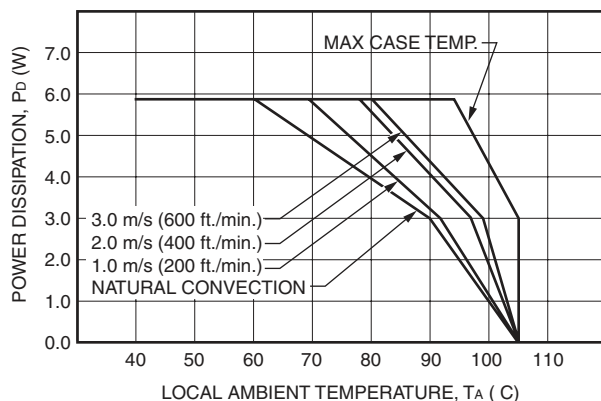

1-0206

Figure 8. QW030BK POWER DERATING CURVE

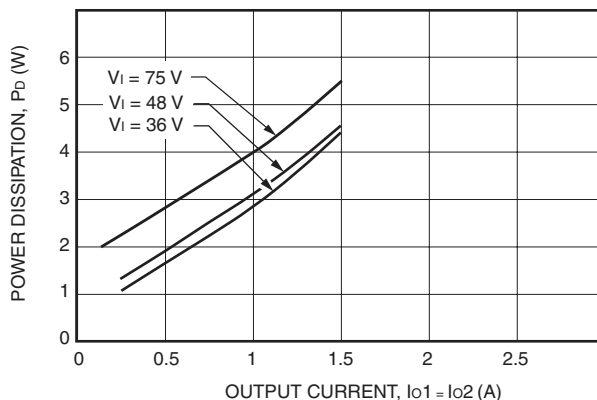

1-0204

Figure 9. QW030BK Power dissipation With Balanced Loads

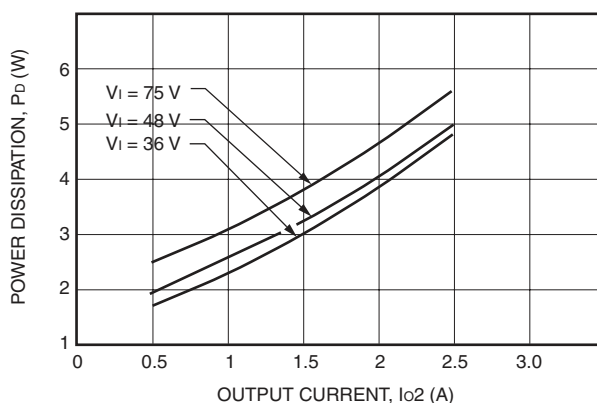

1-0205

Figure 10. QW030BK Power Dissipation with Unbalanced Loads with $I_{O1} = 0.5 \text{ A}$

Thermal Considerations (continued)

Heat Transfer with Heat Sinks

The power modules have through-threaded, M3 x 0.5 mounting holes, which enable heat sinks or cold plates to attach to the module. The mounting torque must not exceed 0.56 N-m (5 in.-lb.). For a screw attachment from the pin side, the recommended hole size on the customer's PWB around the mounting holes is 0.130 ± 0.005 inches. The mounting torque from the pin side must not exceed 0.25 N-m (2.2 in.-lbs.).

Thermal derating with heat sinks is expressed by using the overall thermal resistance of the module. Total module thermal resistance (θ_{ca}) is defined as the maximum case temperature rise ($\Delta T_{C, \max}$) divided by the module power dissipation (P_D):

$$\theta_{ca} = \left[\frac{\Delta T_{C, \max}}{P_D} \right] = \left[\frac{(T_C - T_A)}{P_D} \right]$$

The location to measure case temperature (T_C) is shown in Figure 7. Consult your Lineage Power Account Manager or Application Engineer for case-to-ambient thermal resistance vs. airflow for various heat sink configurations, heights, and orientations. Longitudinal orientation is defined as the long axis of the module that is parallel to the airflow direction, whereas in the transverse orientation, the long axis is perpendicular to the airflow. These curves are obtained by experimental testing of heat sinks, which are offered in the product catalog.

These measured resistances are from heat transfer from the sides and bottom of the module as well as the top side with the attached heat sink; therefore, the case-to-ambient thermal resistances shown are generally lower than the resistance of the heat sink by itself. The module used to collect the data in the case-to-ambient thermal resistance curves had a thermal-conductive dry pad between the case and the heat sink to minimize contact resistance.

Custom Heat Sinks

A more detailed model can be used to determine the required thermal resistance of a heat sink to provide necessary cooling. The total module resistance can be separated into a resistance from case-to-sink (θ_{cs}) and sink-to-ambient (θ_{sa}) as shown in Figure 11.

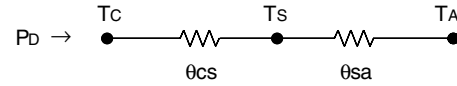

8-1304

Figure 11. QW030-Series Resistance from Case-to-Sink and Sink-to-Ambient

For a managed interface using thermal grease or foils, a value of $\theta_{cs} = 0.1 \text{ } ^\circ\text{C/W}$ to $0.3 \text{ } ^\circ\text{C/W}$ is typical. The solution for heat sink resistance is:

$$\theta_{sa} = \left[\frac{(T_C - T_A)}{P_D} \right] - \theta_{cs}$$

This equation assumes that all dissipated power must be shed by the heat sink. Depending on the user-defined application environment, a more accurate model, including heat transfer from the sides and bottom of the module, can be used. This equation provides a conservative estimate for such instances.

Layout Considerations

Copper paths must not be routed beneath the power module standoffs. For additional layout guidelines, refer to the FLTR100V10 or FLTR100V20 data sheet.

Outline Diagram

Dimensions are in millimeters and (inches).

Tolerances: x.x mm \pm 0.5 mm (x.xx in. \pm 0.02 in.)
x.xx mm \pm 0.25 mm (x.xxx in. \pm 0.010 in.)

Top View

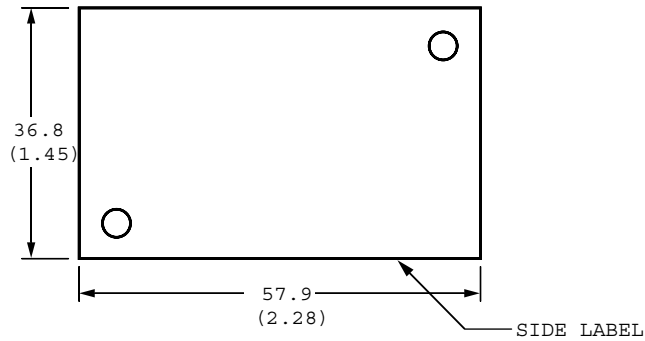

Side View

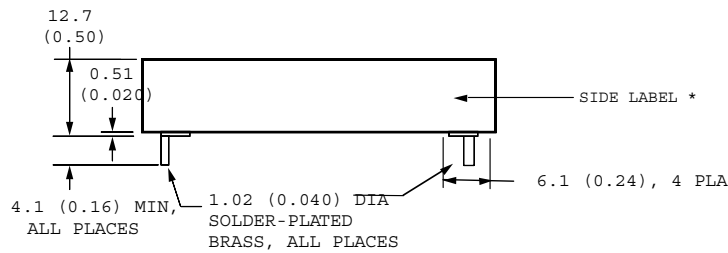

Bottom View

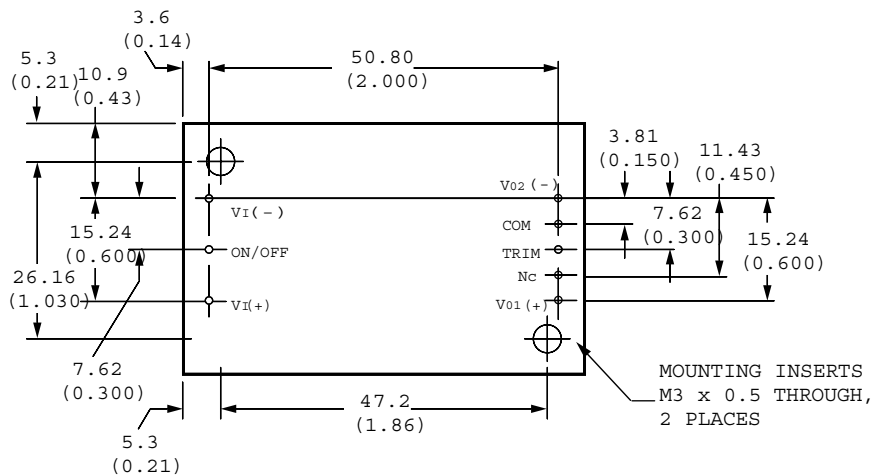

8-1769

* Side label includes Lineage name, product designation, safety agency markings, input/output voltage and current ratings, and bar code.

Recommended Hole Pattern

Component-side footprint.

Dimensions are in millimeters and (inches).

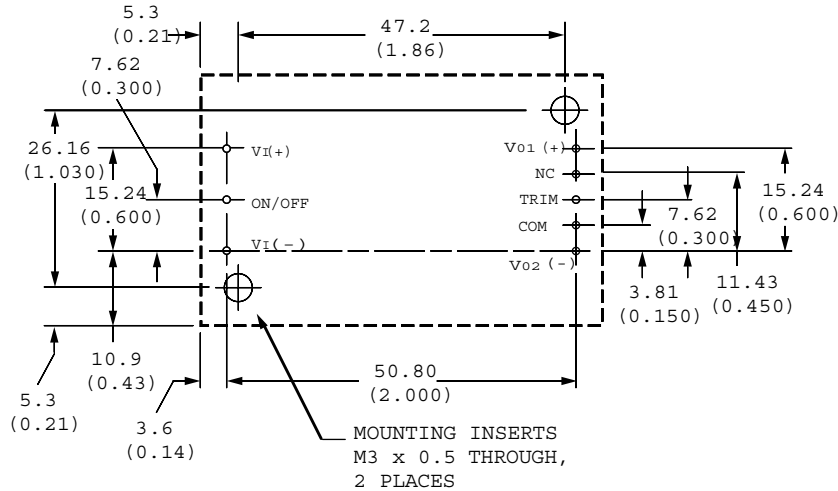

8-1769p2

Ordering Information

Please contact your Lineage Power Account Manager or Field Application Engineer for pricing and availability.

Table 5. Device Codes

Input Voltage	Output Voltage	Output Power	Output Current	Remote On/Off Logic	Device Code	Comcode
48 Vdc	+12, -12	36W	2.5A, 2.5A	Negative	QW030BK1	108958885
48 Vdc	+15, -15	30W	1.75A, 1.75A	Negative	QW030CL1	108962176
48 Vdc	+5, -5	30W	3A, 3A	Negative	QW030AJ1	108963687

Table 6. Device Options

Option	Device Code Suffix
Short pins: 2.79 mm ± 0.25 mm (0.110 in. ± 0.010 in.)	8
Short pins: 3.68 mm ± 0.25 mm (0.145 in. ± 0.010 in.)	6
Negative logic On/Off	1



LINEAGE POWER

World Wide Headquarters

Lineage Power Corporation

3000 Skyline Drive, Mesquite, TX 75149, USA

+1-800-526-7819

(Outside U.S.A.: **+1-972-284-2626**)

www.lineagepower.com

e-mail: techsupport1@lineagepower.com

Asia-Pacific Headquarters

Tel: +65 6 416 4283

Europe, Middle-East and Africa Headquarters

Tel: +49 89 6089 286

India Headquarters

Tel: +91 80 28411633

Lineage Power reserves the right to make changes to the product(s) or information contained herein without notice. No liability is assumed as a result of their use or application. No rights under any patent accompany the sale of any such product(s) or information.

© 2008 Lineage Power Corporation, (Mesquite, Texas) All International Rights Reserved.

October 2008

ADS01-046EPS (Replaces ADS01-045EPS)