

REVISIONS				
P.	LTN.	DESCRIPTION	DATE	APP'D.
C	REV PER ECO	19-013887	9-9-19	CT FB

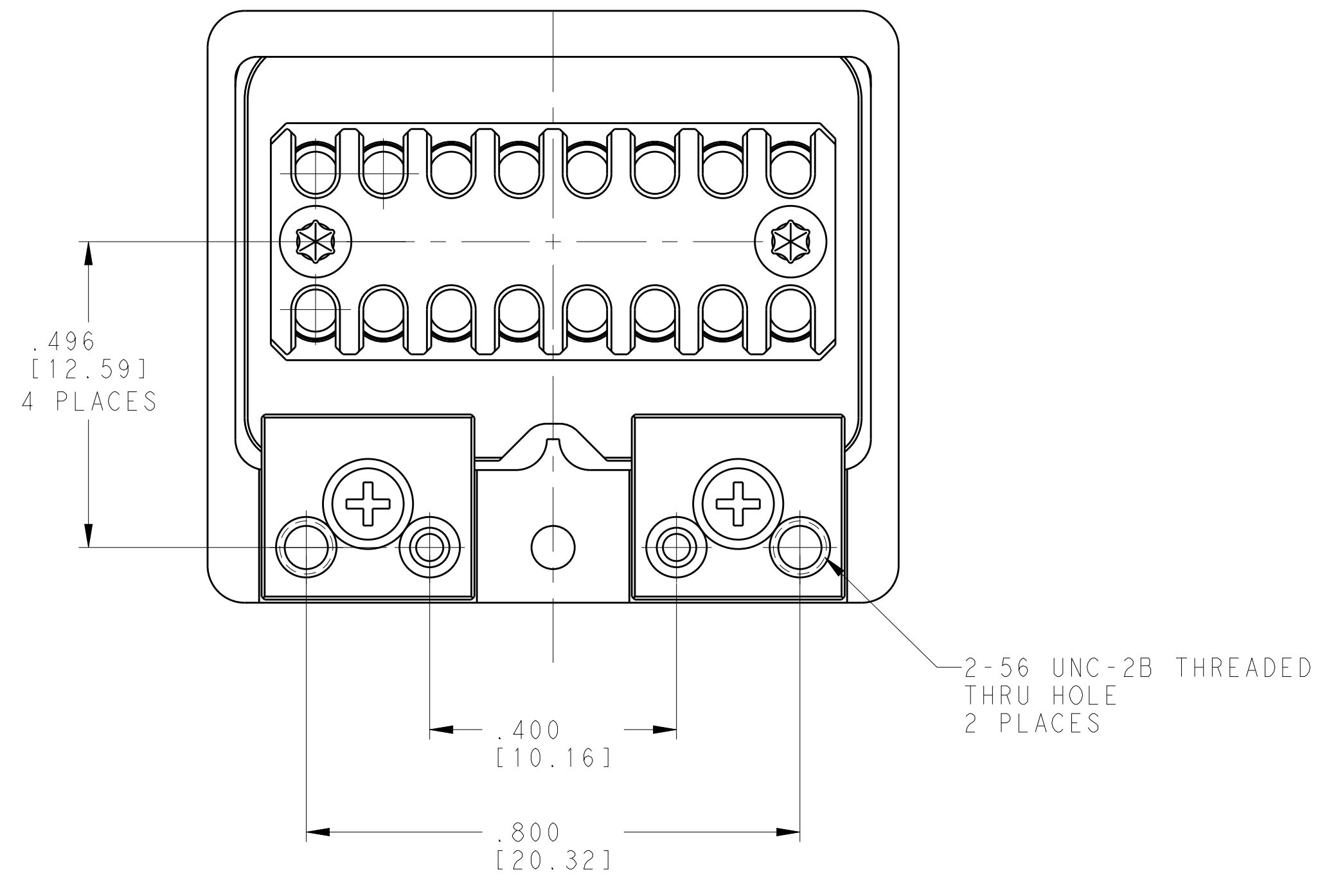
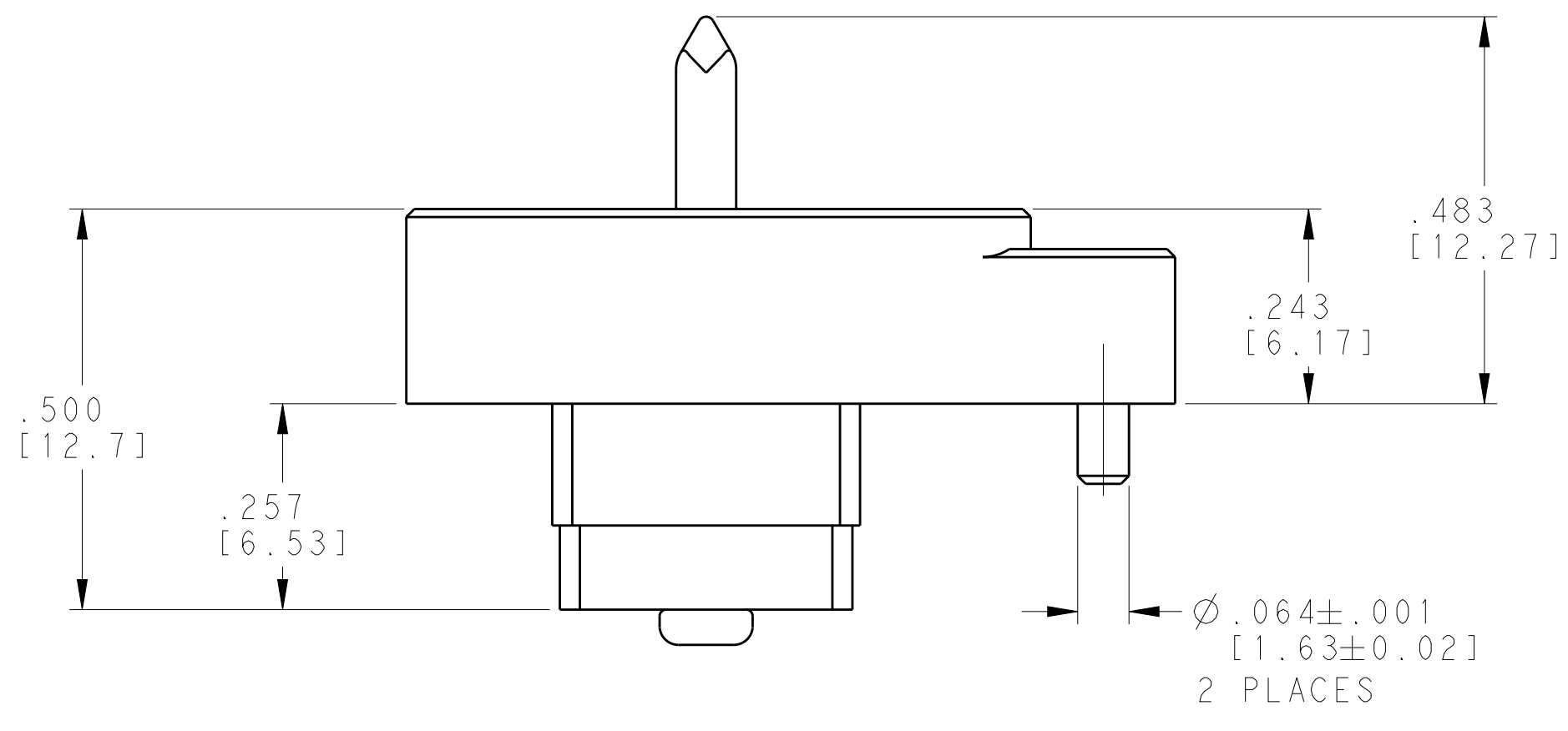
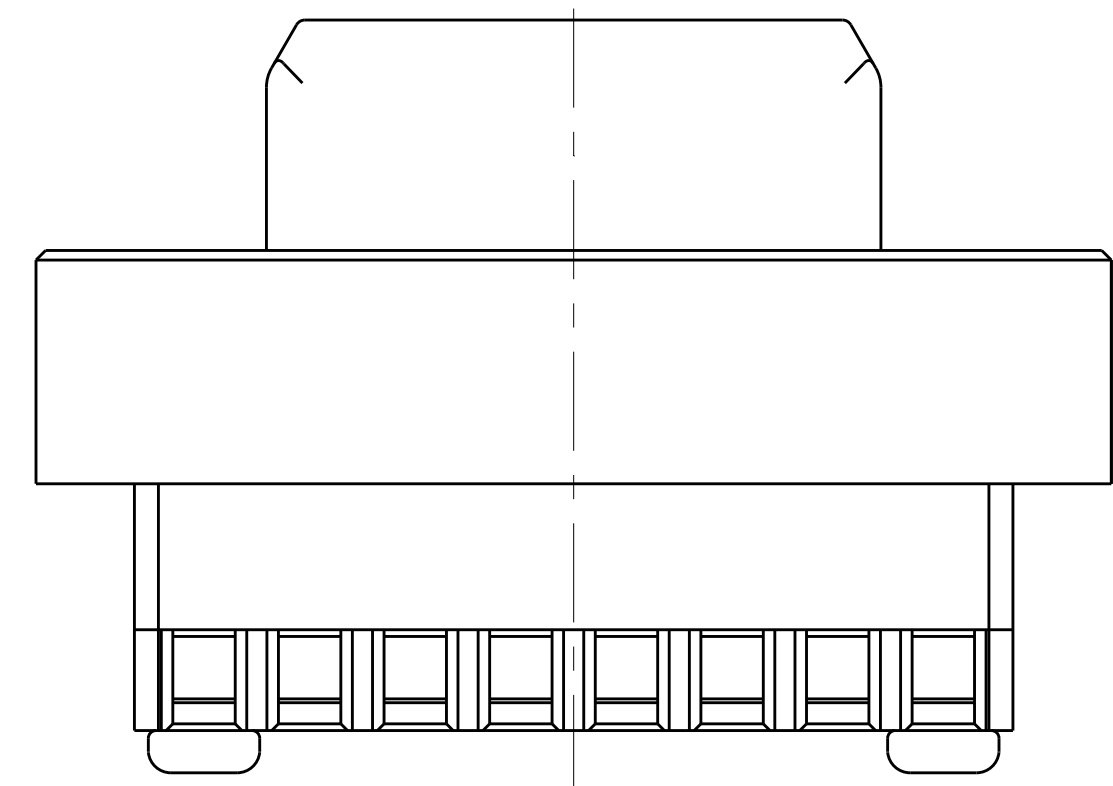
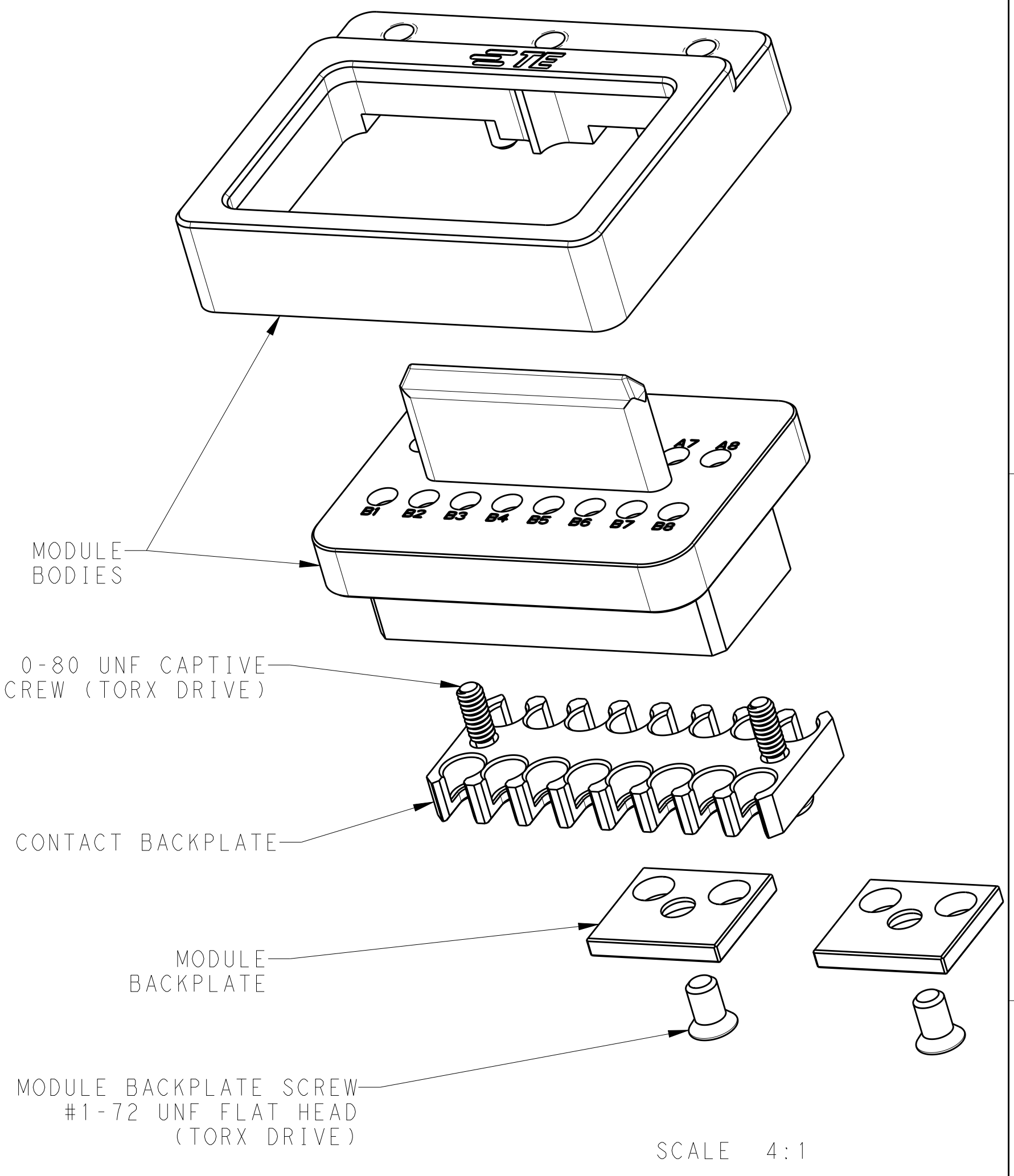
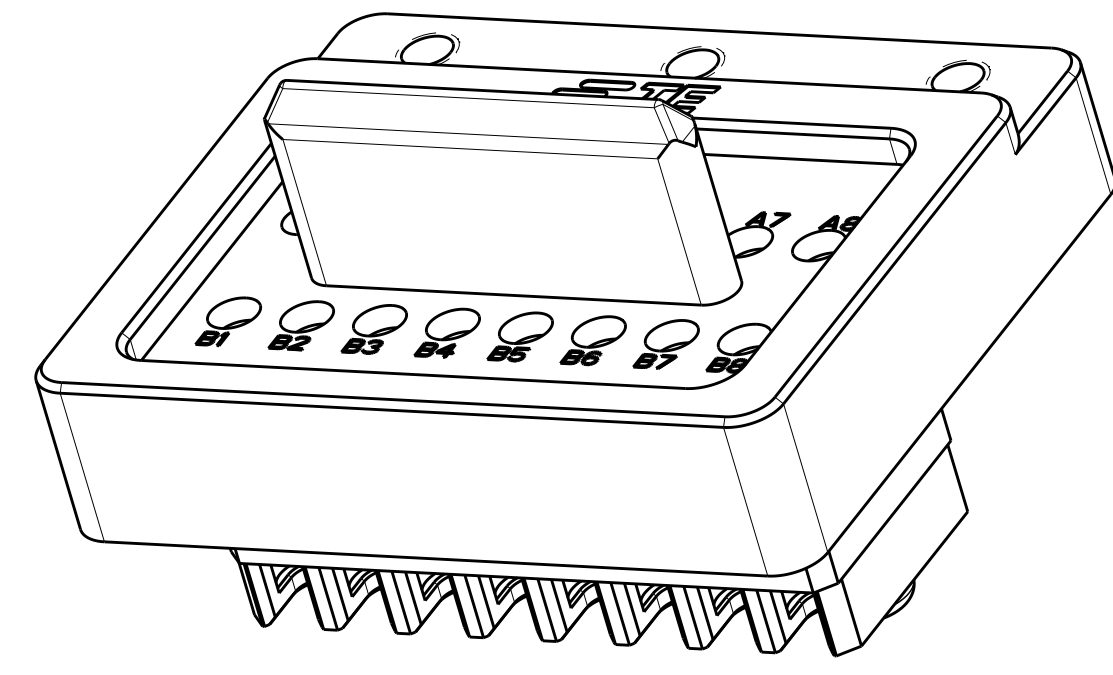
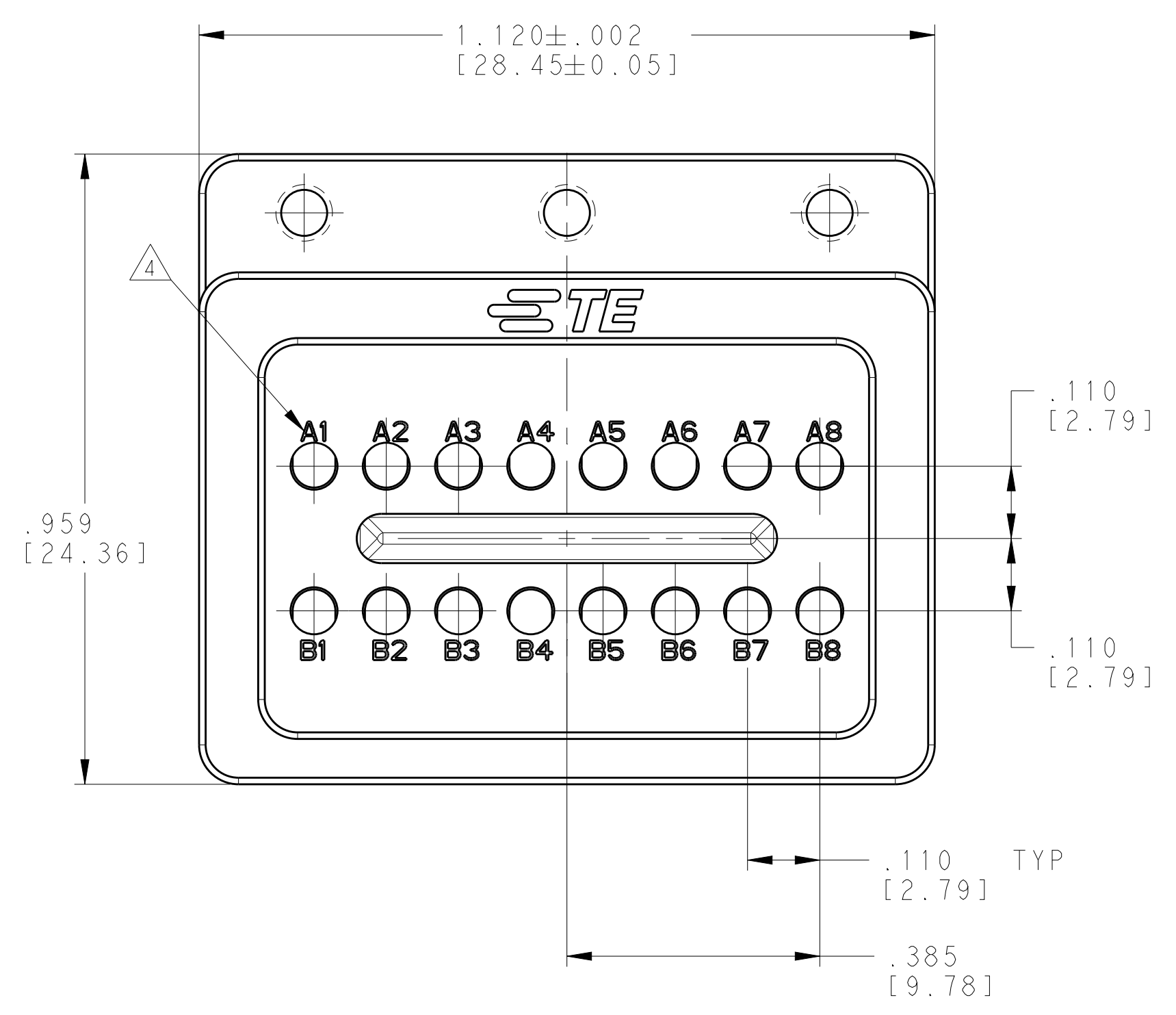

- 1 MATERIAL:  
MODULE BODIES AND BACKPLATES - SEE TABLE  
SCREWS - 300 SERIES STAINLESS STEEL
- 2 FINISH:  
MODULE BODIES - SEE TABLE  
SCREWS - PASSIVATED
- 3. SHIPPED IN KIT FORM. CONTACT BACKPLATE SCREWS TO BE ASSEMBLED TO CONTACT BACKPLATE. MODULE BODIES TO BE ASSEMBLED TOGETHER WITH MODULE BACKPLATE AND MODULE BACKPLATE SCREW.
- 4 CIRCUIT IDENTIFICATION MARKING
- 5. DESIGNED TO BE USED WITH CONTACTS 2302345-1

CLEAR CHROMATE CONVERSION COATING	ALUMINUM ALLOY 7075	2341106-2
PASSIVATED	STAINLESS STEEL PER UNS S30300	2341106-1
MODULE FINISH 2	MODULE MATERIAL 1	PART NUMBER

THIS DRAWING IS A CONTROLLED DOCUMENT.		DWN: L.SIPE 13AUG2018	TE Connectivity
DIMENSIONS: INCHES/mm		CHK: F.BLASICK 13AUG2018	
TOLERANCES UNLESS OTHERWISE SPECIFIED:		APP'D: F.BLASICK 13AUG2018	NAME: 16 POSITION NanoRF MODULE PRODUCT SPEC: P.C.B. MOUNT BACKPLANE APPLICATION SPEC: VITA 67.3C FOOTPRINT COMPATIBLE
0 PLC ± 1 PLC ± 2 PLC ± 3 PLC ±.005(0.13) 4 PLC ± ANGLES ±		SIZE: 408-163016 WEIGHT:	
MATERIAL 1	FINISH 2	CUSTOMER DRAWING	RESTRICTED TO: A100779C=2341106 SCALE: 5:1 SHEET 1 OF 2 REV C

REVISIONS				
P.	LTN	DESCRIPTION	DATE	APVD
-	-	SEE SHEET 1	-	-

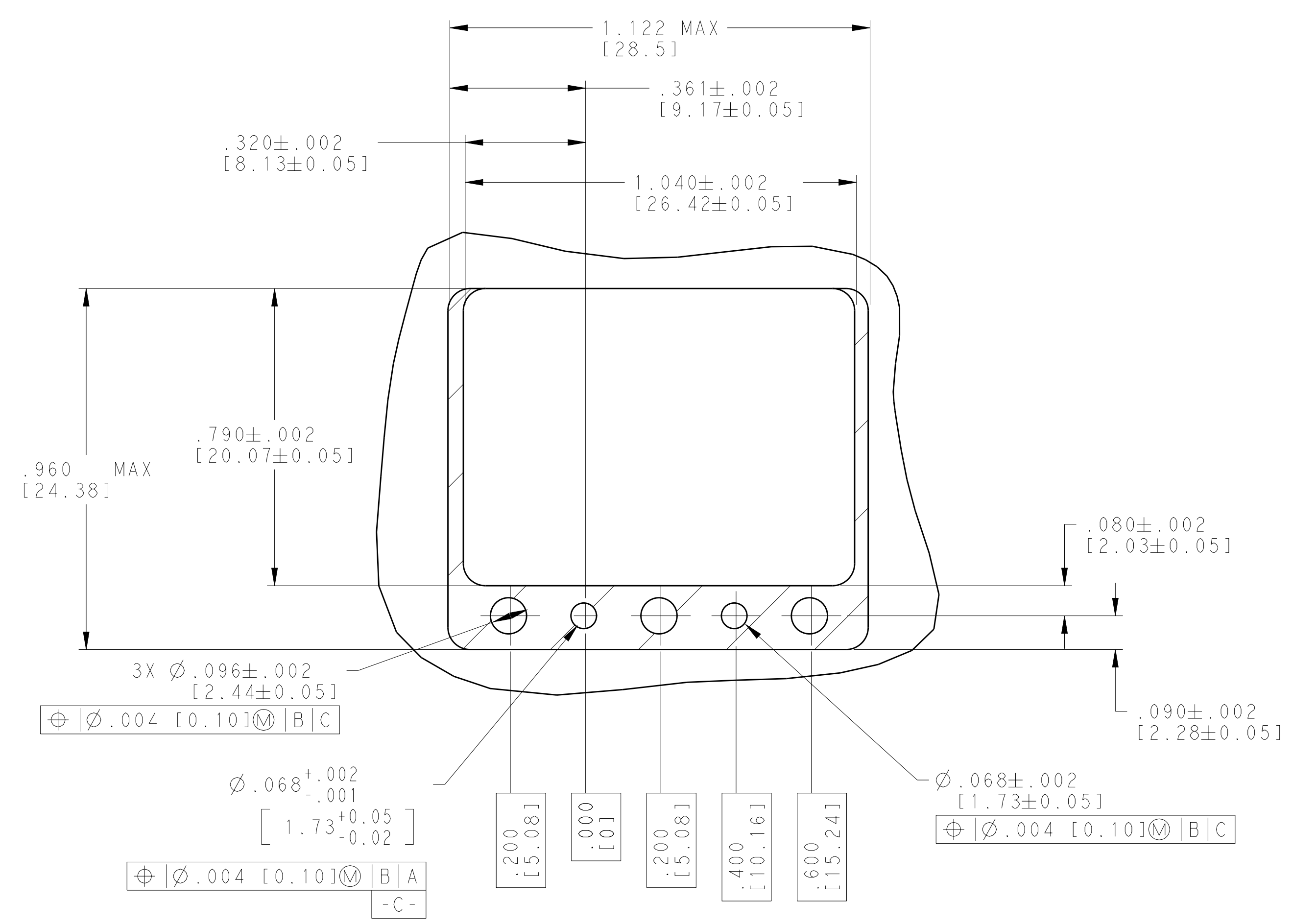

DETAIL D  
SCALE 4:1

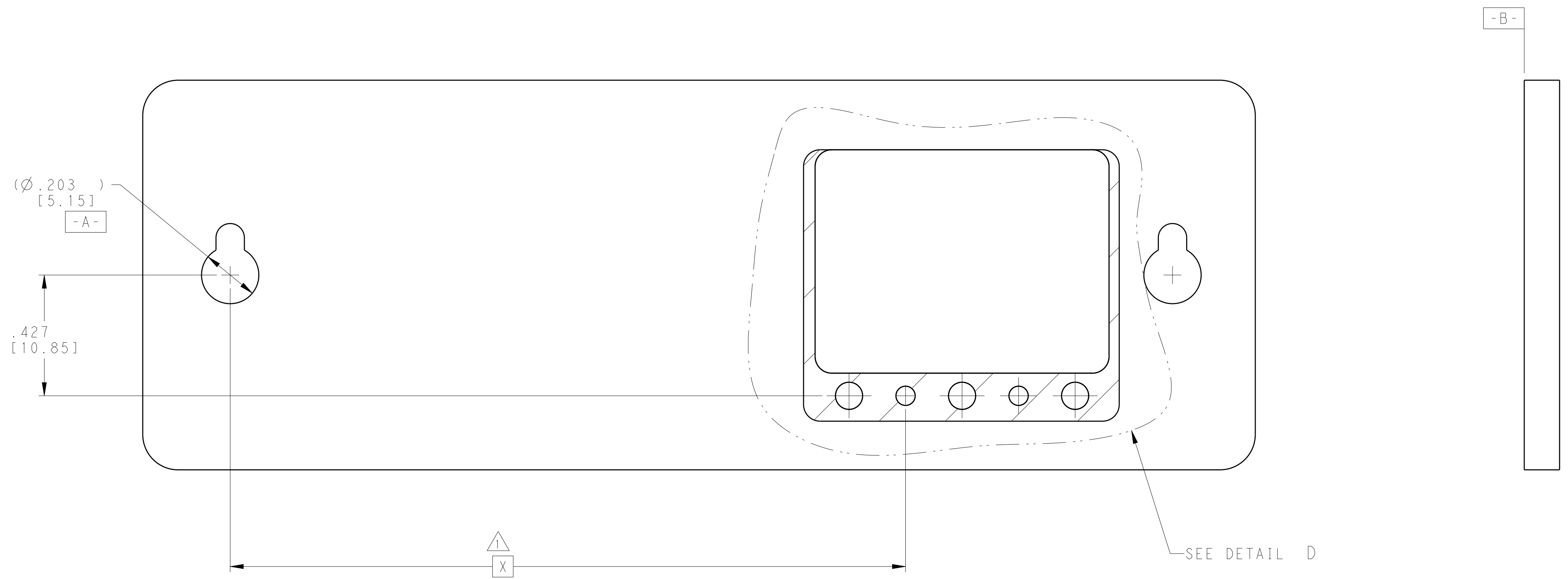

SEE VITA 67 SPECIFICATIONS FOR CONNECTOR LOCATION ON BACKPLANE PCB.

THIS DRAWING IS A CONTROLLED DOCUMENT.		DWN: L.SIPE 13AUG2018	TE Connectivity
DIMENSIONS: INCHES/mm		CHK: F.BLASICK 13AUG2018	
TOLERANCES UNLESS OTHERWISE SPECIFIED:		APVD: F.BLASICK 13AUG2018	NAME: 16 POSITION NanoRF MODULE
0 PLC ±	1 PLC ±	PRODUCT SPEC: 108-163006	P.C.B. MOUNT BACKPLANE
2 PLC ±	3 PLC ±	APPLICATION SPEC: 408-163016	VITA 67.3C FOOTPRINT COMPATIBLE
4 PLC ±	ANGLES ±	SIZE: A1	CAGE CODE: 00779
MATERIAL:	FINISH:	WEIGHT:	DRAWING NO: C=2341106
CUSTOMER DRAWING		SCALE: 8:1	SHEET 2 OF 2