

## DS75154 Quad Line Receiver

### General Description

The DS75154 is a quad monolithic line receiver designed to satisfy the requirements of the standard interface between data terminal equipment and data communication equipment as defined by EIA Standard RS-232C. Other applications are in relatively short, single-line, point-to-point data transmission systems and for level translators. Operation is normally from a single 5V supply; however, a built-in option allows operation from a 12V supply without the use of additional components. The output is compatible with most TTL and LS circuits when either supply voltage is used.

In normal operation, the threshold-control terminals are connected to the  $V_{CC1}$  terminal, pin 15, even if power is being supplied via the alternate  $V_{CC2}$  terminal, pin 16. This provides a wide hysteresis loop which is the difference between the positive-going and negative-going threshold voltages. In this mode, if the input voltage goes to zero, the output voltage will remain at the low or high level as determined by the previous input.

For fail-safe operation, the threshold-control terminals are open. This reduces the hysteresis loop by causing the

negative-going threshold voltage to be above zero. The positive-going threshold voltage remains above zero as it is unaffected by the disposition of the threshold terminals. In the fail-safe mode, if the input voltage goes to zero or an open-circuit condition, the output will go to the high level regardless of the previous input condition.

### Features

- Input resistance, 3 k $\Omega$  to 7 k $\Omega$  over full RS-232C voltage range
- Input threshold adjustable to meet "fail-safe" requirements without using external components
- Inverting output compatible with TTL or LS
- Built-in hysteresis for increased noise immunity
- Output with active pull-up for symmetrical switching speeds
- Standard supply voltage — 5V or 12V

### Schematic Diagram

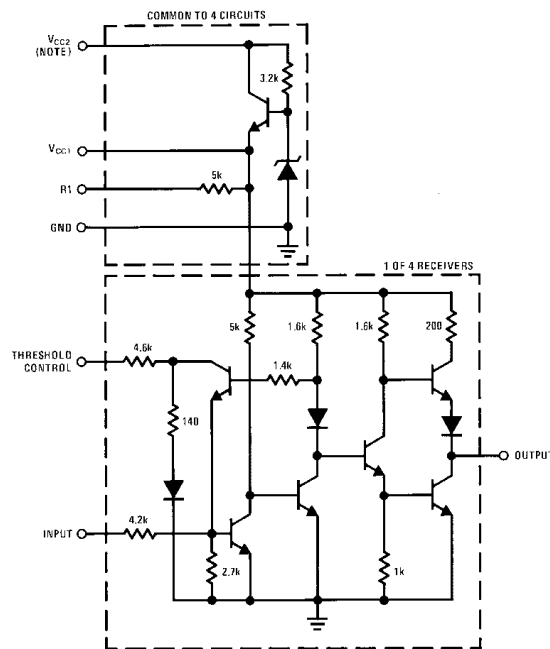

DS005795-1

**Note:** When using  $V_{CC1}$  (pin 15),  $V_{CC2}$  (pin 16) may be left open or shorted to  $V_{CC1}$ . When using  $V_{CC2}$ ,  $V_{CC1}$  must be left open or connected to the threshold control pins.

## Absolute Maximum Ratings (Note 2)

If Military/Aerospace specified devices are required, please contact the National Semiconductor Sales Office/Distributors for availability and specifications.

Normal Supply Voltage (Pin 15), ( $V_{CC1}$ )	7V
Alternate Supply Voltage (Pin 16), ( $V_{CC2}$ )	14V
Input Voltage	$\pm 25V$
Storage Temperature Range	$-65^{\circ}C$ to $+150^{\circ}C$
Maximum Power Dissipation (Note 1) at $25^{\circ}C$	
SO Package	650 mW
Lead Temperature (Soldering, 4 seconds)	$260^{\circ}C$

## Operating Conditions

	Min	Max	Units
Supply Voltage (Pin 15), ( $V_{CC1}$ )	4.5	5.5	V
Alternate Supply Voltage (Pin 16), ( $V_{CC2}$ )	10.8	13.2	V
Input Voltage		$\pm 15$	V
Temperature, ( $T_A$ )	0	$+70$	$^{\circ}C$

**Note 1:** Derate molded DIP package 10.9 mW/ $^{\circ}C$  above  $25^{\circ}C$ ; derate SO package 8.01 mW/ $^{\circ}C$  above  $25^{\circ}C$ .

## Electrical Characteristics (Notes 3, 4, 5)

Symbol	Parameter	Conditions	Min	Typ	Max	Units	
$V_{IH}$	High-Level Input Voltage	(Figure 1)	3			V	
$V_{IL}$	Low-Level Input Voltage	(Figure 1)			-3	V	
$V_{T+}$	Positive-Going Threshold Voltage	(Figure 1)	Normal Operation	0.8	2.2	3	V
			Fail-Safe Operation	0.8	2.2	3	V
$V_{T-}$	Negative-Going Threshold Voltage	(Figure 1)	Normal Operation	-3	-1.1	0	V
			Fail-Safe Operation	0.8	1.4	3	V
$V_{T+}-V_{T-}$	Hysteresis	(Figure 1)	Normal Operation	0.8	3.3	6	V
			Fail-Safe Operation	0	0.8	2.2	V
$V_{OH}$	High-Level Output Voltage	$I_{OH}=-400 \mu A$ , (Figure 1)	2.4	3.5		V	
$V_{OL}$	Low-Level Output Voltage	$I_{OL}=16 \text{ mA}$ , (Figure 1)		0.23	0.4	V	
$r_i$	Input Resistance	(Figure 2)	$\Delta V_i=-25V$ to $-14V$	3	5	7	k $\Omega$
			$\Delta V_i=-14V$ to $-3V$	3	5	7	k $\Omega$
			$\Delta V_i=-3V$ to $+3V$	3	6		k $\Omega$
			$\Delta V_i=3V$ to $14V$	3	5	7	k $\Omega$
			$\Delta V_i=14V$ to $25V$	3	5	7	k $\Omega$
$V_{I(OPEN)}$	Open-Circuit Input Voltage	$I_i=0$ , (Figure 3)	0	0.2	2	V	
$I_{OS}$	Short-Circuit Output Current (Note 6)	$V_{CC1}=5.5V$ , $V_i=-5V$ , (Figure 4)	-10	-20	-40	mA	
$I_{CC1}$	Supply Current From $V_{CC1}$	$V_{CC1}=5.5V$ , $T_A=25^{\circ}C$ , (Figure 5)		20	35	mA	
$I_{CC2}$	Supply Current From $V_{CC2}$	$V_{CC2}=13.2V$ , $T_A=25^{\circ}C$ , (Figure 5)		23	40	mA	

## Switching Characteristics

( $V_{CC1}=5V$ ,  $T_A=25^{\circ}C$ )

Symbol	Parameter	Conditions	Min	Typ	Max	Units
$t_{PLH}$	Propagation Delay Time, Low-to-High Level Output	$C_L=50 \text{ pF}$ , $R_L=390\Omega$ , (Figure 6)		22		ns
$t_{PHL}$	Propagation Delay Time, High-to-Low Level Output	$C_L=50 \text{ pF}$ , $R_L=390\Omega$ , (Figure 6)		20		ns
$t_{TLH}$	Transition Time, Low-to-High Level Output	$C_L=50 \text{ pF}$ , $R_L=390\Omega$ , (Figure 6)		9		ns
$t_{THL}$	Transition Time, High-to-Low Level Output	$C_L=50 \text{ pF}$ , $R_L=390\Omega$ , (Figure 6)		6		ns

**Note 2:** "Absolute Maximum Ratings" are those values beyond which the safety of the device cannot be guaranteed. Except for "Operating Temperature Range" they are not meant to imply that the devices should be operated at these limits. The table of "Electrical Characteristics" provides conditions for actual device operation.

**Note 3:** Unless otherwise specified min/max limits apply across the  $0^{\circ}C$  to  $+70^{\circ}C$  range for the DS75154. All typical values are for  $T_A=25^{\circ}C$  and  $V_{CC1}=5V$ .

**Note 4:** All currents into device pins shown as positive, out of device pins as negative, all voltages referenced to ground unless otherwise noted. All values shown as max or min on absolute value basis.

## Switching Characteristics (Continued)

**Note 5:** The algebraic convention where the most-positive (least-negative) limit is designated as maximum is used in this data sheet for logic and threshold levels only, e.g., when  $-3V$  is the maximum, the minimum limit is a more-negative voltage.

**Note 6:** Only one output at a time should be shorted.

## Typical Performance Characteristics

### Output Voltage vs Input Voltage

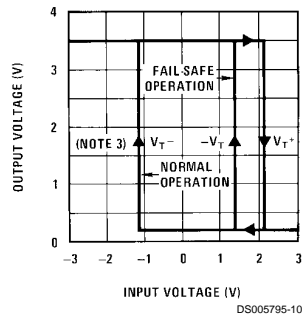

## Connection Diagram

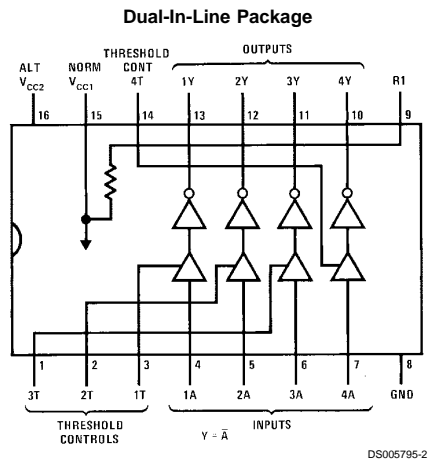

**Top View**  
**Order Number DS75154M**  
**See NS Package Number M16A**

## DC Test Circuits and Truth Tables

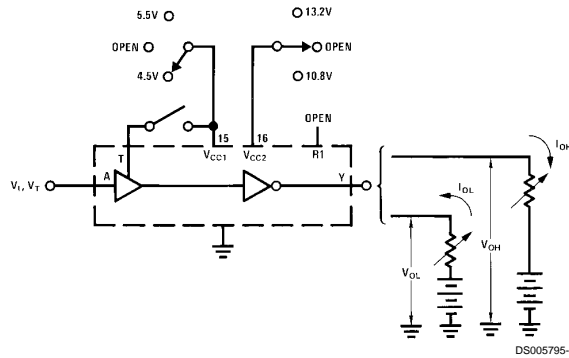

Test	Measure	A	T	Y	V <sub>CC1</sub> (Pin 15)	V <sub>CC2</sub> (Pin 16)
Open-Circuit Input (Fail-Safe)	V <sub>OH</sub>	Open	Open	I <sub>OH</sub>	4.5V	Open
	V <sub>OH</sub>	Open	Open	I <sub>OH</sub>	Open	10.8V
V <sub>T+</sub> min, V <sub>T-</sub> (Fail-Safe)	V <sub>OH</sub>	0.8V	Open	I <sub>OH</sub>	5.5V	Open
	V <sub>OH</sub>	0.8V	Open	I <sub>OH</sub>	Open	13.2V
V <sub>T+</sub> min (Normal)	V <sub>OH</sub>	(Note 7)	Pin 15	I <sub>OH</sub>	5.5V and T	Open
	V <sub>OH</sub>	(Note 7)	Pin 15	I <sub>OH</sub>	T	13.2V
V <sub>IL</sub> max, V <sub>T-</sub> min (Normal)	V <sub>OH</sub>	-3V	Pin 15	I <sub>OH</sub>	5.5V and T	Open
	V <sub>OH</sub>	-3V	Pin 15	I <sub>OH</sub>	T	13.2V
V <sub>IH</sub> min, V <sub>T+</sub> max, V <sub>T-</sub> max (Fail-Safe)	V <sub>OL</sub>	3V	Open	I <sub>OL</sub>	4.5V	Open
	V <sub>OL</sub>	3V	Open	I <sub>OL</sub>	Open	10.8V
V <sub>IH</sub> min, V <sub>T+</sub> max, (Normal)	V <sub>OL</sub>	3V	Pin 15	I <sub>OL</sub>	4.5V and T	Open
	V <sub>OL</sub>	3V	Pin 15	I <sub>OL</sub>	T	10.8V
V <sub>T-</sub> max (Normal)	V <sub>OL</sub>	(Note 8)	Pin 15	I <sub>OL</sub>	5.5V and T	Open
	V <sub>OL</sub>	(Note 8)	Pin 15	I <sub>OL</sub>	T	13.2V

**Note 7:** Momentarily apply -5V, then 0.8V.

**Note 8:** Momentarily apply 5V, then ground.

**FIGURE 1.** V<sub>IH</sub>, V<sub>IL</sub>, V<sub>T+</sub>, V<sub>T-</sub>, V<sub>OH</sub>, V<sub>OL</sub>

## DC Test Circuits and Truth Tables (Continued)

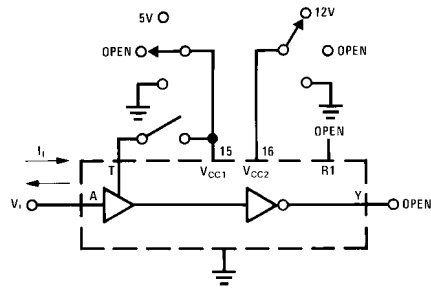

DS005795-4

$$r_1 = \frac{\Delta V_1}{\Delta I_1}$$

T	V <sub>CC1</sub> (Pin 15)	V <sub>CC2</sub> (Pin 16)
Open	5V	Open
Open	Gnd	Open
Open	Open	Open
Pin 15	T and 5V	Open
Gnd	Gnd	Open
Open	Open	12V
Open	Open	Gnd
Pin 15	T	12V
Pin 15	T	Gnd
Pin 15	T	Open

FIGURE 2.  $r_1$

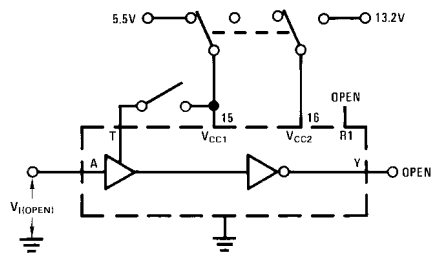

DS005795-5

T	V <sub>CC1</sub> (Pin 15)	V <sub>CC2</sub> (Pin 16)
Open	5.5V	Open
Pin 15	5.5V	Open
Open	Open	13.2V
Pin 15	T	13.2V

FIGURE 3.  $V_{I(OPEN)}$

## DC Test Circuits and Truth Tables

(Continued)

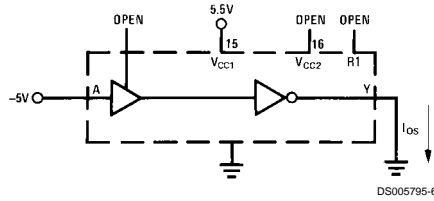

DS005795-6

Each output is tested separately.

FIGURE 4.  $I_{OS}$

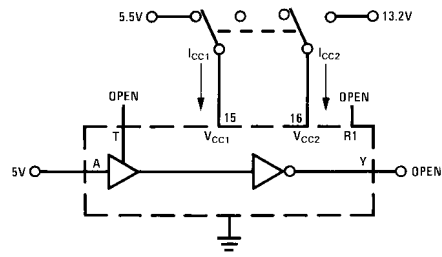

DS005795-7

All four line receivers are tested simultaneously.

FIGURE 5.  $I_{CC}$

## AC Test Circuit and Switching Time Waveforms

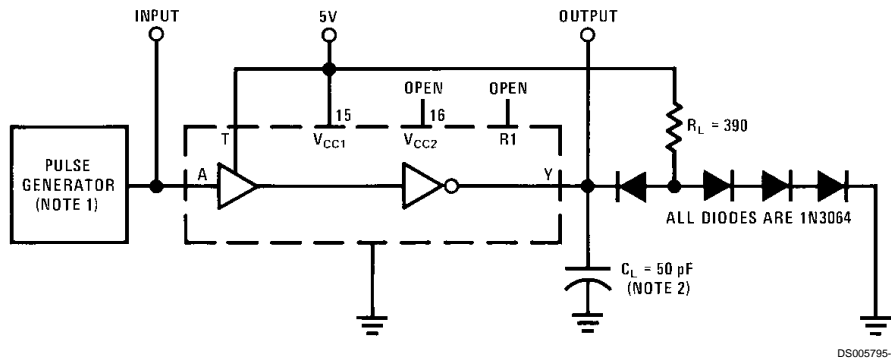

DS005795-8

**Note 1:** The pulse generator has the following characteristics:  $Z_{OUT} = 50\Omega$ ,  $t_W = 200$  ns, duty cycle  $\leq 20\%$ .

**Note 2:**  $C_L$  includes probe and jig capacitance.

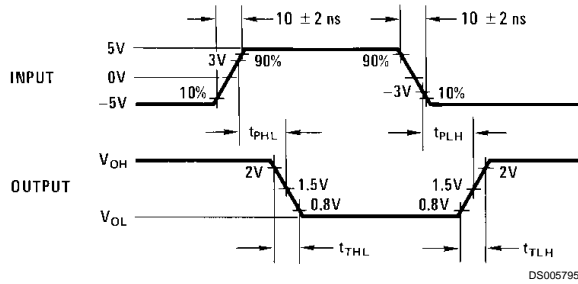

DS005795-9

FIGURE 6.



**Physical Dimensions** inches (millimeters) unless otherwise noted

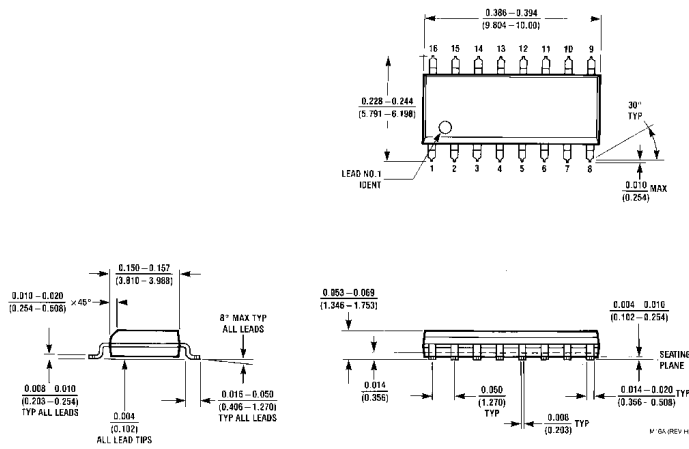

**SO Package (M)**  
**Order Number DS75154M**  
**NS Package Number M16A**

**LIFE SUPPORT POLICY**

NATIONAL'S PRODUCTS ARE NOT AUTHORIZED FOR USE AS CRITICAL COMPONENTS IN LIFE SUPPORT DEVICES OR SYSTEMS WITHOUT THE EXPRESS WRITTEN APPROVAL OF THE PRESIDENT OF NATIONAL SEMICONDUCTOR CORPORATION. As used herein:

- Life support devices or systems are devices or systems which, (a) are intended for surgical implant into the body, or (b) support or sustain life, and whose failure to perform when properly used in accordance with instructions for use provided in the labeling, can be reasonably expected to result in a significant injury to the user.
- A critical component in any component of a life support device or system whose failure to perform can be reasonably expected to cause the failure of the life support device or system, or to affect its safety or effectiveness.

	<b>National Semiconductor Corporation</b> Americas Tel: 1-800-272-9959 Fax: 1-800-737-7018 Email: support@nsc.com	<b>National Semiconductor Europe</b> Fax: +49 (0) 1 80-530 85 86 Email: europe.support@nsc.com Deutsch Tel: +49 (0) 1 80-530 85 85 English Tel: +49 (0) 1 80-532 78 32 Français Tel: +49 (0) 1 80-532 93 58 Italiano Tel: +49 (0) 1 80-534 16 80	<b>National Semiconductor Asia Pacific Customer Response Group</b> Tel: 65-2544466 Fax: 65-2504466 Email: sea.support@nsc.com	<b>National Semiconductor Japan Ltd.</b> Tel: 81-3-5620-6175 Fax: 81-3-5620-6179
	www.national.com			

National does not assume any responsibility for use of any circuitry described, no circuit patent licenses are implied and National reserves the right at any time without notice to change said circuitry and specifications.