

DO NOT SCALE FROM THIS PRINT

IJ5-XX-05.0-X-X-X-**XR**

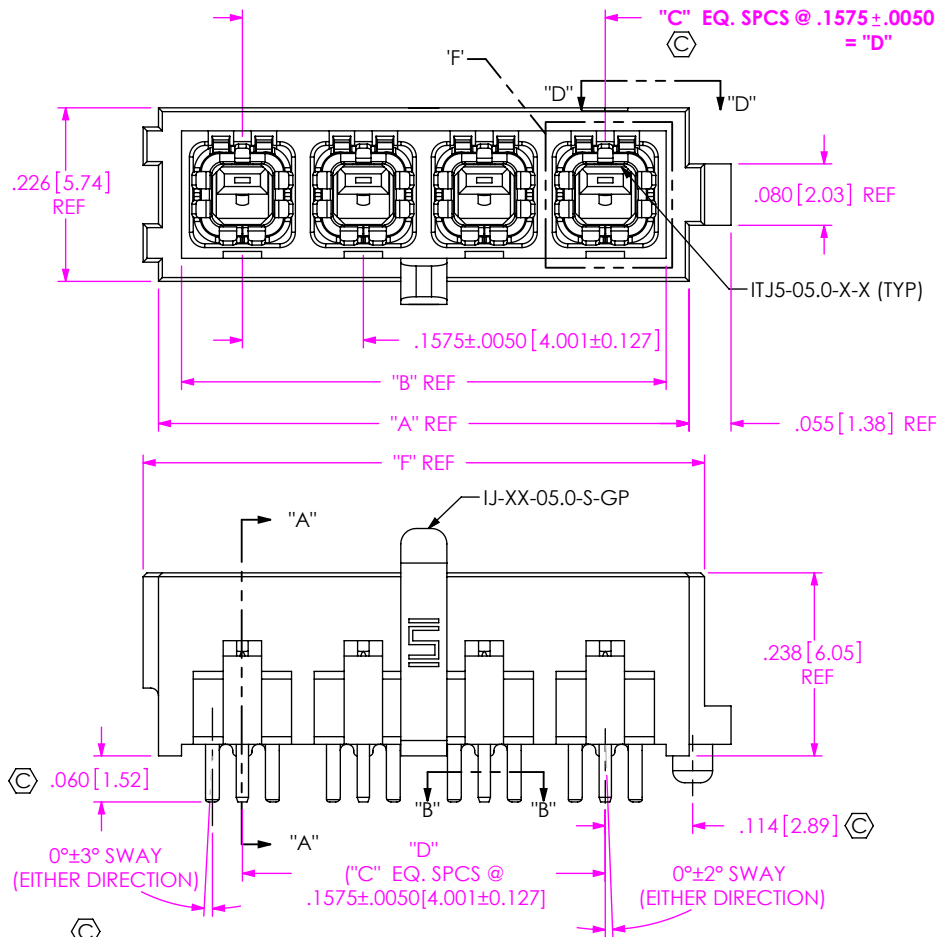

No. OF POSITIONS (PER ROW)
 -01: 1 POSITION (SEE NOTE 5)
 -02: 2 POSITIONS
 -04: 4 POSITIONS
 -06: 6 POSITIONS
 -08: 8 POSITIONS

PACKAGING (SEE NOTE 7 & 8)
 -TR: TAPE & REEL
 -FR: FULL REEL QTY TAPE & REEL

LEAD STYLE
 -05.0: SEE TABLES 1, 4 & 5

TAIL OPTIONS
 -1: .062" THICK BOARD

PLATING OPTIONS
 -L: 10µ" SELECTIVE GOLD IN CONTACT AREA, MATTE TIN ON TAIL

ROW
 -S: SINGLE ROW
 -D: DOUBLE ROW (SEE NOTE 5)

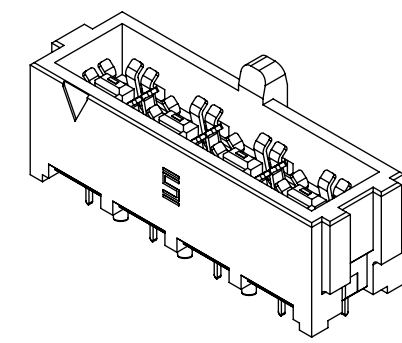
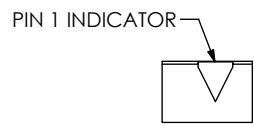

FIG 1 (IJ5-04-05.0-L-S-1-XR SHOWN)

IJ5 ASSEMBLY P/N	IJ-XX-05.0-X-XX P/N	ITJ5-X-05.0-X-X P/N
IJ5-XX-05.0-X-X-X	IJ-XX-05.0-X-GP	ITJ5-X-05.0-X-X

No. OF POS PER ROW	"A" REF	"B" REF	"C"	"D" ± .005	"F"
-01	.219 [5.55]	.158 [4.00]	N/A	N/A N/A	.2590 [6.579]
-02	.376 [9.55]	.315 [8.00]	1	.1575 [4.001]	.4160 [10.566]
-04	.691 [17.55]	.630 [16.00]	3	.4725 [12.002]	.7310 [18.567]
-06	1.006 [25.55]	.945 [24.00]	5	.7875 [20.003]	1.0460 [26.568]
-08	1.321 [33.55]	1.260 [32.00]	7	1.1025 [28.004]	1.3610 [34.569]



PARTIAL VIEW "D"-"D" SCALE 3 : 1

IP5 LEAD STYLE	STACKHEIGHT
IP5-XX-05.0-X-X-X	10.0MM [0.394]

NOTES:

1. Ⓢ REPRESENTS A CRITICAL DIMENSION.
2. MINIMUM PUSH OUT FORCE .5 LBS. [0.23 Kg.]
3. NOTE DELETED
4. GUIDE POST NOT AVAILABLE WHEN USED TO MAKE A ASSEMBLED 7MM STACK HEIGHT ASSEMBLY. (SEE SHEET 2, FIG. 3)
5. -1 POSITION NOT AVAILABLE WITH -D ROW OPTION.
6. TAPE & REEL IS STANDARD PACKAGING
7. ORDERS WILL BE PACKAGED ACCORDING TO THE SAMTEC PACKAGING EFFICIENCY STANDARDS (SPES) FOUND ON WWW.SAMTEC.COM
8. ATTACH LABEL -4X2 TO EACH REEL

UNLESS OTHERWISE SPECIFIED, DIMENSIONS ARE IN INCHES.
 TOLERANCES ARE:
 DECIMALS ANGLES
 .XX: ±.01 [0.3] 2°
 .XXX: ±.005 [0.13]
 .XXXX: ±.0030 [0.076]

PROPRIETARY NOTE
 THIS DOCUMENT CONTAINS CONFIDENTIAL AND PROPRIETARY INFORMATION AND ALL DESIGN, MANUFACTURING, REPRODUCTION, USE, PATENT RIGHTS AND SALES RIGHTS ARE EXPRESSLY RESERVED BY SAMTEC, INC. THIS DOCUMENT SHALL NOT BE DISCLOSED, IN WHOLE OR PART, TO ANY UNAUTHORIZED PERSON OR ENTITY NOR REPRODUCED, TRANSFERRED OR INCORPORATED IN ANY OTHER PROJECT IN ANY MANNER WITHOUT THE EXPRESS WRITTEN CONSENT OF SAMTEC, INC.

MATERIAL: DO NOT SCALE DRAWING SHEET SCALE: 4:1
 BODY: HIGH TEMP NYLON, COLOR: BLACK
 SHIELD: COPPER ALLOY
 CONTACT: COPPER ALLOY
 DIELECTRIC: LCP, COLOR: BLACK

F:\DWG\MISC\MKTG\IJ5-XX-05.0-X-X-XR-MKT.SLDDRW

520 PARK EAST BLVD, NEW ALBANY, IN 47150
 PHONE: 812-944-6733 FAX: 812-948-5047
 e-Mail: info@SAMTEC.com code: 55322

DESCRIPTION:
 CONTACT ARRAY ASSEMBLY, IJ5 CONNECTOR

DWG. NO.
IJ5-XX-05.0-X-X-X-XR****

BY: PIERCE 11/20/2007 SHEET 1 OF 2

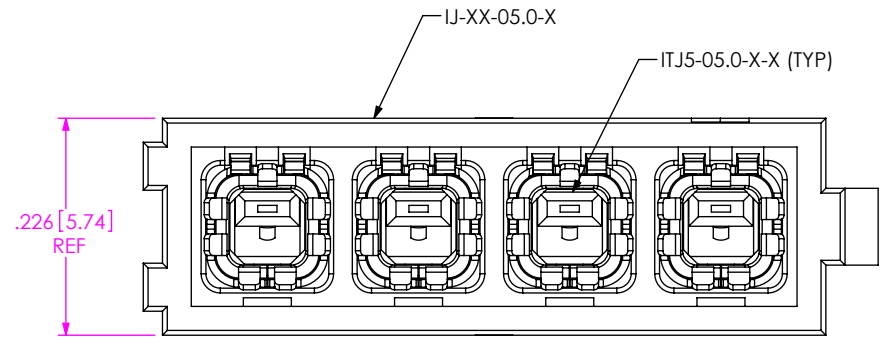
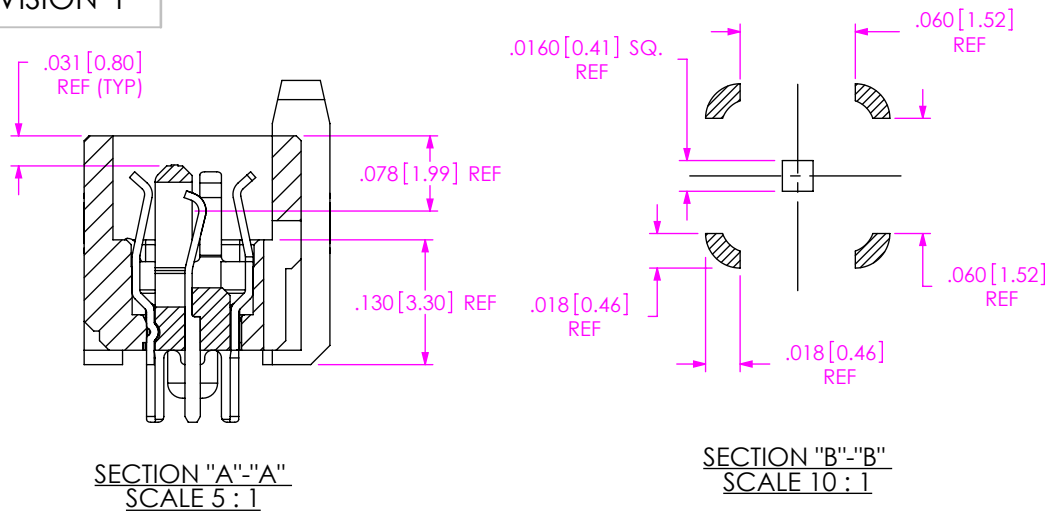
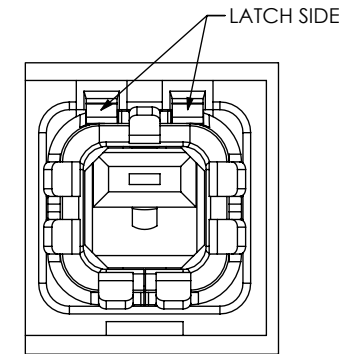
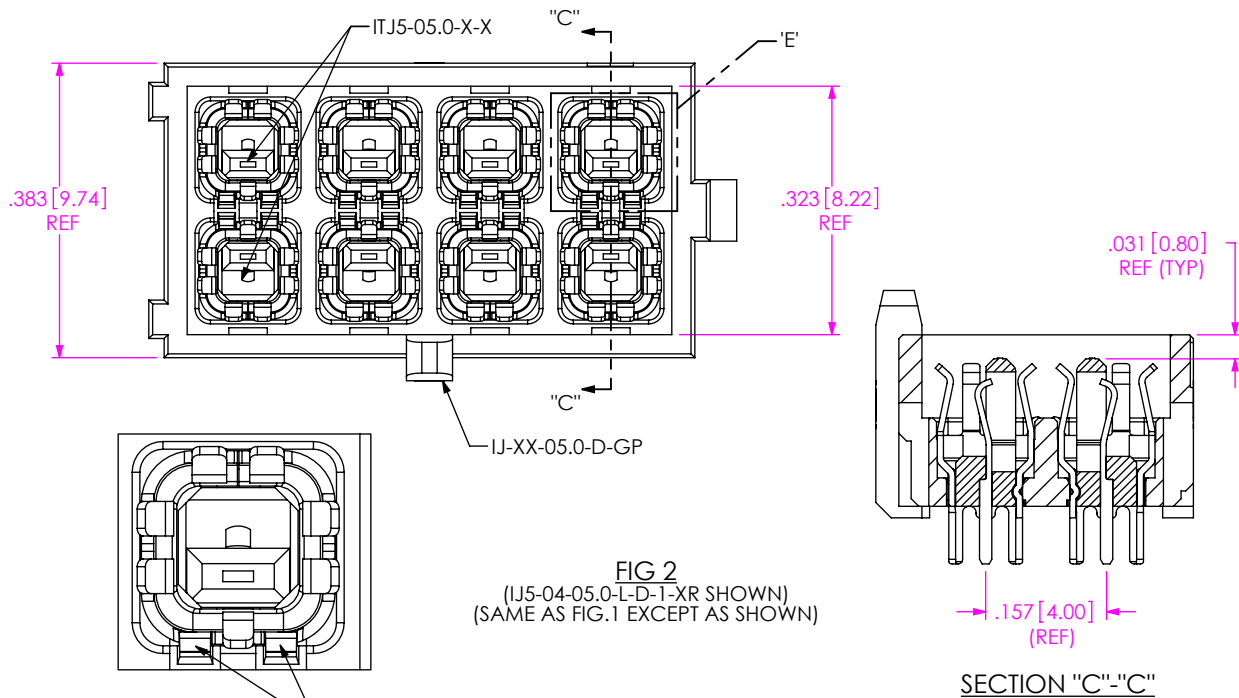
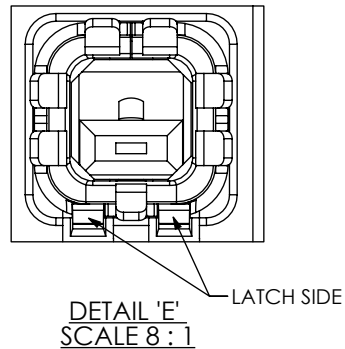

FIG 3
(IJ5-04-05.0-X-S-X SHOWN)
(NO GUIDE POST - SEE NOTE 4)
(SAME AS FIG 1 EXCEPT AS SHOWN)



DETAIL 'F'
SCALE 8 : 1



PROPRIETARY NOTE
THIS DOCUMENT CONTAINS CONFIDENTIAL AND PROPRIETARY INFORMATION AND ALL DESIGN, MANUFACTURING, REPRODUCTION, USE, PATENT RIGHTS AND SALES RIGHTS ARE EXPRESSLY RESERVED BY SAMTEC, INC. THIS DOCUMENT SHALL NOT BE DISCLOSED, IN WHOLE OR PART, TO ANY UNAUTHORIZED PERSON OR ENTITY NOR REPRODUCED, TRANSFERRED OR INCORPORATED IN ANY OTHER PROJECT IN ANY MANNER WITHOUT THE EXPRESS WRITTEN CONSENT OF SAMTEC, INC.

DO NOT SCALE DRAWING

SHEET SCALE: 4:1

samtec

520 PARK EAST BLVD, NEW ALBANY, IN 47150
PHONE: 812-944-6733 FAX: 812-948-5047
e-Mail: info@SAMTEC.com code: 55322

DESCRIPTION:
CONTACT ARRAY ASSEMBLY, IJ5 CONNECTOR

DWG. NO.
IJ5-XX-05.0-X-X-X-XR

BY: PIERCE 11/20/2007 SHEET 2 OF 2