

OD6038 XC Series with PWM and Tachometer

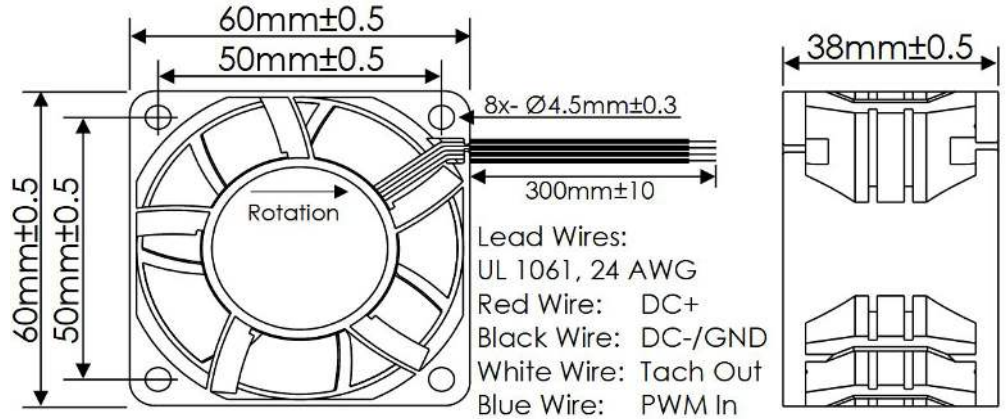

DC Fans with PWM and Tach - 12, 24V
60mm x 38mm
(2.36" x 1.50")



Frame	PBT, UL94 V-0 Plastic	Operating Temperature -10°C ~ +70°C Storage Temperature -40°C ~ +70°C Life Expectancy 70,000 Hours (L10 at 40°C) Installed Options PWM Speed Control Open Collector Tach Output Available Options IP Ratings Alarm Output 5V TTL Tach Output Weight: 0.28 lbs
Impeller	PBT, UL94 V-0 Plastic	
Connection	4x Wire Leads, 24 AWG	
Motor	Brushless DC, Auto Cutoff, Auto Restart, Electronically Protected, Polarity Protected	
Bearing System	Ball Bearings	
Dielectric Strength	500VDC/min, <1mA	
Insulation Resistance	≥10MΩ @ 500 VDC	

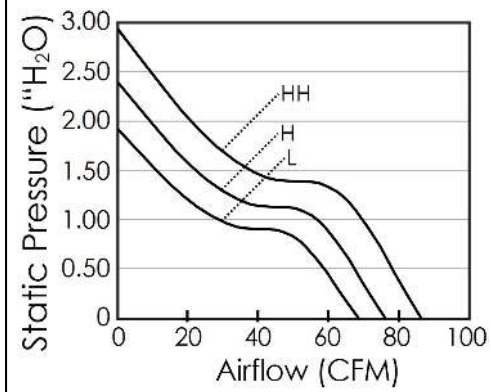

Part Number	Rated Voltage (Volts DC)	Voltage Range (Volts DC)	Input Power (Watts)	Rated Current (Amps)	Rated Speed (RPM)	Max Airflow (CFM)	Noise Level (dBA)	Max Static Pressure ("H ₂ O)
OD6038-12HHBXC10A	12	9 ~ 13.8	36.0	2.70	16000	86	66	2.95
OD6038-12HBXC10A	12	9 ~ 13.8	28.8	2.10	14500	76	64	2.40
OD6038-12LBXC10A	12	9 ~ 13.8	21.6	1.45	13000	68	61	1.95
OD6038-24HHBXC10A	24	16 ~ 26	30.0	1.25	16000	86	66	2.95

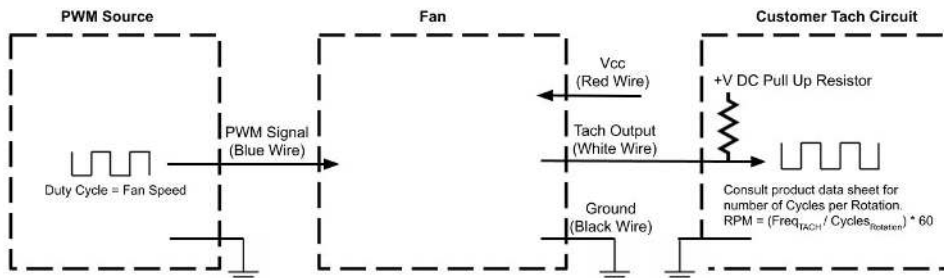

PWM Max High Voltage: 5V
 PWM Max Sink Current: 5mA
 PWM Frequency Range: 18KHz-30KHz
 PWM Typical Frequency: 25KHz
 PWM Minimum Startup Duty Cycle: 0%
 RPM at 0% Duty Cycle: 3200 RPM±10%
 RPM will be full speed if PWM input is disconnected.
 Tach Max Pullup Voltage: Vcc of fan
 Tach Max Sink Current: 5mA
 Tach Cycles per Rotation: 2

OD6038 XC Series with Tachometer



DC Fans with Tach - 12, 24V
60mm x 38mm
(2.36" x 1.50")

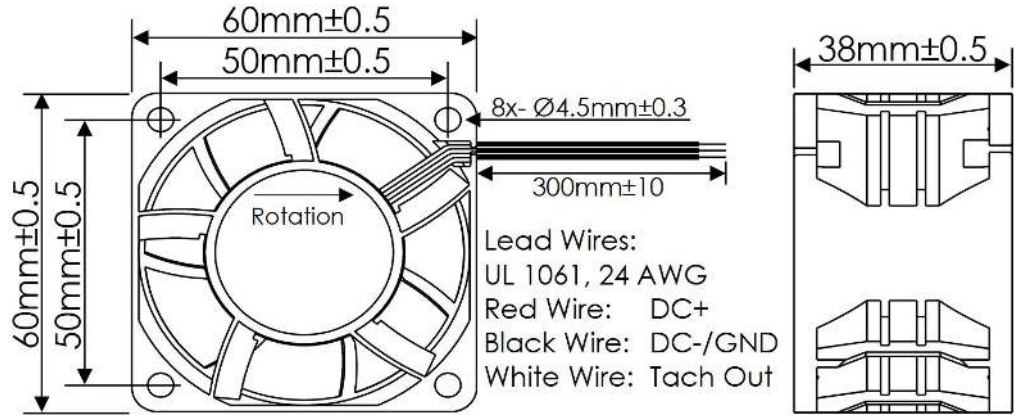

Frame	PBT, UL94 V-0 Plastic	Operating Temperature -10°C ~ +70°C Storage Temperature -40°C ~ +70°C Life Expectancy 70,000 Hours (L10 at 40°C) Installed Options Open Collector Tach Output Available Options 5V TTL Tach Output Weight: 0.28 lbs
Impeller	PBT, UL94 V-0 Plastic	
Connection	3x Wire Leads, 24 AWG	
Motor	Brushless DC, Auto Cutoff, Auto Restart, Electronically Protected, Polarity Protected	
Bearing System	Ball Bearings	
Dielectric Strength	500VDC/min, <1mA	
Insulation Resistance	≥10MΩ @ 500 VDC	

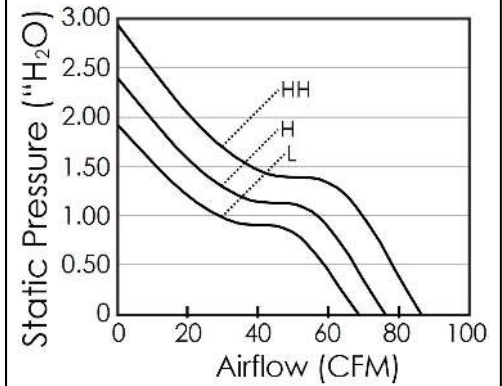

Part Number	Rated Voltage (Volts DC)	Voltage Range (Volts DC)	Input Power (Watts)	Rated Current (Amps)	Rated Speed (RPM)	Max Airflow (CFM)	Noise Level (dBA)	Max Static Pressure ("H ₂ O)
OD6038-12HHBXC01A	12	9 ~ 13.8	36.0	2.70	16000	86	66	2.95
OD6038-12HBXC01A	12	9 ~ 13.8	28.8	2.10	14500	76	64	2.40
OD6038-12LBXC01A	12	9 ~ 13.8	21.6	1.45	13000	68	61	1.95
OD6038-24HHBXC01A	24	16 ~ 26	30.0	1.25	16000	86	66	2.95

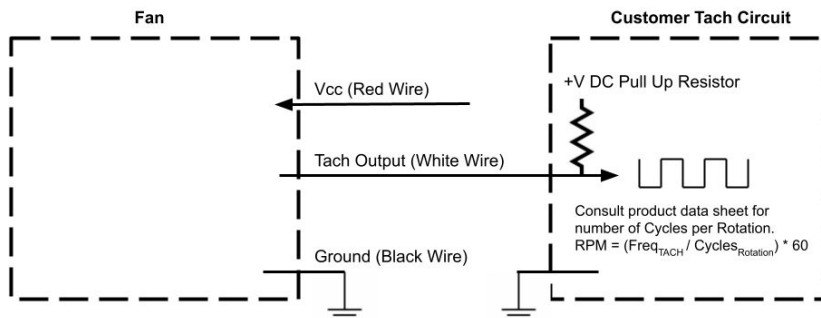

Tach Max Pullup Voltage:
Tach Max Sink Current:
Tach Cycles per Rotation:

Vcc of fan
5mA
2