

Data Sheet	AMM-2742-T-EB-R
------------	-----------------

PUI Audio is proud to release a line of premium, high-fidelity MEMS wide-band microphones that cover the entire audio band from 20 Hz up to 18 kHz —and up to 20 kHz on some models—while featuring industry-best consistency of ± 1 dB across the entire frequency response.

Quickly test and prototype the top-firing **AMM-2742-T-R** with this evaluation board. Solder pads with pre-punched through-holes make wiring to the evaluation board quick-and-easy!

Specifications

Parameters	Values	Units
Sensitivity (1 kHz @ 50cm) 0 dB=1V/Pa	-42 \pm 1	dB
Rated Voltage	2	VDC
Operating Voltage Range	1.5 to 3.6	VDC
Output Impedance (@ 1 kHz)	300	Ω
Current consumption (at 2 VDC/at 3.6 VDC)	80/150	μ A
Signal-to-Noise Ratio (1kHz, 94 dB input, A-weighted)	59	dB
Decreasing Voltage (0 dB=1V/Pa, 3.6 to 1.5 VDC)	0.5	dB
Frequency Range	20 – 20,000	Hz
Total Harmonic Distortion (94 dB @ 50cm, 1 kHz)	0.5%	-
Acoustic Overload Point (AOP) (50cm, 1kHz, 10% THD)	123	dB
Directivity	Omnidirectional	
Environmental Compliances	RoHS/Halogen Free	
Power Supply Rejection (PSR, 100 mVpp Square Wave @ 217 Hz, A-weighted)	-90	dB
Operating Temperature (VDD < 3 VDC)	-40 ~ +100	$^{\circ}$ C
Operating Temperature (VDD > 3 VDC)	-40 ~ +70	$^{\circ}$ C
Storage Temperature	-55 ~ +150	$^{\circ}$ C

Absolute Maximum Ratings

Parameters	Values	Units
Max Voltage on Any Pin	4	VDC
Max Sound Pressure Level	160	dB
Max Mechanical Shock	10,000	Gs
Max Vibration	Pre-MIL-STD-883 Method 2007, Test Condition B	

Measurement Method (with speaker spaced 50cm from microphone)

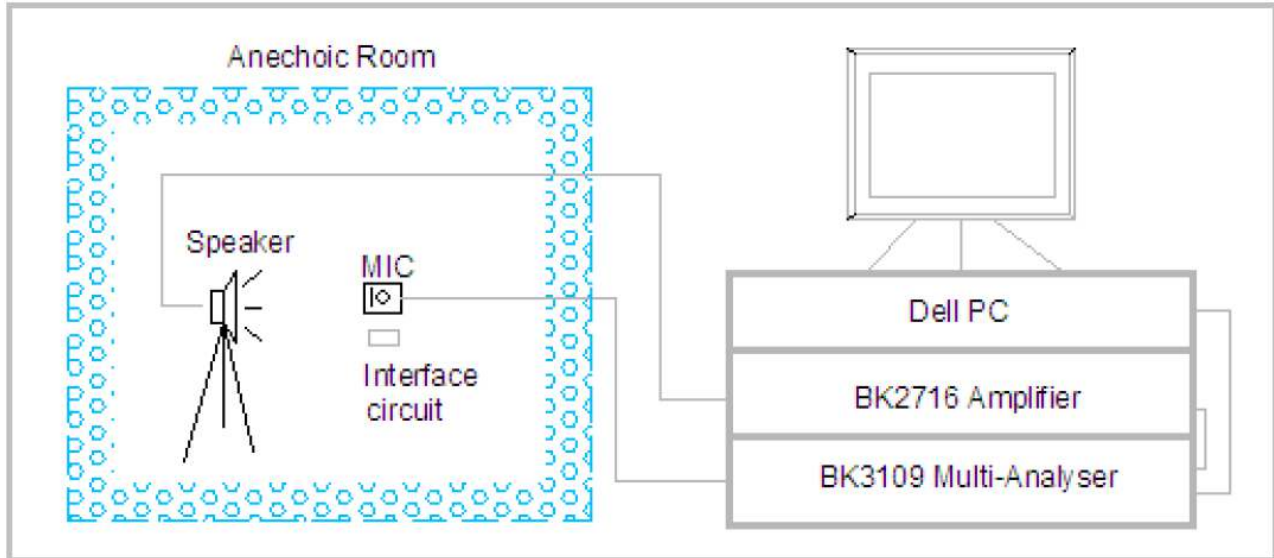

Recommended Drive Circuit (capacitor included on evaluation board)

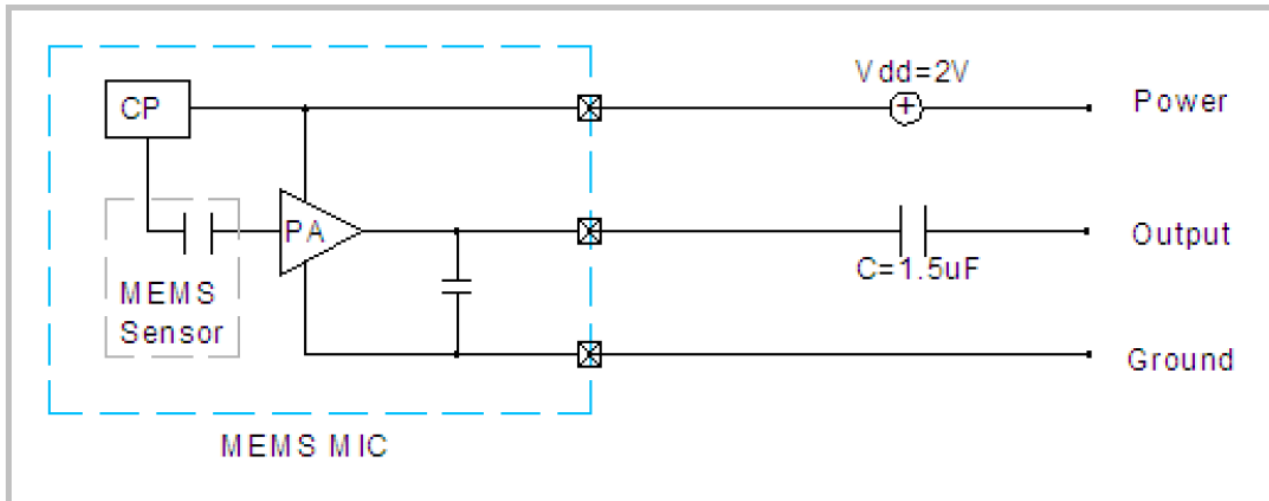

Typical Frequency Response

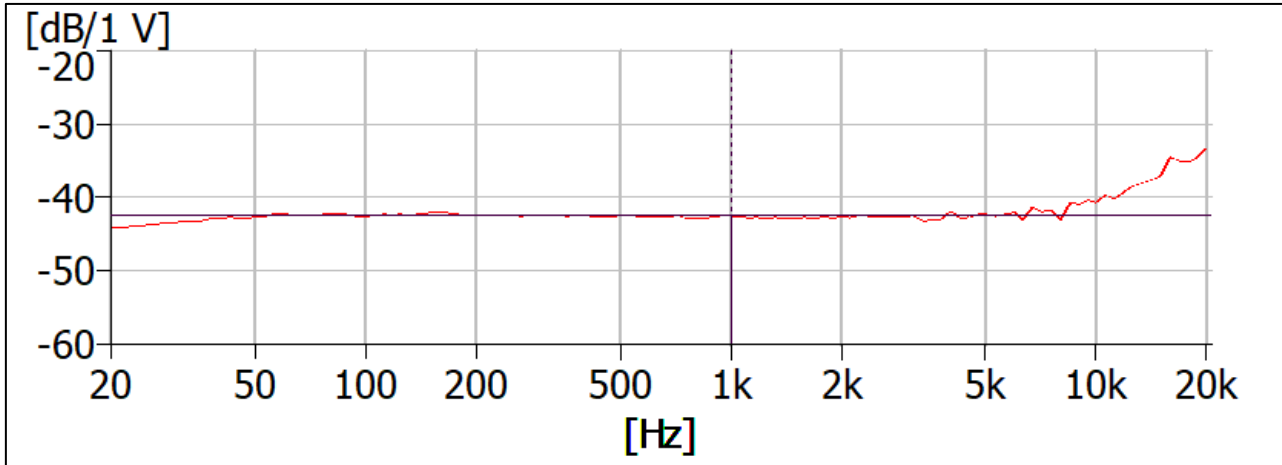

Frequency Response Mask (100% Pass/Fail Test for Microphones)

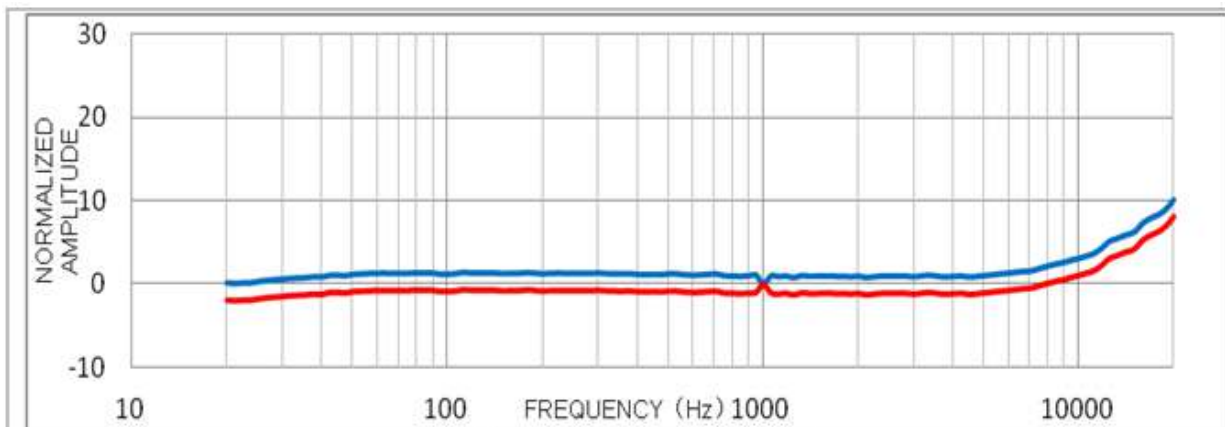

Frequency Response Mask

Frequency (Hz)	Upper	Limit
20	0	-2
50	1	-1
100	1	-1
900	1	-1
1000	0	0
1100	1	-1
2000	1	-1
5000	1	-1
10000	3	1
15000	6	4
20000	10	8

Free-field frequency response normalized to 1kHz sensitivity value.

Total Harmonic Distortion + Noise versus SPL Input (with acoustic source at 50cm)

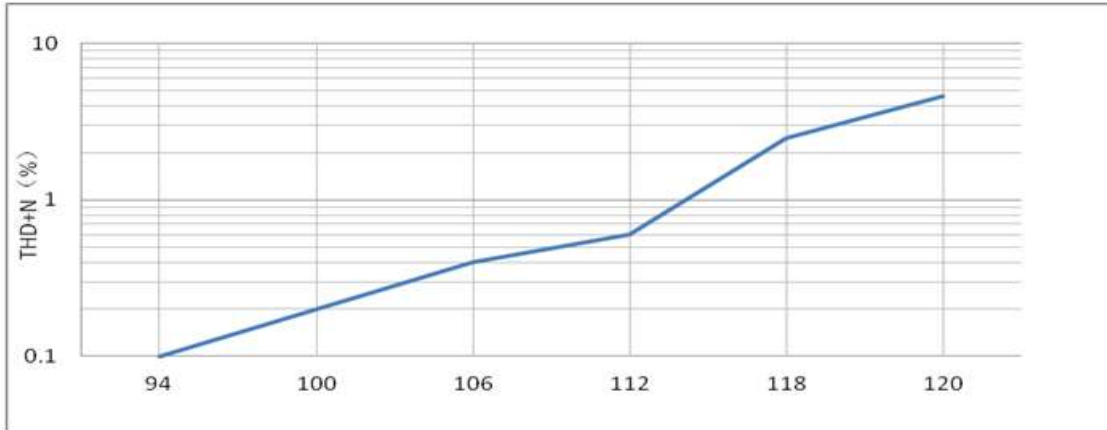

Microphone Output versus SPL Input (with acoustic source at 50cm)

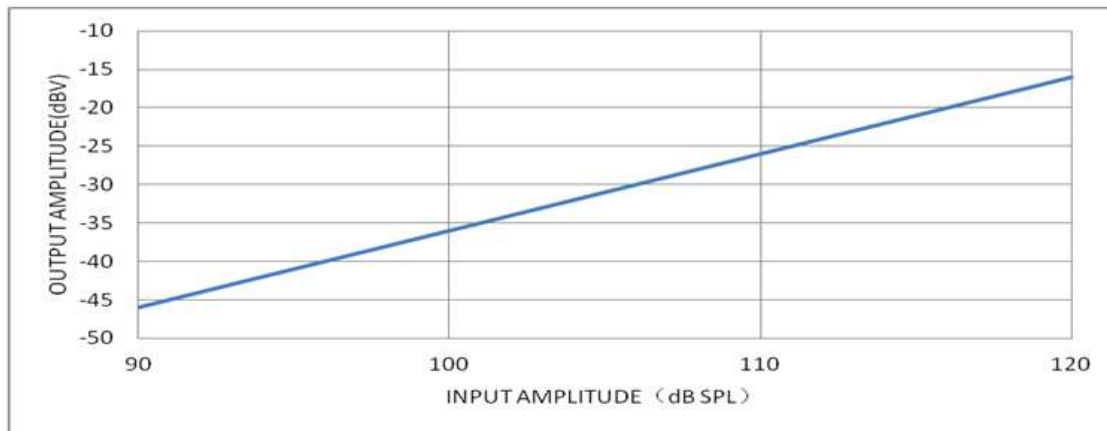

Ultrasonic Frequency Response (Sensitivity normalized to 0 dB)

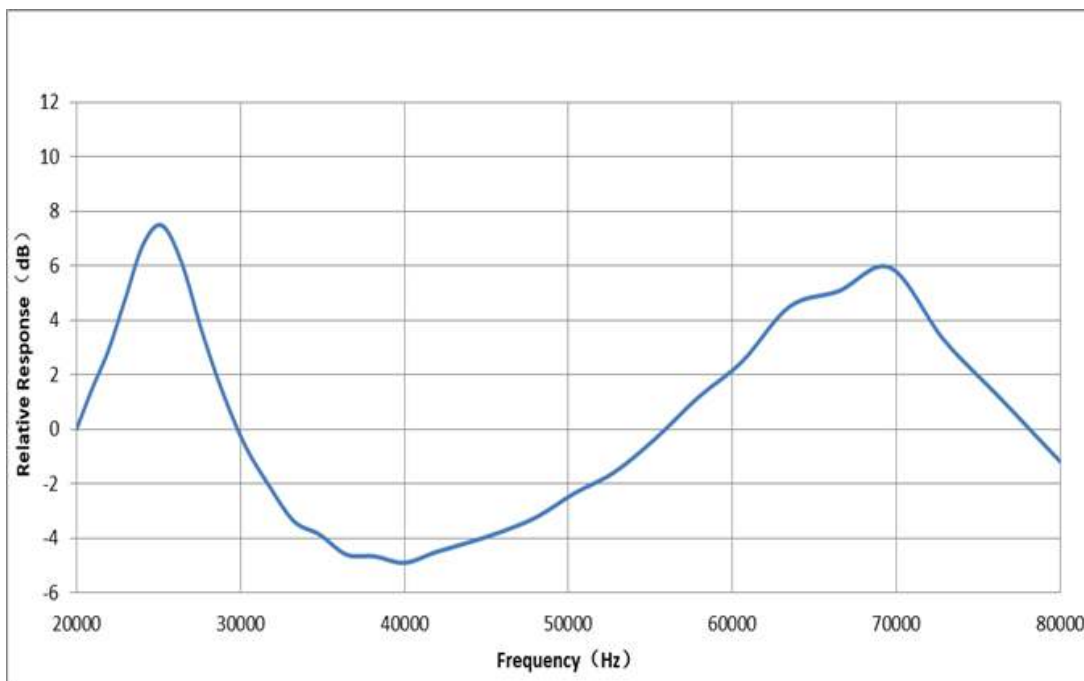

Reliability Testing

Type of Test	Test Specifications
Simulated Reflow (Without Solder)	Samples for qualification testing require 3 passes 260±5 °C reflow solder profiles. 2 hours of setting time is required between each reflow profile test.
Static Humidity	Precondition at +25°C for 1 hour. Expose to +85°C with 85% relative humidity for 1000 hours. Finally, dry at room ambient for 3±1 hour before taking final measurement.
Temperature Shock	Each cycle shall consist of 30 minutes at -40°C, 30 minutes at +125°C with 5 minutes transition time. Test duration is for 30 cycles, starting from cold to hot temperature.
ESD Sensitivity	Perform ESD sensitivity threshold measurements for each contact according to MIL-STD-883G, Method 3015.7 for Human Body Model. Identify the ESD threshold levels indicating passage of 8000V Human Body Model.
Vibration Test	Vibrate randomly along three perpendicular directions for 30 minutes in each direction, 4 cycles from 20~2000 Hz with a peak acceleration of 20 Gs.
Shock Test	Subject samples to half-sine shock pulses (3000±15% Gs for 0.3ms) in each direction, for a total of 18 shocks.
Drop Test	Drop samples from 1.5m height onto a steel surface, total 18 times and inspected for mechanical damage.
Operation Life	Subject samples to +125°C for 168 hours under full maximum rated voltage.

Microphone frequency response and sensitivity shall not deviate more than ±3 dB.

Dimensions

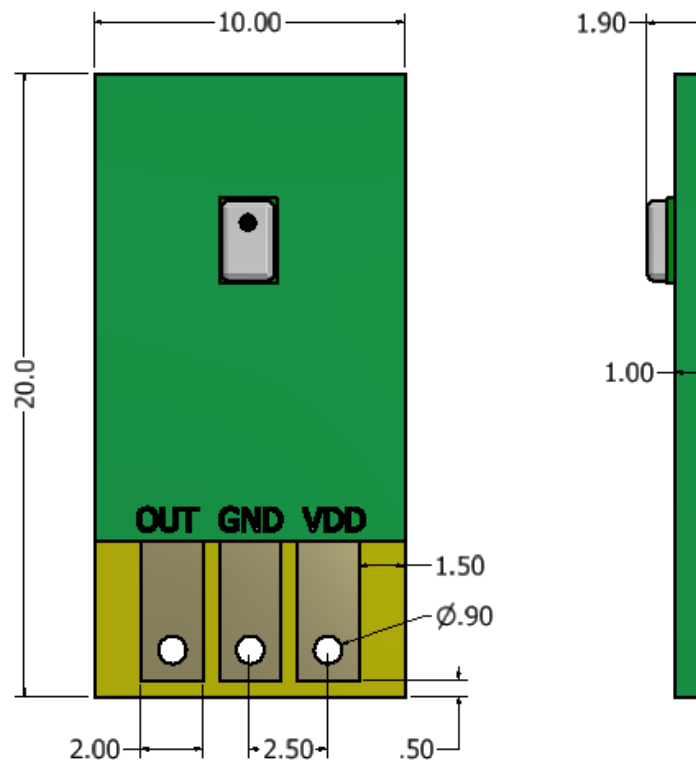

Specifications Revisions

Revision	Description	Date
-	Released from Engineering	1/31/2020
A	Added Ultrasonic Response	5/19/2020

Note:

1. Unless otherwise specified:
 - A. All dimensions are in millimeters.
 - B. Default tolerances are $\pm 0.5\text{mm}$ and angles are $\pm 3^\circ$.
2. Specifications subject to change or withdrawal without notice.