

THIS DRAWING IS UNPUBLISHED. RELEASED FOR PUBLICATION
 © COPYRIGHT BY TYCO ELECTRONICS CORPORATION. ALL INTERNATIONAL RIGHTS RESERVED.

LOC	DIST	REVISIONS			
P	LTR	DESCRIPTION	DATE	DWN	APVD
	F	REVISED PER ECO-09-010589	5/1/09	SS	MS

- 1. MATERIAL: .0157 THK BRASS.
- 2. COPPER FLASH .000100 MIN OVER BRASS PART.
- 3. TIN PLATING .000080 MIN THK

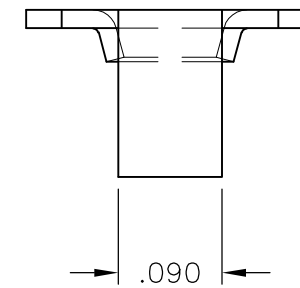
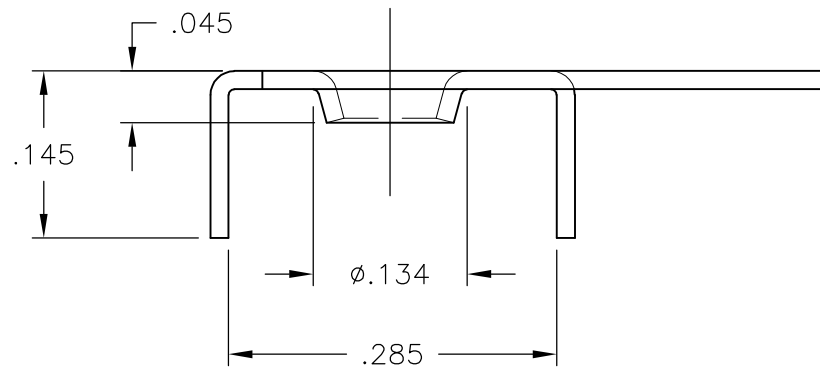
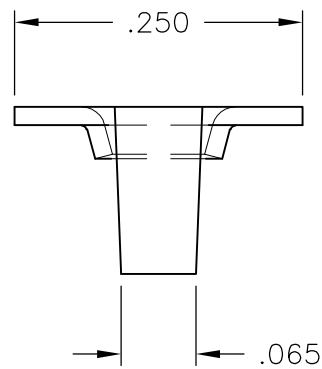
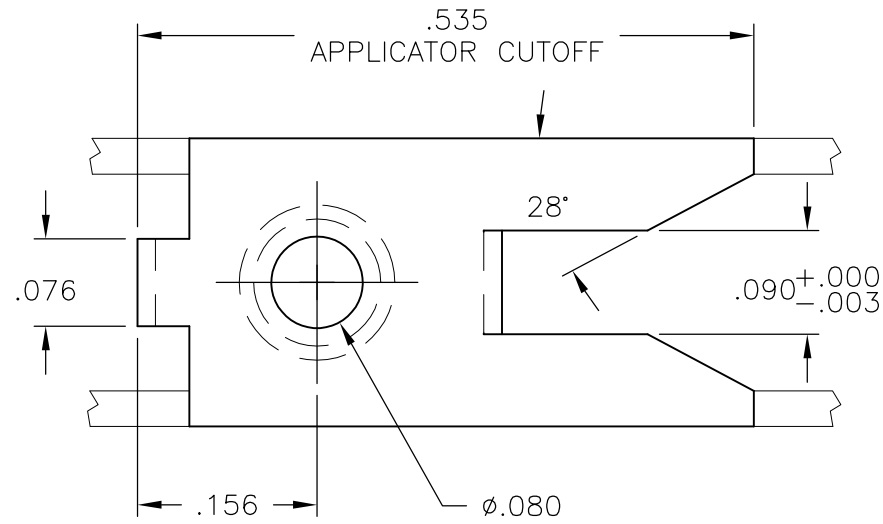

61480-2

PART NUMBER

THIS DRAWING IS A CONTROLLED DOCUMENT.		DWN S SCHLEGEL 09APR2009	Tyco Electronics Corporation Harrisburg, PA 17105-3608		
DIMENSIONS: INCHES	TOLERANCES UNLESS OTHERWISE SPECIFIED:	CHK M STRECKEWALD 4/9/09	NAME PHASING LINE CLIP		
	0 PLC ± -	APVD M STRECKEWALD 4/9/09	PRODUCT SPEC		
	1 PLC ± -	PRODUCT SPEC	-		
	2 PLC ± .02	APPLICATION SPEC	-		
	3 PLC ± .010	WEIGHT	-		
	4 PLC ± -	CUSTOMER DRAWING	SIZE A3	CAGE CODE 00779	DRAWING NO C-61480
	ANGLES ± 2'	SCALE	6:1		SHEET
MATERIAL - 1	FINISH -	RESTRICTED TO		1 OF 2	
		REV		F	

THIS DRAWING IS UNPUBLISHED. RELEASED FOR PUBLICATION
 © COPYRIGHT BY TYCO ELECTRONICS CORPORATION. ALL INTERNATIONAL RIGHTS RESERVED.

LOC	DIST	REVISIONS			
P	LTR	DESCRIPTION	DATE	DWN	APVD
-	-	SEE SHEET 1	-	-	-

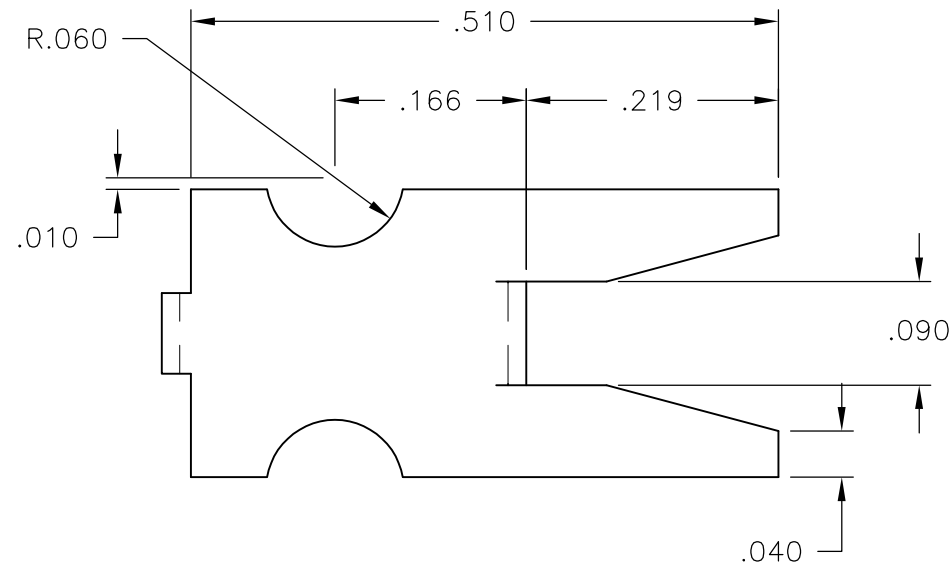

SUPERSEDED BY
1986550-1

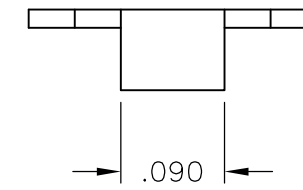
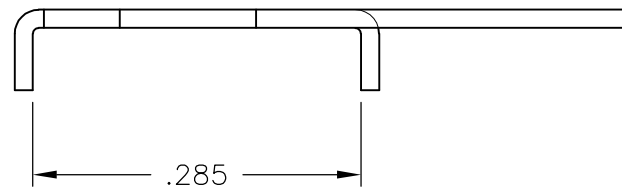
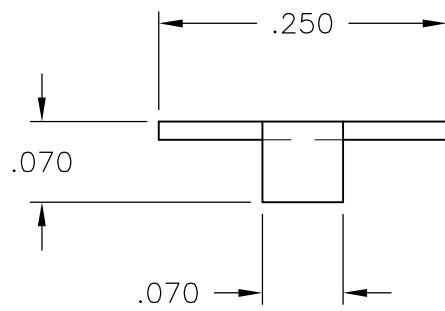

4 SUPERCEDED BY 1986550-1 61480-3
 PART NUMBER

THIS DRAWING IS A CONTROLLED DOCUMENT.		DWN S SCHLEGEL 09APR2009	Tyco Electronics Corporation Harrisburg, PA 17105-3608	
DIMENSIONS: INCHES		CHK M STRECKEWALD 4/9/09	NAME PHASING LINE CLIP	
TOLERANCES UNLESS OTHERWISE SPECIFIED:		APVD M STRECKEWALD 4/9/09	PRODUCT SPEC -	
0 PLC ± - 1 PLC ± - 2 PLC ± .02 3 PLC ± .010 4 PLC ± - ANGLES ± 2°		APPLICATION SPEC -	SIZE A3	CAGE CODE 00779
MATERIAL -	FINISH -	WEIGHT -	DRAWING NO C-61480	RESTRICTED TO -
CUSTOMER DRAWING			SCALE 6:1	SHEET 2 OF 2
			REV F	