

## 54LS193/DM54LS193/DM74LS193 Synchronous 4-Bit Up/Down Binary Counters with Dual Clock

### General Description

This circuit is a synchronous up/down 4-bit binary counter. Synchronous operation is provided by having all flip-flops clocked simultaneously, so that the outputs change together when so instructed by the steering logic. This mode of operation eliminates the output counting spikes normally associated with asynchronous (ripple-clock) counters.

The outputs of the four master-slave flip-flops are triggered by a low-to-high level transition of either count (clock) input. The direction of counting is determined by which count input is pulsed while the other count input is held high.

The counter is fully programmable; that is, each output may be preset to either level by entering the desired data at the inputs while the load input is low. The output will change independently of the count pulses. This feature allows the counters to be used as modulo-N dividers by simply modifying the count length with the preset inputs.

A clear input has been provided which, when taken to a high level, forces all outputs to the low level; independent of the count and load inputs. The clear, count, and load inputs are buffered to lower the drive requirements of clock drivers, etc., required for long words.

These counters were designed to be cascaded without the need for external circuitry. Both borrow and carry outputs are available to cascade both the up and down counting functions. The borrow output produces a pulse equal in width to the count down input when the counter underflows.

Similarly, the carry output produces a pulse equal in width to the count down input when an overflow condition exists. The counters can then be easily cascaded by feeding the borrow and carry outputs to the count down and count up inputs respectively of the succeeding counter.

### Features

- Fully independent clear input
- Synchronous operation
- Cascading circuitry provided internally
- Individual preset each flip-flop
- Alternate Military/Aerospace device (54LS193) is available. Contact a National Semiconductor Sales Office/Distributor for specifications.

### Connection Diagram

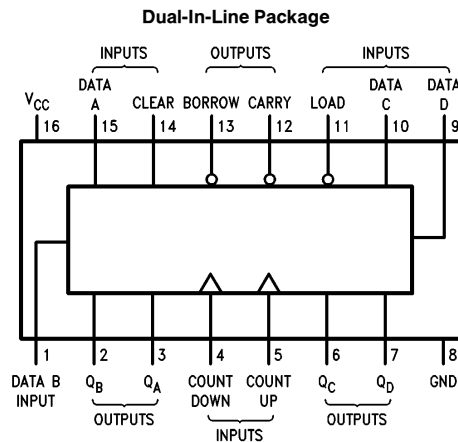

TL/F/6406-1

**Order Number 54LS193DMQB, 54LS193FMQB, 54LS193LMQB,  
DM54LS193J, DM54LS193W, DM74LS193M or DM74LS193N  
See NS Package Number E20A, J16A, M16A, N16E or W16A**

**54LS193/DM54LS193/DM74LS193 Synchronous 4-Bit Up/Down Counters with Dual Clock**

## Absolute Maximum Ratings (Note)

If Military/Aerospace specified devices are required, please contact the National Semiconductor Sales Office/Distributors for availability and specifications.

Supply Voltage	7V
Input Voltage	7V
Operating Free Air Temperature Range	
DM54LS and 54LS	−55°C to +125°C
DM74LS	0°C to +70°C
Storage Temperature Range	−65°C to +150°C

Note: The "Absolute Maximum Ratings" are those values beyond which the safety of the device cannot be guaranteed. The device should not be operated at these limits. The parametric values defined in the "Electrical Characteristics" table are not guaranteed at the absolute maximum ratings. The "Recommended Operating Conditions" table will define the conditions for actual device operation.

## Recommended Operating Conditions

Symbol	Parameter	DM54LS193			DM74LS193			Units
		Min	Nom	Max	Min	Nom	Max	
V <sub>CC</sub>	Supply Voltage	4.5	5	5.5	4.75	5	5.25	V
V <sub>IH</sub>	High Level Input Voltage	2			2			V
V <sub>IL</sub>	Low Level Input Voltage			0.7			0.8	V
I <sub>OH</sub>	High Level Output Current			−0.4			−0.4	mA
I <sub>OL</sub>	Low Level Output Current			4			8	mA
f <sub>CLK</sub>	Clock Frequency (Note 1)	0		25	0		25	MHz
	Clock Frequency (Note 2)	0		20	0		20	MHz
t <sub>W</sub>	Pulse Width of Any Input (Note 6)	20			20			ns
t <sub>SU</sub>	Data Setup Time (Note 6)	20			20			ns
t <sub>H</sub>	Data Hold Time (Note 6)	0			0			ns
t <sub>REL</sub>	Release Time (Note 6)	40			40			ns
T <sub>A</sub>	Free Air Operating Temperature	−55		125	0		70	°C

## Electrical Characteristics over recommended operating free air temperature range (unless otherwise noted)

Symbol	Parameter	Conditions	Min	Typ (Note 3)	Max	Units
V <sub>I</sub>	Input Clamp Voltage	V <sub>CC</sub> = Min, I <sub>I</sub> = −18 mA			−1.5	V
V <sub>OH</sub>	High Level Output Voltage	V <sub>CC</sub> = Min, I <sub>OH</sub> = Max	DM54	2.5	3.4	V
		V <sub>IL</sub> = Max, V <sub>IH</sub> = Min	DM74	2.7	3.4	
V <sub>OL</sub>	Low Level Output Voltage	V <sub>CC</sub> = Min, I <sub>OL</sub> = Max	DM54		0.25	V
		V <sub>IL</sub> = Max, V <sub>IH</sub> = Min	DM74		0.35	
		I <sub>OL</sub> = 4 mA, V <sub>CC</sub> = Min	DM74		0.25	
I <sub>I</sub>	Input Current @ Max Input Voltage	V <sub>CC</sub> = Max, V <sub>I</sub> = 7V			0.1	mA
I <sub>IH</sub>	High Level Input Current	V <sub>CC</sub> = Max, V <sub>I</sub> = 2.7V			20	μA
I <sub>IL</sub>	Low Level Input Current	V <sub>CC</sub> = Max, V <sub>I</sub> = 0.4V			−0.4	mA
I <sub>OS</sub>	Short Circuit Output Current	V <sub>CC</sub> = Max (Note 4)	DM54	−20	−100	mA
			DM74	−20	−100	
I <sub>CC</sub>	Supply Current	V <sub>CC</sub> = Max (Note 5)		19	34	mA

Note 1: C<sub>L</sub> = 15 pF, R<sub>L</sub> = 2 kΩ, I<sub>A</sub> = 25°C and V<sub>CC</sub> = 5V.

Note 2: C<sub>L</sub> = 50 pF, R<sub>L</sub> = 2 kΩ, I<sub>A</sub> = 25°C and V<sub>CC</sub> = 5V.

Note 3: All typicals are at V<sub>CC</sub> = 5V, T<sub>A</sub> = 25°C.

Note 4: Not more than one output should be shorted at a time, and the duration should not exceed one second.

Note 5: I<sub>CC</sub> is measured with all outputs open, CLEAR and LOAD inputs grounded, and all other inputs at 4.5V.

Note 6: T<sub>A</sub> = 25°C and V<sub>CC</sub> = 5V.

**Switching Characteristics** at  $V_{CC} = 5V$  and  $T_A = 25^\circ C$  (See Section 1 for Test Waveforms and Output Load)

Symbol	Parameter	From (Input) To (Output)	$R_L = 2\text{ k}\Omega$				Units
			$C_L = 15\text{ pF}$		$C_L = 50\text{ pF}$		
			Min	Max	Min	Max	
$f_{MAX}$	Maximum Clock Frequency		25		20		MHz
$t_{PLH}$	Propagation Delay Time Low to High Level Output	Count Up to Carry		26		30	ns
$t_{PHL}$	Propagation Delay Time High to Low Level Output	Count Up to Carry		24		36	ns
$t_{PLH}$	Propagation Delay Time Low to High Level Output	Count Down to Borrow		24		29	ns
$t_{PHL}$	Propagation Delay Time High to Low Level Output	Count Down to Borrow		24		32	ns
$t_{PLH}$	Propagation Delay Time Low to High Level Output	Either Count to Any Q		38		45	ns
$t_{PHL}$	Propagation Delay Time High to Low Level Output	Either Count to Any Q		47		54	ns
$t_{PLH}$	Propagation Delay Time Low to High Level Output	Load to Any Q		40		41	ns
$t_{PHL}$	Propagation Delay Time High to Low Level Output	Load to Any Q		40		47	ns
$t_{PHL}$	Propagation Delay Time High to Low Level Output	Clear to Any Q		35		44	ns

# Logic Diagram

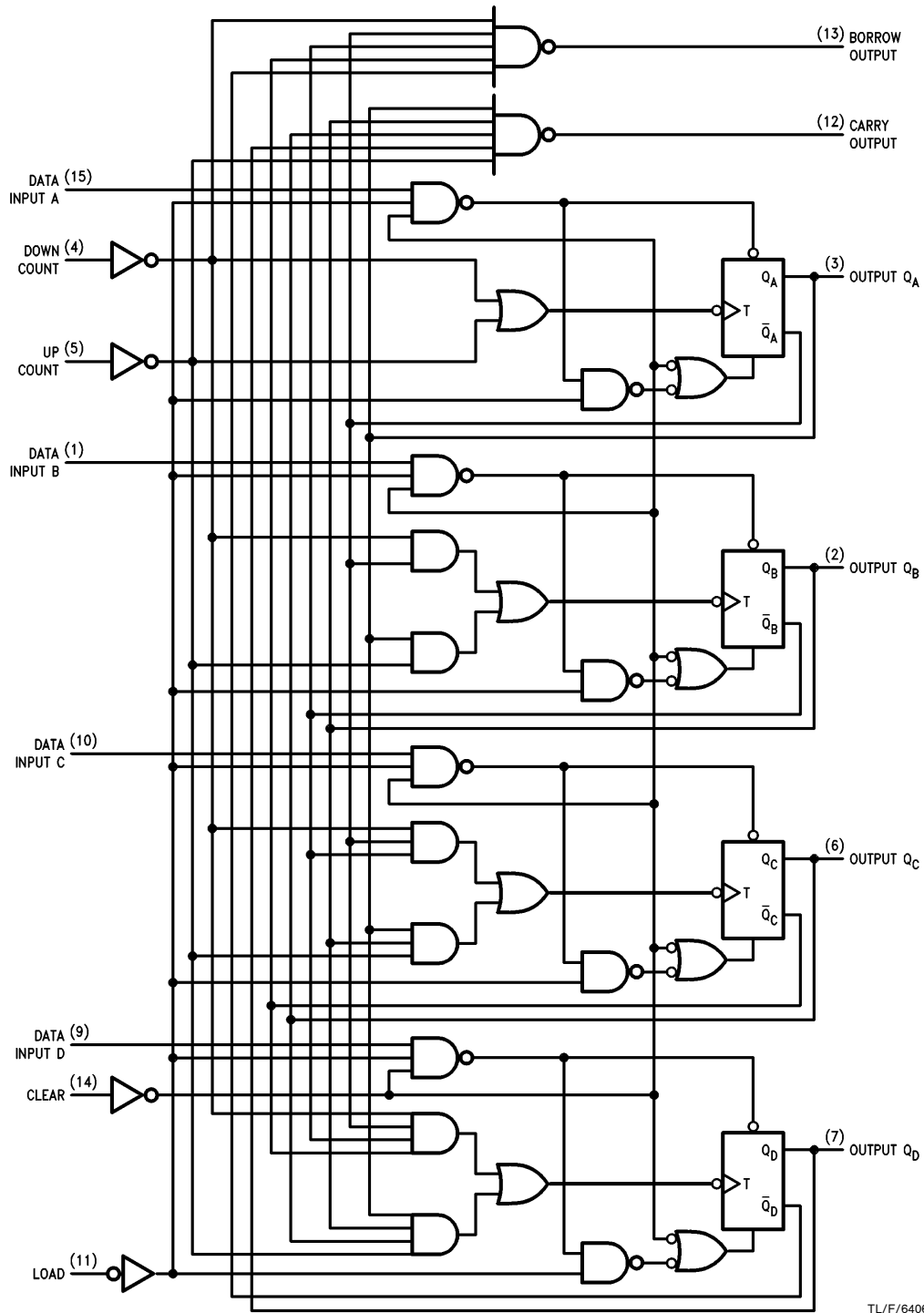

TL/F/6406-2

# Timing Diagrams

Typical Clear, Load, and Count Sequences

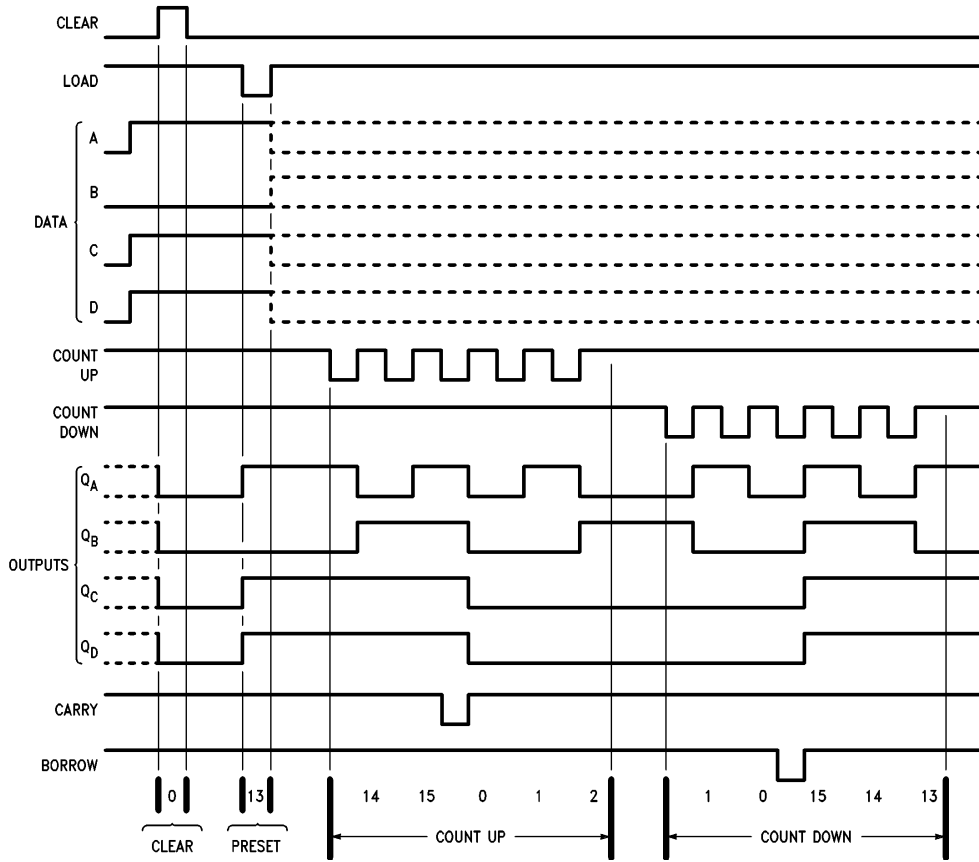

TL/F/6406-3

**Note A:** Clear overrides load, data, and count inputs.

**Note B:** When counting up, count-down input must be high; when counting down, count-up input must be high.

**Physical Dimensions** inches (millimeters)

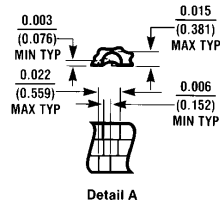
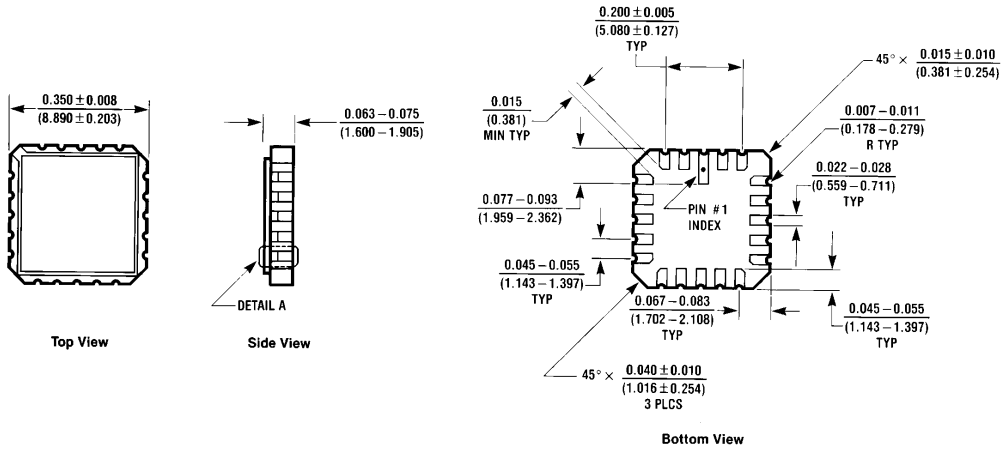

**Ceramic Leadless Chip Carrier Package (E)**  
**Order Number 54LS193LMQB**  
**NS Package Number E20A**

E20A (REV D)

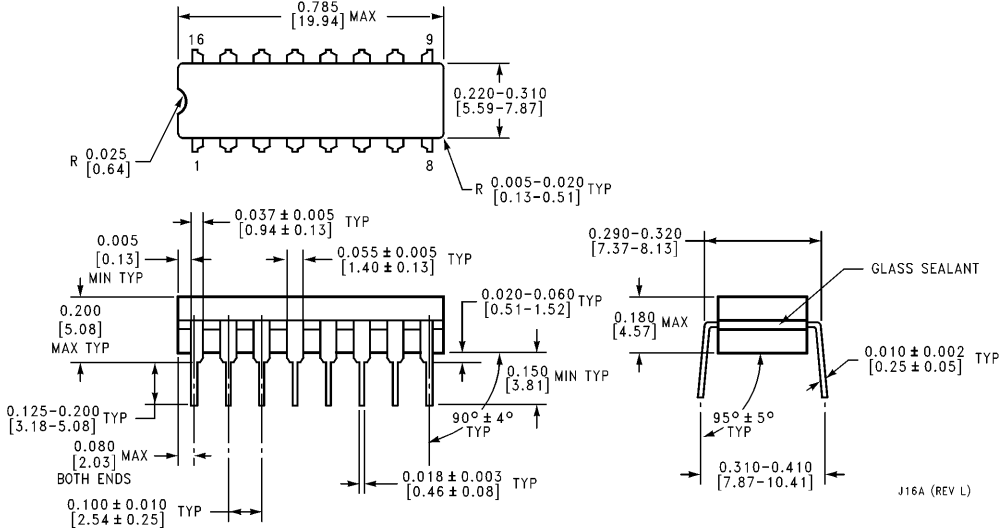

**16-Lead Ceramic Dual-In-Line Package (J)**  
**Order Number 54LS193DMQB or DM54LS193J**  
**NS Package Number J16A**

J16A (REV L)

**Physical Dimensions** inches (millimeters) (Continued)

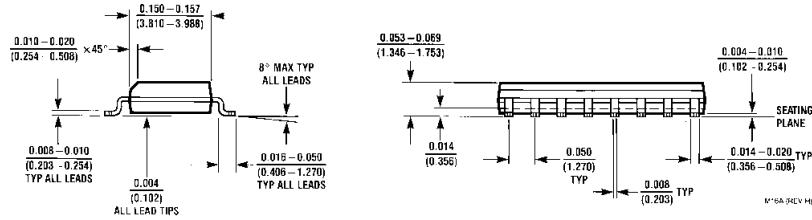
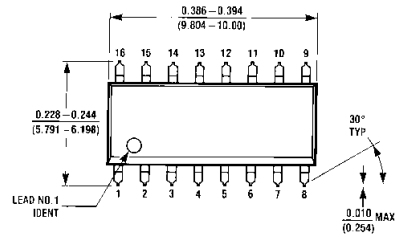

**16-Lead Small Outline Molded Package (M)**  
**Order Number DM74LS193M**  
**NS Package Number M16A**

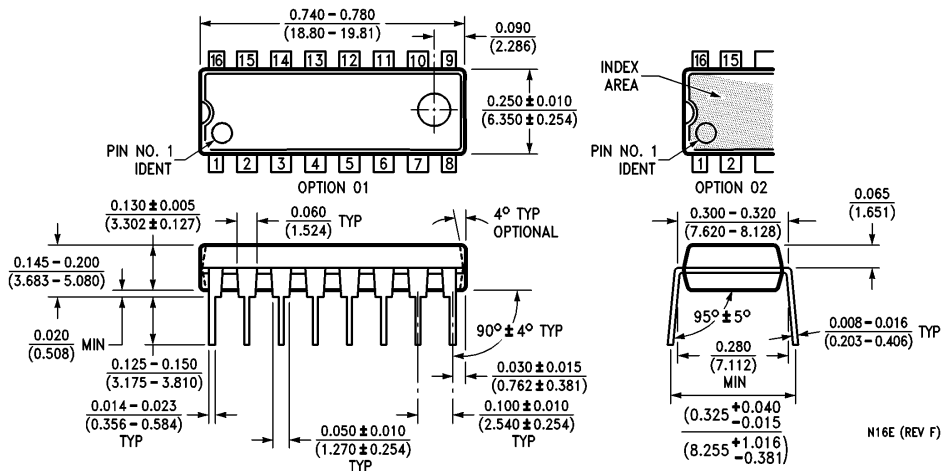

**16-Lead Molded Dual-In-Line Package (N)**  
**Order Number DM74LS193N**  
**NS Package Number N16E**

**Physical Dimensions** inches (millimeters) (Continued)

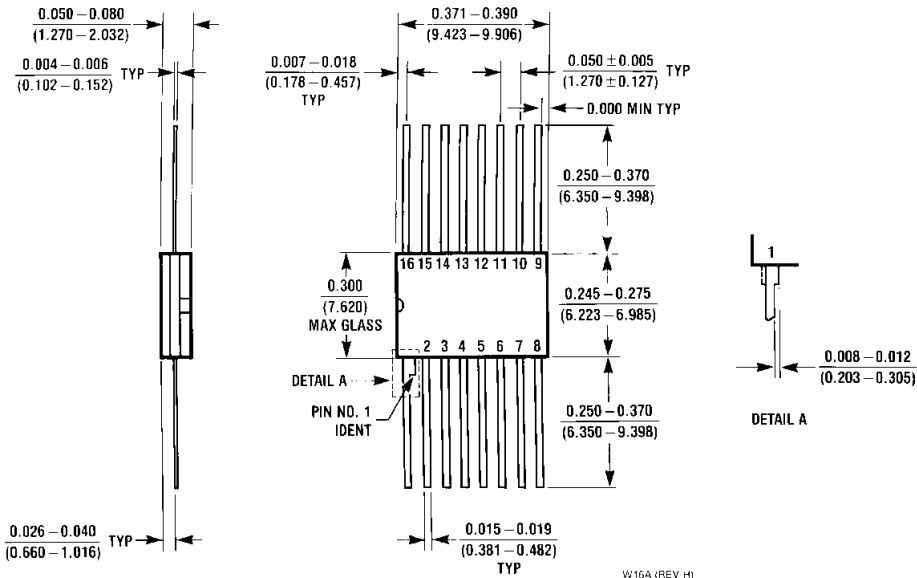

**16-Lead Ceramic Flat Package (W)**  
**Order Number 54LS193FMQB or DM54LS193W**  
**NS Package Number W16A**

**LIFE SUPPORT POLICY**

NATIONAL'S PRODUCTS ARE NOT AUTHORIZED FOR USE AS CRITICAL COMPONENTS IN LIFE SUPPORT DEVICES OR SYSTEMS WITHOUT THE EXPRESS WRITTEN APPROVAL OF THE PRESIDENT OF NATIONAL SEMICONDUCTOR CORPORATION. As used herein:

1. Life support devices or systems are devices or systems which, (a) are intended for surgical implant into the body, or (b) support or sustain life, and whose failure to perform, when properly used in accordance with instructions for use provided in the labeling, can be reasonably expected to result in a significant injury to the user.
2. A critical component is any component of a life support device or system whose failure to perform can be reasonably expected to cause the failure of the life support device or system, or to affect its safety or effectiveness.



**National Semiconductor Corporation**  
 1111 West Bardin Road  
 Arlington, TX 76017  
 Tel: 1(800) 272-9959  
 Fax: 1(800) 737-7018

**National Semiconductor Europe**  
 Fax: (+49) 0-180-530 85 86  
 Email: onjwge@tevm2.nsc.com  
 Deutsch Tel: (+49) 0-180-530 85 85  
 English Tel: (+49) 0-180-532 78 32  
 Français Tel: (+49) 0-180-532 93 58  
 Italiano Tel: (+49) 0-180-534 16 80

**National Semiconductor Hong Kong Ltd.**  
 19th Floor, Straight Block,  
 Ocean Centre, 5 Canton Rd.  
 Tsimshatsui, Kowloon  
 Hong Kong  
 Tel: (852) 2737-1600  
 Fax: (852) 2736-9960

**National Semiconductor Japan Ltd.**  
 Tel: 81-043-299-2309  
 Fax: 81-043-299-2408

National does not assume any responsibility for use of any circuitry described, no circuit patent licenses are implied and National reserves the right at any time without notice to change said circuitry and specifications.