

REVISION HISTORY				
REV	DESCRIPTION	DATE	BY	CHG No
0	FIRST ISSUE	03/04/09	B.Z	8815

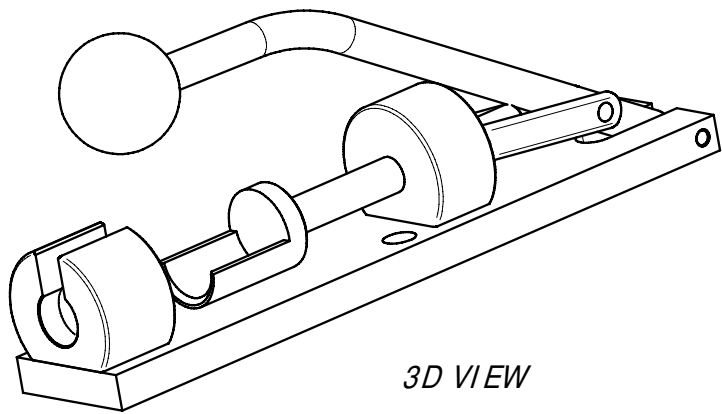

3D VIEW

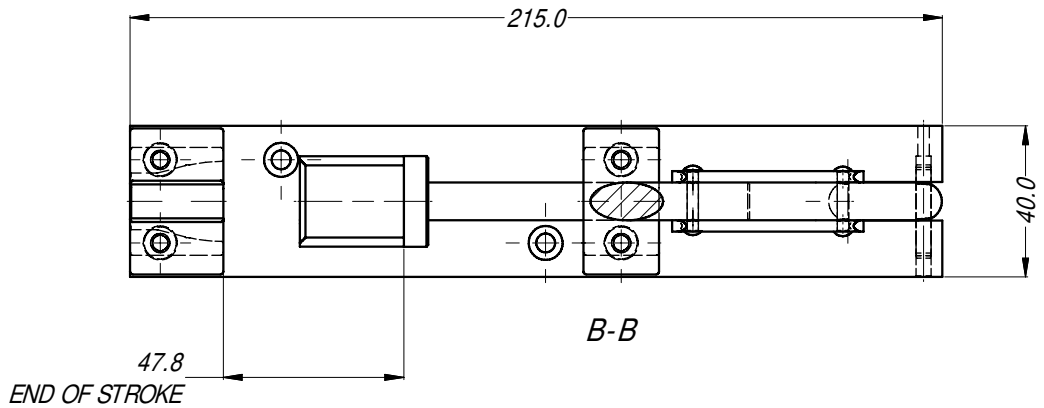
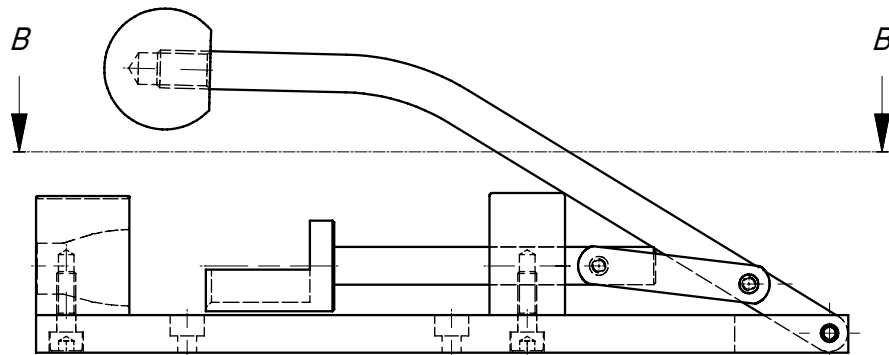

UNLESS OTHERWISE SPECIFIED TOLERANCE TO BE		THIS DOCUMENT IS THE PROPERTY OF AMPHENOL AUSTRALIA PTY. LTD. NO PART THEREOF MAY BE REPRODUCED AND USED WITHOUT THE PRIOR WRITTEN CONSENT OF THE OWNER		Amphenol Amphenol Australia Pty.Ltd, 2 Fiveways Blvd, Keysborough, VIC 3173	
LINER	ANGULAR	MATERIAL:	DRN:	DATE:	TITLE:
X ± 0.5	X' ± 1	ALUMINUM & STEEL	B Z	12/12/09	AX SERIES ASSEMBLY TOOL CUSTOMER DWG
X.X ± 0.1	X.X' ± 30'	FINISH: NICKEL PLATE	CKD:	12/03/09	PART No: T2890
X.XX ± 0.05	X.XX' ± 15'	DO NOT SCALE	APP'D:	12/03/09	DRAWING NO. 52930003-704-2
BREAK ALL SHARP EDGES AND REMOVE ALL BURRS		DIMENSIONS IN MILLIMETRES	SCALE: 1:2	SIZE: A4	SHEET 2/2
		THIRD ANGLE PROJECTION		CAD FILE: 52930003704211	