



SANYO Semiconductors

DATA SHEET

An ON Semiconductor Company

LC88F52H0A — CMOS LSI FROM 512K byte, RAM 24K byte on-chip 16-bit 1-chip Microcontroller

Overview

The SANYO LC88F52H0A is a 16-bit microcomputer that, centered around an Xstromy16 CPU, integrates on a single chip a number of hardware features such as 512K-byte flash ROM (onboard programmable), 24K-byte RAM, eight 16-bit timers, a base timer serving as a time-of-day clock, a real time clock, two synchronous SIO interfaces with automatic transmission capability, two single master I²C/synchronous SIO interface, a slave I²C/synchronous SIO interface, four asynchronous SIO (UART) interfaces, a 16-channel 12-bit resolution AD converter, 8bit resolution DA converter, four multifrequency 12-bit PWM modules, a watchdog timer, a system clock frequency divider, a 59-source (32 modules) 14-vector interrupt feature, and on-chip debugger feature.

Features

- Xstromy16 CPU
 - 4G-byte address space
 - General-purpose registers: 16 bits × 16 registers
- Flash ROM
 - Capable of onboard programming with a wide range of voltage levels (3.0 to 5.5V).
 - Block-erasable in 512 or 1K byte units.
 - Data written in 2-byte units.
 - 524288 × 8 bits
- RAM
 - 24576 × 8 bits

* This product is licensed from Silicon Storage Technology, Inc. (USA), and manufactured and sold by SANYO Semiconductor Co., Ltd.

- Any and all SANYO Semiconductor Co., Ltd. products described or contained herein are, with regard to "standard application", intended for the use as general electronics equipment (home appliances, AV equipment, communication device, office equipment, industrial equipment etc.). The products mentioned herein shall not be intended for use for any "special application" (medical equipment whose purpose is to sustain life, aerospace instrument, nuclear control device, burning appliances, transportation machine, traffic signal system, safety equipment etc.) that shall require extremely high level of reliability and can directly threaten human lives in case of failure or malfunction of the product or may cause harm to human bodies, nor shall they grant any guarantee thereof. If you should intend to use our products for applications outside the standard applications of our customer who is considering such use and/or outside the scope of our intended standard applications, please consult with us prior to the intended use. If there is no consultation or inquiry before the intended use, our customer shall be solely responsible for the use.
- Specifications of any and all SANYO Semiconductor Co., Ltd. products described or contained herein stipulate the performance, characteristics, and functions of the described products in the independent state, and are not guarantees of the performance, characteristics, and functions of the described products as mounted in the customer's products or equipment. To verify symptoms and states that cannot be evaluated in an independent device, the customer should always evaluate and test devices mounted in the customer's products or equipment.

■ Minimum instruction cycle time (tCYC)

- 83.3 ns (12MHz) $V_{DD} = 4.5$ to $5.5V$
- 107 ns (9.3MHz) $V_{DD} = 3.0$ to $5.5V$
- 500 ns (2MHz) $V_{DD} = 2.5$ to $5.5V$

■ Ports

- Normal withstand voltage I/O ports
Ports whose I/O direction can be designated in 1 bit units : 86 (P0n P1n, P2n, P3n, P4n, P5n, P6n, P7n, PAn PB0 to PB6, PC2, PD0 to PD5)
- Oscillation/normal withstand voltage I/O ports : 4 (PC0, PC1, PC3, PC4)
- Reset pins : 1 (RESB)
- TEST pins : 1 (TEST)
- Power pins : 8 (V_{SS1} to 4, V_{DD1} to 4)

■ Timers

- Timer 0: 16-bit timer that supports PWM/toggle outputs
 - 1) 5-bit prescaler
 - 2) 8-bit PWM $\times 2$, 8-bit timer + 8-bit PWM mode selectable
 - 3) Clock source selectable from system clock, OSC0, OSC1, and internal RC oscillator
- Timer 1: 16-bit timer with capture registers
 - 1) 5-bit prescaler
 - 2) May be divided into 2 channels of 8-bit timer
 - 3) Clock source selectable from system clock, OSC0, OSC1, and internal RC oscillator
- Timer 2: 16-bit timer with capture registers
 - 1) 4-bit prescaler
 - 2) May be divided into 2 channels of 8-bit timer
 - 3) Clock source selectable from system clock, OSC0, OSC1, and external events
- Timer 3: 16-bit timer that supports PWM/toggle outputs
 - 1) 8-bit prescaler
 - 2) 8-bit timer $\times 2$ ch or 8-bit timer + 8-bit PWM mode selectable
 - 3) Clock source selectable from system clock, OSC0, OSC1, and external events
- Timer 4: 16-bit timer that supports toggle outputs
 - 1) Clock source selectable from system clock and prescaler 0
- Timer 5: 16-bit timer that supports toggle outputs
 - 1) Clock source selectable from system clock and prescaler 0
- Timer 6: 16-bit timer that supports toggle outputs
 - 1) Clock source selectable from system clock and prescaler 1
- Timer 7: 16-bit timer that supports toggle outputs
 - 1) Clock source selectable from system clock and prescaler 1

* Prescaler 0 and 1 are consisted of 4 bits and can choose their clock source from OSC0 or OSC1.
- Base timer
 - 1) Clock may be selected from OSC0 (32.768kHz crystal oscillator) and frequency-divided output of system clock.
 - 2) Interrupts can be generated in 7 timing schemes.

■ Real time clock

- 1) Calender with Jan. 1, 2000 to Dec.31, 2799 including automatic leap year calculation function.
- 2) Consisted of Independent second- minute-hour-day-month-year-century counters.
- 3) Programmable count-clock calibration function.

■ Serial interfaces

- SIO0: 8-bit synchronous SIO
 - 1) LSB first/MSB first mode selectable
 - 2) Supports data communication with a data length of 8 bits or less (1 to 8 bits specifiable)
 - 3) Built-in 8-bit baudrate generator (4 tCYC to 512 tCYC transfer clocks)
 - 4) Continuous/automatic data transmission (9- to 32768-bit units specifiable)
 - 5) Interval function (intervals specifiable in 0 to 64 tSCK units)
 - 6) Wakeup function
- SIO1: 8-bit synchronous SIO
 - 1) LSB first/MSB first mode selectable
 - 2) Supports data communication with a data length of 8 bits or less (1 to 8 bits specifiable)
 - 3) Built-in 8-bit baudrate generator (4 tCYC to 512 tCYC transfer clocks)
 - 4) Continuous/automatic data transmission (9- to 32768-bit units specifiable)
 - 5) Interval function (intervals specifiable in 0 to 64 tSCK units)
 - 6) Wakeup function
- SMIIC0: Single master I²C/8-bit synchronous SIO
 - Mode 0: Single-master mode communication
 - Mode 1: Synchronous 8-bit serial I/O (MSB first)
- SMIIC1: Single master I²C/8-bit synchronous SIO
 - Mode 0: Single-master mode communication
 - Mode 1: Synchronous 8-bit serial I/O (MSB first)
- SLIIC0: Slave I²C/8-bit synchronous SIO
 - Mode 0: I²C slave mode communication
 - Mode 1: Synchronous 8-bit serial I/O (MSB first)

Note: usable only with the external clock source
- UART0
 - 1) Data length : 8 bits (LSB first)
 - 2) Start bits : 1 bit
 - 3) Stop bits : 1 bit
 - 4) Parity bits : None/even parity/odd parity
 - 5) Transfer rate : 4/8 cycle
 - 6) Baudrate source clock: P07 input signal used as a 1 cycle signal (TOPWMH can be used as a clock source) or Timer 4 cycle.
 - 7) Full duplex communication

Note: The “cycle” refers to one period of the baudrate clock source.
- UART2
 - 1) Data length : 8 bits (LSB first)
 - 2) Start bits : 1 bit
 - 3) Stop bits : 1/2 bit
 - 4) Parity bits : None/even parity/odd parity
 - 5) Transfer rate : 8 to 4096 cycle
 - 6) Baudrate source clock : System clock/OSC0/OSC1/P26 input signal
 - 7) Wakeup function
 - 8) Full duplex communication

Note: The “cycle” refers to one period of the baudrate clock source.
- UART3
 - 1) Data length : 8 bits (LSB first)
 - 2) Start bits : 1 bit
 - 3) Stop bits : 1/2 bit
 - 4) Parity bits : None/even parity/odd parity
 - 5) Transfer rate : 8 to 4096 cycle
 - 6) Baudrate source clock: System clock/OSC0/OSC1/P36 input signal
 - 7) Wakeup function
 - 8) Full duplex communication

Note: The “cycle” refers to one period of the baudrate clock source.

• UART4

- 1) Data length : 8 bits (LSB first)
- 2) Start bits : 1 bit
- 3) Stop bits : 1/2 bit
- 4) Parity bits : None/even parity/odd parity
- 5) Transfer rate : 8 to 4096 cycle
- 6) Baudrate source clock: System clock/OSC0/OSC1/P37 input signal
- 7) Wakeup function
- 8) Full duplex communication

Note: The “cycle” refers to one period of the baudrate clock source.

■ AD converter

- 1) 12/8 bits resolution selectable
- 2) Analog input: 16 channels
- 3) Comparator mode
- 4) Automatic reference voltage generation

■ DA converter

- 1) 8 bits resolution
- 2) 2 converters built-in
- 3) Able to choose output pins

■ PWM

- PWM0: Multifrequency 12-bit PWM × 2 channels (PWM00 and PWM01)
 - 1) 2-channel pairs controlled independently of one another
 - 2) Clock source selectable from system clock or OSC1
 - 3) 8-bit prescaler: $TPWMR0 = (\text{prescaler value} + 1) \times \text{clock period}$
 - 4) 8-bit fundamental wave PWM generator circuit + 4-bit additional pulse generator circuit
 - 5) Fundamental wave PWM mode
 - Fundamental wave period: 16 TPWMR0 to 256 TPWMR0
 - High pulse width : 0 to (Fundamental wave period - TPWMR0)
 - 6) Fundamental wave + additional pulse mode
 - Fundamental wave period: 16 TPWMR0 to 256 TPWMR0
 - Overall period : Fundamental wave period × 16
 - High pulse width : 0 to (Fundamental wave period - TPWMR0)
- PWM1: Multifrequency 12-bit PWM × 2 channels (PWM10 and PWM11)
 - 1) 2-channel pairs controlled independently of one another
 - 2) Clock source selectable from system clock or OSC1
 - 3) 8-bit prescaler: $TPWMR1 = (\text{prescaler value} + 1) \times \text{clock period}$
 - 4) 8-bit fundamental wave PWM generator circuit + 4-bit additional pulse generator circuit
 - 5) Fundamental wave PWM mode
 - Fundamental wave period: 16 TPWMR1 to 256 TPWMR1
 - High pulse width : 0 to (Fundamental wave period - TPWMR1)
 - 6) Fundamental wave + additional pulse mode
 - Fundamental wave period: 16 TPWMR1 to 256 TPWMR1
 - Overall period : Fundamental wave period × 16
 - High pulse width : 0 to (Fundamental wave period - TPWMR1)

■ Watchdog timer

- 1) Driven by the base timer + internal watchdog timer dedicated counter
- 2) Interrupt or reset mode selectable

■ Interrupts (peripheral function)

- 59 sources (32 modules), 14 vector addresses

- 1) Provides three levels (low (L), high (H), and highest (X)) of multiplex interrupt control. Any interrupt requests of the level equal to or lower than the current interrupt are not accepted.
- 2) When interrupt requests to two or more vector addresses occur at the same time, the interrupt of the highest level takes precedence over the other interrupts. For interrupts of the same level, the interrupt into the smallest vector address takes precedence.

No.	Vector Address	Interrupt Source
1	08000H	Watchdog timer (1)
2	08004H	Base timer (2)
3	08008H	Timer 0 (2)
4	0800CH	INT0 (1)
5	08014H	INT1 (1)
6	08018H	INT2 (1)/timer 1 (2)/UART2 (4)
7	0801CH	INT3 (1)/timer 2 (4)/SMIIC0 (1)/SLIIC1 (1)
8	08020H	INT4 (1)/timer 3 (2)
9	08024H	INT5 (1)/timer 4 (1)/SIO1 (2)
10	0802CH	PWM0 (1)/SMIIC1(1)
11	08030H	ADC (1)/timer 5 (1)
12	08034H	INT6 (1)/timer 6 (1)/UART 3 (4)
13	08038H	INT7 (1)/SIO0 (2)/SIO0(2)/USRT4 (4)
14	0803CH	Port 0 (3)/Port 5 (8)/RTC (1)

- 3 priority levels selectable.
- Of interrupts of the same level, the one with the smallest vector address takes precedence.
- A number enclosed in parentheses denotes the number of sources.

■ Subroutine Stack: 24K-byte RAM area

- Subroutine calls that automatically save PSW, interrupt vector calls: 6 bytes
- Subroutine calls that do not automatically save PSW: 4 bytes

■ Multiplication/division instructions

- 16 bits × 16 bits (18 tCYC execution time)
- 16 bits ÷ 16 bits (18 to 19 tCYC execution time)
- 32 bits ÷ 16 bits (18 to 19 tCYC execution time)

■ Oscillator circuits

- RC oscillator circuit (internal): For system clock
- CF oscillator circuit (built-in Rf circuit): For system clock (OSC1)
- VCO oscillator circuit: For system clock (OSC1)
- Crystal oscillator circuit (built-in Rf circuit): For low-speed system clock (OSC0)
- SLRC oscillator circuit (internal): For system clock (In the case of exception processing)

■ System clock divider function

- Can run on low current.
- 1/1 to 1/128 of the system clock frequency can be set.

LC88F52H0A

■ Standby Function

- HALT mode: Halts instruction execution while allowing the peripheral circuits to continue operation.
 - 1) Oscillation is not halted automatically.
 - 2) Released by a system reset or occurrence of an interrupt.
- HOLD mode: Suspends instruction execution and the operation of the peripheral circuits.
 - 1) OSC1, RC and OSC0 oscillators automatically stop.
 - 2) There are the six ways of releasing the HOLD mode.
 - (1) Setting the reset pin to the low level
 - (2) Setting at least one of the INT0, INT1, INT2, INT4, INT5, INT6, and INT7 pins to the specified level
 - (3) Having an interrupt source established at port 0
 - (4) Having an interrupt source established at port 5
 - (5) Having an interrupt established at SIO0 or SIO1
 - (6) Having an interrupt established at UART2, UART3 or UART4
- HOLDX mode: Suspends instruction execution and the operation of the peripheral circuits except those which run on OSC0.
 - 1) OSC1 and RC oscillations automatically stop.
 - 2) OSC0 maintains the state that is established when the HOLDX mode is entered.
 - 3) There are seven ways of releasing the HOLDX mode.
 - (1) Setting the reset pin to the low level
 - (2) Setting at least one of the INT0, INT1, INT2, INT4, INT5, INT6, and INT7 pins to the specified level
 - (3) Having an interrupt source established at port 0
 - (4) Having an interrupt source established at port 5
 - (5) Having an interrupt source established at the base timer circuit
 - (6) Having an interrupt established at SIO0 or SIO1
 - (7) Having an interrupt established at UART2, UART3 or UATR4

■ On-chip debugger function

- Supports software debugging with the IC mounted on the target board.
- Supports source line debugging and tracing functions, and breakpoint setting and real time display.
- Single-wire communication

■ Package Form

- TQFP100(14×14): Lead-free and halogen-free type

■ Development Tools

- On-chip debugger: EOCUIF1 + LC88F52H0A

■ Programming board

Package	Programming Board
TQFP100 (14 × 14)	W88F52TQ

■ Flash Programming

Manufacturer	Model Name	Supported Version	Device
Flash Support Group (single)	AF9708/09/09B/09C	Revision: After Rev.03.32D	88F512SN
Flash Support Group (Gang)	AF9723/23B		
	AF9833		
SANYO	SKK/SKK Type-B	Application Version After 1.06 Chip Data Version After 2.22	LC88F52H0A

LC88F52H0A

Pin Assignment

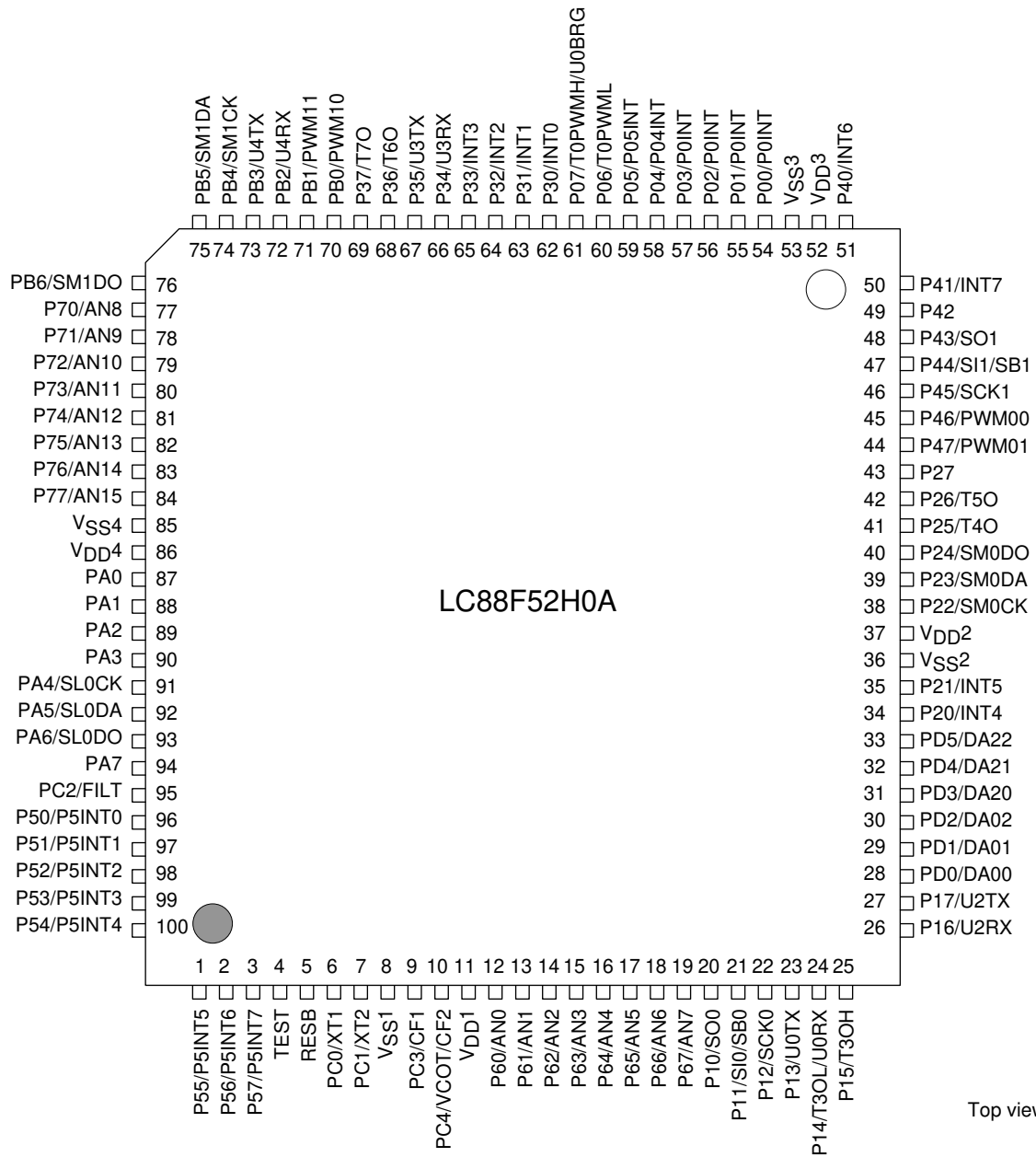

Top view

SANYO: TQFP100 (14×14) (Lead-free and halogen-free type)

System Block Diagram

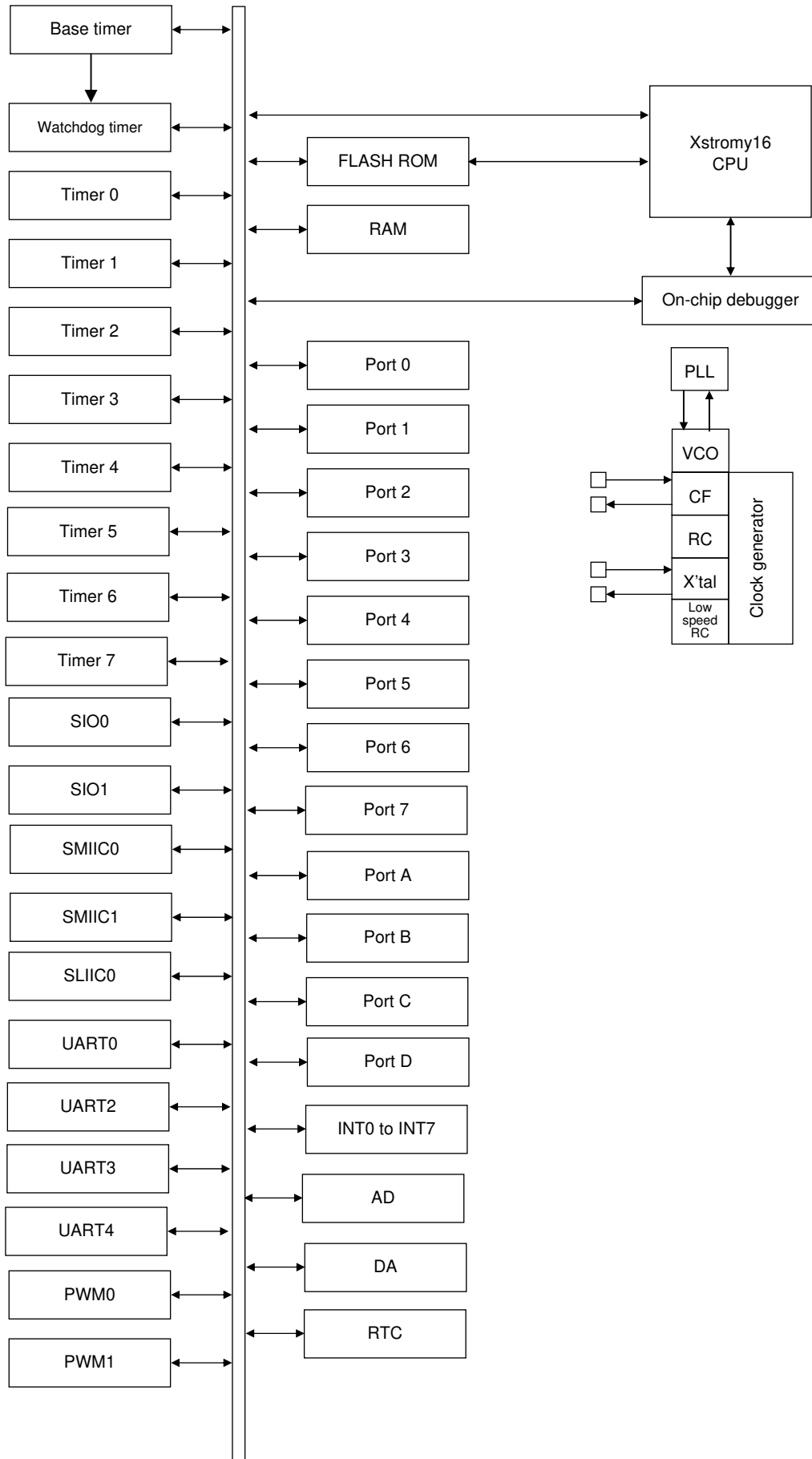

LC88F52H0A

Pin Description

Pin Name	I/O	Description
V _{SS1} , V _{SS2} , V _{SS3} , V _{SS4}	-	- Power sources
V _{DD1} , V _{DD2} , V _{DD3} , V _{DD4}	-	+ Power sources
Port 0 P00 to P07	I/O	<ul style="list-style-type: none"> • 8-bit I/O port • I/O specifiable in 1-bit units • Pull-up resistors can be turned on and off in 1 bit units • HOLD release input (P00 to P03, P04, P05) • Port 0 interrupt input (P00 to P03, P04, P05) • Pin functions <ul style="list-style-type: none"> P06: Timer 0L output P07: Timer 0L output/UART0 clock input
Port 1 P10 to P17	I/O	<ul style="list-style-type: none"> • 8-bit I/O port • I/O specifiable in 1-bit units • Pull-up resistors can be turned on and off in 1 bit units • Pin functions <ul style="list-style-type: none"> P10: SIO0 data output P11: SIO0 data input/pulse input/output P12: SIO0 clock input/output P13: UART0 transmit P14: Timer 3L output/UART0 receive P15: Timer 3H output P16: UART2 receive P17: UART2 transmit
Port 2 P20 to P27	I/O	<ul style="list-style-type: none"> • 8-bit I/O port • I/O specifiable in 1-bit units • Pull-up resistors can be turned on and off in 1 bit units • Pin functions <ul style="list-style-type: none"> P20: INT4 input/HOLD release input/timer 3 event input/timer 2L capture input/timer 2H capture input P21: INT5 input/HOLD release input/timer 3 event input/timer 2L capture input/timer 2H capture input P22: SMIC0 clock input/output P23: SMIC0 bus input/output/data input P24: SMIC0 data output (used in 3-wire SIO mode) P25: Timer 4 output P26: Timer 5 output Interrupt acknowledge type INT4, INT5: H level, L level, H edge, L edge, both edges
Port 3 P30 to P37	I/O	<ul style="list-style-type: none"> • 8-bit I/O port • I/O specifiable in 1-bit units • Pull-up resistors can be turned on and off in 1 bit units • Pin functions <ul style="list-style-type: none"> P30: INT0 input/HOLD release/timer 2L capture input P31: INT1 input/HOLD release/timer 2H capture input P32: INT2 input/HOLD release/timer 2 event input/timer 2L capture input P33: INT3 input/HOLD release/timer 2 event input/timer 2H capture input P34: UART3 receive P35: UART3 transmit P36: Timer 6 output P37: Timer 7 output Interrupt acknowledge type INT0 to INT3: H level, L level, H edge, L edge, both edges

Continued on next page.

LC88F52H0A

Continued from preceding page.

Pin Name	I/O	Description
Port 4 P40 to P47	I/O	<ul style="list-style-type: none"> • 8-bit I/O port • I/O specifiable in 1-bit units • Pull-up resistors can be turned on and off in 1 bit units • Pin functions P40: INT6 input/HOLD release input P41: INT7 input/HOLD release input P43: SIO1 data output P44: SIO1 data input/bus input/output P45: SIO1 clock input/output P46: PWM00 output P47: PWM01 output Interrupt acknowledge type INT6, INT7: H level, L level, H edge, L edge, both edges
Port 6 P60 to P67	I/O	<ul style="list-style-type: none"> • 8-bit I/O port • I/O specifiable in 1-bit units • Pull-up resistors can be turned on and off in 1 bit units • Pin functions AN0 (P60) to AN7 (P67): AD converter input port
Port 7 P70 to P77	I/O	<ul style="list-style-type: none"> • 8-bit I/O port • I/O specifiable in 1-bit units • Pull-up resistors can be turned on and off in 1 bit units • Pin functions AN8 (P70) to AN15 (P77): AD converter input port
Port A PA0 to PA7	I/O	<ul style="list-style-type: none"> • 8-bit I/O port • I/O specifiable in 1-bit units • Pull-up resistors can be turned on and off in 1 bit units • Multiplexed pin functions PA4: SLIIC0 clock input PA5: SLIIC0 bus input/output/data input PA6: SLIIC0 data output (used in 3-wire SIO mode)
Port B PB0 to PB6	I/O	<ul style="list-style-type: none"> • 7-bit I/O port • I/O specifiable in 1-bit units • Pull-up resistors can be turned on and off in 1 bit units • Multiplexed pin functions PB0: PWM10 output PB1: PWM11 output PB2: UART4 receive PB3: UART4 transmit PB4: SMIIC1 clock input/output PB5: SMIIC1 bus input/output/data input PB6: SMIIC1 data output (used in 3-wire SIO mode)
Port C PC0 to PC4	I/O	<ul style="list-style-type: none"> • 5-bit I/O port • I/O specifiable in 1-bit units • Pull-up resistors can be turned on and off in 1 bit units (PC2) • Pin functions PC0: 32.768 kHz crystal oscillator input PC1: 32.768 kHz crystal oscillator output PC2: FILT PC3: Ceramic oscillator input PC4: Ceramic oscillator output/VCO output
Port D PD0 to PD5	I/O	<ul style="list-style-type: none"> • 6-bit I/O port • I/O specifiable in 1-bit units • Pull-up resistors can be turned on and off in 1 bit units • Multiplexed pin functions PD0: DA00 output PD1: DA01 output PD2: DA02 output PD3: DA10 output PD4: DA11 output PD5: DA12 output
TEST	I/O	<ul style="list-style-type: none"> • TEST pin • Used to communicate with on-chip debugger. • Connects an external 100kΩ pull-down resistor.
RESB	I	Reset pin

Port Output Types

The table below lists the types of port outputs and the presence/absence of a pull-up resistor.

Data can be read into any input port even if it is in the output mode.

Port Name	Option Selected in Units of	Output Type	Pull-up Resistor
P00 to P07	1 bit	CMOS	Programmable
P10 to P17 P20 to P27 P30 to P37 P40 to P47 P50 to P57 P60 to P67 P70 to P77 PA0 to PA7 PB0 to PB6		Able to program special functions' output type from CMOS output or N-channel open drain	
P60 to P67 P70 to p77 PD0 to PD5 PC2		CMOS	
PC0	-	N-channel open drain (32.768kHz crystal oscillator input)	None
PC1	-	N-channel open drain (32.768kHz crystal oscillator output)	None
PC3	-	CMOS (ceramic oscillator input)	None
PC4	-	CMOS (ceramic oscillator output)	None

* Make the following connection to minimize the noise input to the V_{DD1} pin and prolong the backup time. Be sure to electrically short the V_{SS1}, V_{SS2}, V_{SS3} and V_{SS4} pins.

Example 1: When data is being backed up in the HOLD mode, the H level signals to the output ports are fed by the backup capacitors.

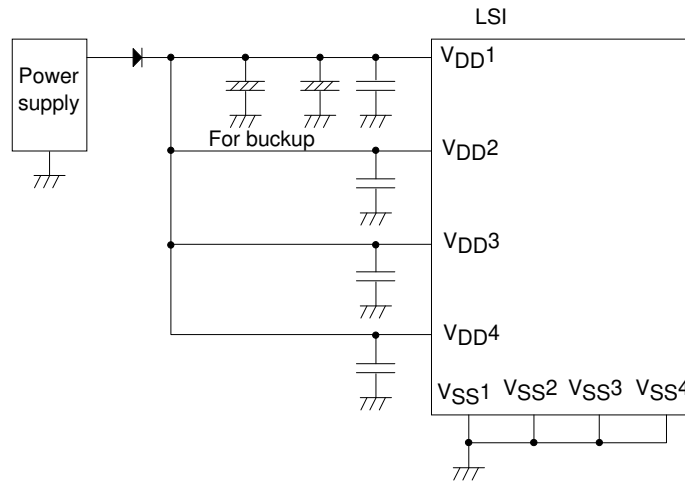

Example 2: When data is being backed up in the HOLD mode, the H level output at any ports is not sustained and is unpredictable.

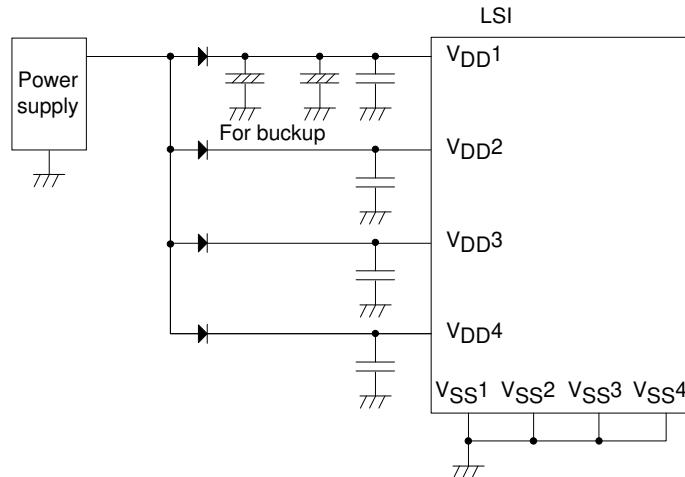

LC88F52H0A

Absolute Maximum Ratings at Ta = 25°C, VSS1 = VSS2 = VSS3 = VSS4 = 0V

Parameter	Symbol	Applicable Pin /Remarks	Conditions	Specification				unit
				VDD[V]	min	typ	max	
Maximum supply voltage	VDD max	VDD1, VDD2, VDD3, VDD4	VDD1=VDD2=VDD3=VDD4		-0.3		+6.5	V
Input voltage	VI(1)	RESB			-0.3		VDD +0.3	
Input/output voltage	VI/O(1)	Ports 0, 1, 2 Ports 3, 4, 5 Ports 6, 7 Ports A, B, C, D			-0.3		VDD +0.3	
High level output current	Peak output current	IOPH(1)	Ports 0, 1, 2, 3 P40 to P45 Ports 7, A, D PB2 to PB6	CMOS output selected Per applicable pin		-10		mA
		IOPH(2)	P46, P47 PB0, PB1	Per applicable pin		-20		
		IOPH(3)	Port 5, 6 PC0 to PC4	Per applicable pin		-5		
	Average output current (Note 1-1)	IOMH(1)	Ports 0, 1, 2, 3 P40 to P45 Ports 5, 6, 7, A PB2 to PB6 Ports D	CMOS output selected Per applicable pin		-7.5		
		IOMH(2)	P46, P47 PB0, PB1	Per applicable pin		-10		
		IOMH(3)	Port 5, 6 PC0 to PC4	Per applicable pin		-3		
	Total output current	ΣIOAH(1)	Pppts 5 PC0 to PC4	Total of currents at applicable pins		-15		
		ΣIOAH(2)	Port 6	Total of currents at applicable pins		-15		
		ΣIOAH(3)	Port 5, 6 PC0 to PC4	Total of currents at applicable pins		-20		
		ΣIOAH(4)	Ports 1,D1 P20 to P21	Total of currents at applicable pins		-25		
		ΣIOAH(5)	P22 to P27	Total of currents at applicable pins		-25		
		ΣIOAH(6)	Ports 1, 2, D	Total of currents at applicable pins		-45		
		ΣIOAH(7)	Ports 4	Total of currents at applicable pins		-25		
		ΣIOAH(8)	Ports 0, 3	Total of currents at applicable pins		-25		
		ΣIOAH(9)	Ports 0, 3, 4	Total of currents at applicable pins		-45		
ΣIOAH(10)		Ports B, 7	Total of currents at applicable pins		-25			
ΣIOAH(11)		Ports A	Total of currents at applicable pins		-25			
ΣIOAH(12)		Ports 7, A, B	Total of currents at applicable pins		-45			

Note 1-1: Average output current refers to the average of output currents measured for a period of 100ms.

Continued on next page.

LC88F52H0A

Continued from preceding page.

Parameter	Symbol	Applicable Pin /Remarks	Conditions	Specification				
				V _{DD} [V]	min	typ	max	unit
Low level output current	Peak output current	IOPL(1)	Ports 0, 1, 3, 4 Ports 7, A, B P20, P21, P24 to P27 PA0 to PA4, PA6, PA7 PB0 to PB4, PB6, PB7	Per applicable pin			20	mA
		IOPL(2)	P22, P23 PA4, PA5 PB4, PB5	Per applicable pin			25	
		IOPL(3)	Ports 5, 6 PC0 to PC4	Per applicable pin			10	
	Average output current (Note 1-1)	IOML(1)	Ports 0, 1, 3, 4 Ports 7, A, B P20, P21, P24 to P27 PA0 to PA4, PA6, PA7 PB0 to PB4, PB6, PB7	Per applicable pin			15	
		IOML(2)	P22, P23 PA4, PA5 PB4, PB5	Per applicable pin			20	
		IOML(3)	Ports 5, 6 PC0 to PC4	Per applicable pin			7.5	
	Total output current	ΣIOAL(1)	Ports 5 PC0 to PC2	Total of currents at applicable pins			15	
		ΣIOAL(2)	Port 6 PC3 to PC4	Total of currents at applicable pins			15	
		ΣIOAL(3)	Port 5, 6 PC0 to PC4	Total of currents at applicable pins			20	
		ΣIOAL(4)	Ports 1, D P20, P21	Total of currents at applicable pins			45	
		ΣIOAL(5)	P22 to P27	Total of currents at applicable pins			45	
		ΣIOAL(6)	Ports 1, 2, D	Total of currents at applicable pins			80	
ΣIOAL(7)		Port 4	Total of currents at applicable pins			45		
ΣIOAL(8)		Port 0, 3	Total of currents at applicable pins			45		
ΣIOAL(9)		Port 0, 3, 4	Total of currents at applicable pins			80		
ΣIOAL(10)		Port 7, B	Total of currents at applicable pins			45		
ΣIOAL(11)		Port A	Total of currents at applicable pins			45		
ΣIOAL(12)		Port 7, A, B	Total of currents at applicable pins			80		
Allowable power dissipation	Pd max	TQFP100(14×14)	Ta=-40 to +85°C			250	mW	
Operating ambient temperature	Topr				-40	+85	°C	
Storage ambient temperature	Tstg				-55	+125		

Note 1-1: Average output current refers to the average of output currents measured for a period of 100ms.

LC88F52H0A

Allowable Operating Conditions at Ta = -40°C to +85°C, VSS1 = VSS2 = VSS3 = VSS4 = 0V

Parameter	Symbol	Applicable Pin/Remarks	Conditions	Specification				unit
				VDD[V]	min	typ	max	
Operating supply voltage (Note 2-1)	VDD(1)	VDD1=VDD2=VDD3	0.081μs≤tCYC≤66μs		4.0		5.5	V
			0.103μs≤tCYC≤66μs		3.0		5.5	
			0.490μs≤tCYC≤66μs		2.5		5.5	
Memory sustaining supply voltage	VHD	VDD1=VDD2=VDD3	RAM and register contents sustained in HOLD mode		2.0		5.5	
High level input voltage	VIH(1)	Ports 0, 1, 2, 3, 4 Port 5, A, B		2.5 to 5.5	0.3VDD +0.7		VDD	
	VIH(2)	Ports 6, 7, PC2		2.5 to 5.5	0.3VDD +0.7		VDD	
	VIH(3)	RESB PC0, PC1, PC3, PC4		2.5 to 5.5	0.75VDD		VDD	
	VIH(4)	P22, P23, PA4, PA5, PB4, PB5 I ² C side		2.5 to 5.5	0.7VDD		VDD	
Low level input voltage	VIL(1)	When ports 1, 2, 3, 4, 5, A and port B, PnFSA _n =0		4.0 to 5.5	VSS		0.1VDD +0.4	
	VIL(2)	Ports 0, 6, 7, PC2		2.5 to 4.0	VSS		0.2VDD	
	VIL(3)	When ports 1, 2, 3, 4, 5, A and port B, PnFSA _n =1		4.0 to 5.5	VSS		0.15VDD +0.4	
	VIL(4)			2.5 to 4.0	VSS		0.2VDD	
	VIL(5)	CF1, RESB PC0, PC1, PC3, PC4		2.5 to 5.5	VSS		0.25VDD	
	VIL(6)	P22, P23, PA4, PA5, PB4, PB5 I ² C side		2.5 to 5.5	VSS		0.3VDD	
Instruction cycle time (Note 2-2)	tCYC			4.5 to 5.5	0.081		66	μs
				2.8 to 5.5	0.122		66	
				2.5 to 5.5	0.490		66	
External system clock frequency	FEXCF(1)	CF1	<ul style="list-style-type: none"> • CF2 pin open • System clock frequency division ratio=1/1 • External system clock DUTY50±5% 	4.5 to 5.5	0.1		12	MHz
				3.0 to 5.5	0.1		8.3	
				2.5 to 5.5	0.1		2	
				4.5 to 5.5	0.2		24	
				3.0 to 5.5	0.2		18.6	
				2.5 to 5.5	0.2		4	

Note 2-1: VDD≥3.0V must be maintained when making onboard programming into flash ROM.

Note 2-2: Relationship between tCYC and oscillation frequency is 1/FmCF when frequency division ratio is 1/1 and 2/FmCF when the ratio is 1/2.

Continued on next page.

LC88F52H0A

Continued from preceding page

Parameter	Symbol	Applicable Pin /Remarks	Conditions	Specification				
				VDD[V]	min	typ	max	unit
Oscillation frequency range (Note 2-3)	FmCF(1)	PC3 (CF1), PC4 (CF2)	12MHz ceramic oscillator mode See Fig. 1.	4.5 to 5.5		12		MHz
	FmCF(2)	PC3(CF1), PC4(CF2)	8MHz ceramic oscillator mode See Fig. 1.	3.0 to 5.5		8		
	FmCF(3)	PC3(CF1), PC4(CF2)	4MHz ceramic oscillator mode See Fig. 1.	2.5 to 5.5		4		
	FmRC		Internal RC oscillation	2.5 to 5.5	0.5	1.0	2.0	
	FmSLRC		Internal low-speed RC oscillation	2.5 to 5.5	18	30	45	
	FsX'tal	XT1, XT2	32.768kHz crystal oscillator mode See Fig. 2.	2.5 to 5.5		32.768		kHz
	FmVCO(1)		VCO oscillator When setting VC3=1 When SELDIV=0 or 1 See Fig. 9.	2.5 to 3.8	5.0		9.0	MHz
	FmVCO(2)		VCO oscillator When setting VC3=0 When SELDIV=2 or 3 See Fig. 9.	2.5 to 3.8	5.0		12	
	FmVCO(3)		VCO oscillator When setting VC3=1 When SELDIV=0 or 1 See Fig. 9.	3.6 to 5.5	5.0		9.0	
	FmVCO(4)		VCO oscillator When setting VC3=0 When SELDIV=2 or 3 See Fig. 9.	3.6 to 5.5	9.0		12	
	FmVCO(5)		VCO oscillator When OSC0=32.768KHz SELDIV setting range=0 to 3 SELDLY setting range=0 to 3	2.5 to 5.5		Note 2-4		

Note 2-3: See Tables 1 and 2 for oscillator constant values.

Note 2-4: VCO oscillation frequency = $0.032768 \times (56 \times (\text{SELDIV} + 3) + \text{SELDLY})$

LC88F52H0A

Electrical Characteristics at Ta = -40 to +85°C, VSS1 = VSS2 = VSS3 = VSS4 = 0V

Parameter	Symbol	Applicable/ Remarks	Conditions	Specification				
				V _{DD} [V]	min	typ	max	unit
High level input current	I _{IH} (1)	Ports 0, 1, 2 Ports 3, 4, 5 Ports 6, 7 Ports A, B, C, D RESB	Output disabled Pull-up resistor off V _{IN} =V _{DD} (Including output Tr. off leakage current)	2.5 to 5.5			1	μA
Low level input current	I _{IL} (1)	Ports 0, 1, 2 Ports 3, 4, 5 Ports 6, 7 Ports A, B, C, D RESB	Output disabled Pull-up resistor off V _{IN} =V _{SS} (Including output Tr. off leakage current)	2.5 to 5.5		-1		
High level output voltage	V _{OH} (1)	Ports 0, 1, 2, 3	I _{OH} =-1.0mA	4.5 to 5.5	V _{DD} -1			V
	V _{OH} (2)	Ports 4, A, D P40 to P45	I _{OH} =-0.4mA	3.0 to 5.5	V _{DD} -0.4			
	V _{OH} (3)	PB2 to PB6	I _{OH} =-0.2mA	2.5 to 5.5	V _{DD} -0.4			
	V _{OH} (4)	Port 5, 6	I _{OH} =-0.4mA	3.0 to 5.5	V _{DD} -0.4			
	V _{OH} (5)	PC2	I _{OH} =-0.2mA	2.5 to 5.5	V _{DD} -0.4			
	V _{OH} (6)	P46, P47	I _{OH} =-10mA	4.5 to 5.5	V _{DD} -1.5			
	V _{OH} (7)	PB0, PB1	I _{OH} =-1.6mA	3.0 to 5.5	V _{DD} -0.4			
	V _{OH} (8)		I _{OH} =-1.0mA	2.5 to 5.5	V _{DD} -0.4			
	V _{OH} (9)	PC0, PC1,	I _{OH} =-1.0mA	3.0 to 5.5	V _{DD} -0.4			
	V _{OH} (10)	PC3, PC4,	I _{OH} =-0.4mA	2.5 to 5.5	V _{DD} -0.4			
Low level output voltage	V _{OL} (1)	Ports 0, 1, 3, 4 Ports 7, D	I _{OL} =10mA	4.5 to 5.5			1.5	V
	V _{OL} (2)	P20 to P21, P24 to P27	I _{OL} =1.6mA	3.0 to 5.5			0.4	
	V _{OL} (3)	PA0 to PA3 PA6 to PA7 PB0 to PB3, PB6	I _{OL} =1.0mA	2.5 to 5.5			0.4	
	V _{OL} (4)	P22, P23,	I _{OL} =11mA	4.5 to 5.5			1.5	
	V _{OL} (5)	PA4, PA5,	I _{OL} =3.0mA	3.0 to 5.5			0.4	
	V _{OL} (6)	PB4, PB5	I _{OL} =1.3mA	2.5 to 5.5			0.4	
	V _{OL} (7)	Ports 5, 6	I _{OL} =1.6mA	3.0 to 5.5			0.4	
	V _{OL} (8)	PC2	I _{OL} =1.0mA	2.5 to 5.5			0.4	
	V _{OL} (9)	PC0, PC1,	I _{OL} =1.0mA	3.0 to 5.5			0.4	
	V _{OL} (10)	PC3, PC4	I _{OL} =0.4mA	2.5 to 5.5			0.4	
Pull-up resistor	R _{pU} (1)	Ports 0, 1, 2, 3 Ports 4, 5, 6, 7	V _{OH} =0.9V _{DD}	4.5 to 5.5	15	35	80	kΩ
	R _{pU} (2)	Ports A, B, D, PC2		2.5 to 4.5	18	55	150	
Hysteresis voltage	V _{HYS}	RESB When ports 1, 2, 3, 4, A PnFSA _n =1		2.5 to 5.5		0.1V _{DD}		V
Pin capacitance	CP	All pins	Pins other than that under test V _{IN} =V _{SS} f=1MHz Ta=25°C	2.5 to 5.5		10		pF

LC88F52H0A

Serial I/O Characteristics at Ta = -40 to +85°C, V_{SS1} = V_{SS2} = V_{SS3} = V_{SS4} = 0V

Serial I/O Characteristics (Wakeup Function Disabled) (Note 4-1-1)

Parameter		Symbol	Applicable Pin/Remarks	Conditions	V _{DD} [V]	Specification				
						min	typ	max	unit	
Serial clock	Input clock	Period	tSCK(1)	SCK0(P12)	• See Fig. 6.	2.5 to 5.5	4			tCYC
		Low level pulse width	tSCKL(1)				2			
		High level pulse width	tSCKH(1)				2			
			tSCKHA(1)				6			
		tSCKHBSY(1a)	23							
		tSCKHBSY(1b)	4							
	Output clock	Period	tSCK(2)	SCK0(P12)	• CMOS output selected • See Fig. 6.	2.5 to 5.5	4			tSCK
		Low level pulse width	tSCKL(2)				1/2			
		High level pulse width	tSCKH(2)				1/2			
			tSCKHA(2)				6			tCYC
		tSCKHBSY(2a)	4					23		
		tSCKHBSY(2b)	4							
Serial input	Data setup time	tsDI(1)	SI0(P11), SB0(P11)	• Specified with respect to rising edge of SIOCLK • See Fig. 6.	2.5 to 5.5	0.03				
	Data hold time	thDI(1)				0.03				
Serial output	Output delay time	tdD0(1)	SO0(P10), SB0(P11)	• (Note 4-1-2)	2.5 to 5.5			1tCYC +0.05	μs	
		tdD0(2)						1tCYC +0.05		

Note 4-1-1: These specifications are theoretical values. Add margin depending on its use.

Note 4-1-2: Specified with respect to the falling edge of SIOCLK. Specified as the interval up to the time an output change begins in the open drain output mode. See Fig. 6.

LC88F52H0A

SIO0 Serial Input/Output Characteristics (Wakeup Function Enabled) (Note 4-2-1)

Parameter		Symbol	Applicable Pin/Remarks	Conditions	V _{DD} [V]	Specification				
						min	typ	max	unit	
Serial clock	Input clock	Period	tSCK(3)	SCK0 (P12)	• See Fig. 6.	2.5 to 5.5	2			tCYC
		Low level pulse width	tSCKL(3)				1			
		High level pulse width	tSCKH(3)				1			
			tSCKHBSY(3)				2			
Serial input		Data setup time	tsDI(2)	SI0 (P11), SB0 (P11)	• Specified with respect to rising edge of SIOCLK • See Fig. 6.	2.5 to 5.5	0.03			μs
		Data hold time	thDI(2)				0.03			
Serial output	Input clock	Output delay time	tdD0(3)	SO0 (P10), SB0 (P11)	• (Note 4-2-2)	2.5 to 5.5			1tCYC +0.05	

Note 4-2-1: These specifications are theoretical values. Add margin depending on its use.

Note 4-2-2: Specified with respect to the falling edge of SIOCLK. Specified as the interval up to the time an output change begins in the open drain output mode. See Fig.6.

LC88F52H0A

SIO1 Serial Input/Output Characteristics (Wakeup Function Disabled) (Note 4-3-1)

Parameter		Symbol	Applicable Pin/Remarks	Conditions	V _{DD} [V]	Specification						
						min	typ	max	unit			
Serial clock	Input clock	Period	tSCK(4)	SCK1(P45)	• See Fig. 6.	2.5 to 5.5	4			tCYC		
		Low level pulse width	tSCKL(4)				2					
		High level pulse width	tSCKH(4)				2					
			tSCKHA(4)									
		tSCKHBSY(4a)							6			
		tSCKHBSY(4b)							23			
	Output clock	Period	tSCK(5)	SCK1(P45)	• CMOS output selected • See Fig. 6.	2.5 to 5.5	4			tCYC		
		Low level pulse width	tSCKL(5)				1/2		tSCK			
		High level pulse width	tSCKH(5)				1/2					
			tSCKHA(5)						6			
		tSCKHBSY(5a)							4			23
		tSCKHBSY(5b)							4			
Serial input	Data setup time	tsDI(3)	SI1(P44), SB1(P44)	• Specified with respect to rising edge of SIOCLK • See Fig. 6.	2.5 to 5.5	0.03			μs			
	Data hold time	thDI(3)				0.03						
Serial output	Output delay time	tdD0(4)	SO1(P43), SB1(P44)	• (Note 4-3-2)	2.5 to 5.5			1tCYC +0.05	μs			
		tdD0(5)		• (Note 4-3-2)				1tCYC +0.05				

Note 4-3-1: These specifications are theoretical values. Add margin depending on its use.

Note 4-3-2: Specified with respect to the falling edge of SIOCLK. Specified as the interval up to the time an output change begins in the open drain output mode. See Fig. 6.

LC88F52H0A

SIO1 Serial Input/Output Characteristics (Wakeup Function Enabled) (Note 4-4-1)

Parameter		Symbol	Applicable Pin/Remarks	Conditions	V _{DD} [V]	Specification				
						min	typ	max	unit	
Serial clock	Input clock	Period	tSCK(6)	SCK1(P45)	• See Fig. 6.	2.5 to 5.5	2			tCYC
		Low level pulse width	tSCKL(6)				1			
		High level pulse width	tSCKH(6)				1			
			tSCKHBSY(6)				2			
Serial input	Data setup time	tsDI(4)	SI1(P44), SB1(P44)	• Specified with respect to rising edge of SIOCLK • See Fig. 6.	2.5 to 5.5	0.03			μs	
	Data hold time	thDI(4)				0.03				
Serial output	Input clock	Output delay time	tdD0(6)	SO1(P43), SB1(P44)	• (Note 4-4-2)	2.5 to 5.5			1tCYC +0.05	

Note 4-4-1: These specifications are theoretical values. Add margin depending on its use.

Note 4-4-2: Specified with respect to the falling edge of SIOCLK. Specified as the interval up to the time an output change begins in the open drain output mode. See Fig. 6.

SMIIC0 Simple SIO Mode Input/Output Characteristics

Parameter		Symbol	Applicable Pin/Remarks	Conditions	V _{DD} [V]	Specification				
						min	typ	max	unit	
Serial clock	Input clock	Period	tSCK(7)	SM0CK(P22)	See Fig. 6.	2.5 to 5.5	4			tCYC
		Low level pulse width	tSCKL(7)				2			
		High level pulse width	tSCKH(7)				2			
	Output clock	Period	tSCK(8)	SM0CK(P22)	• CMOS output selected • See Fig. 6.	2.5 to 5.5	4			tSCK
		Low level pulse width	tSCKL(8)				1/2			
		High level pulse width	tSCKH(8)				1/2			
Serial input	Data setup time	tsDI(5)	SM0DA(P23)	• Specified with respect to rising edge of SIOCLK • See Fig. 6.	2.5 to 5.5	0.03			μs	
	Data hold time	thDI(5)				0.03				
Serial output	Output delay time	tdD0(7)	SM0DO(P24), SM0DA(P23)	• Specified with respect to falling edge of SIOCLK • Specified as interval up to time when output state starts changing. • See Fig. 6.	2.5 to 5.5			1tCYC +0.05		

Note 4-5-1: These specifications are theoretical values. Add margin depending on its use.

LC88F52H0A

SMIIC0 I²C Mode Input/Output Characteristics

Parameter		Symbol	Applicable Pin/Remarks	Conditions	V _{DD} [V]	Specification				
						min	typ	max	unit	
Clock	Input clock	Period	tSCL	SM0CK(P22)	• See Fig. 8.	2.5 to 5.5	5			Tfilt
		Low level pulse width	tSCLL				2.5			
		High level pulse width	tSCLH				2			
	Output clock	Period	tSCLx	SM0CK(P22)	• Specified as interval up to time when output state starts changing.	2.5 to 5.5	10			tSCL
		Low level pulse width	tSCLLx				1/2			
		High level pulse width	tSCLHx				1/2			
SM0CK and SM0DA pins input spike suppression time		tsp	SM0CK(P22) SM0DA(P23)	• See Fig. 8.	2.5 to 5.5			1	Tfilt	
Bus release time between start and stop	Input	tBUF	SM0CK(P22) SM0DA(P23)	• See Fig. 8.	2.5 to 5.5	2.5			Tfilt	
	Output	tBUFx	SM0CK(P22) SM0DA(P23)	<ul style="list-style-type: none"> • Standard clock mode • Specified as interval up to time when output state starts changing. • High-speed clock mode • Specified as interval up to time when output state starts changing. 		5.5			μs	
Start/restart condition hold time	Input	tHD;STA	SM0CK(P22) SM0DA(P23)	<ul style="list-style-type: none"> • When SMIIC register control bit, I²CSHDS=0 • See Fig. 8. 	2.5 to 5.5	2.0			Tfilt	
				<ul style="list-style-type: none"> • When SMIIC register control bit, I²CSHDS=1 • See Fig. 8. 		2.5				
	Output	tHD;STAx	SM0CK(P22) SM0DA(P23)	<ul style="list-style-type: none"> • Standard clock mode • Specified as interval up to time when output state starts changing. 	4.1			μs		
				<ul style="list-style-type: none"> • High-speed clock mode • Specified as interval up to time when output state starts changing. 	1.0					
Restart condition setup time	Input	tSU;STA	SM0CK(P22) SM0DA(P23)	• See Fig. 8.	2.5 to 5.5	1.0			Tfilt	
	Output	tSU;STAx	SM0CK(P22) SM0DA(P23)	<ul style="list-style-type: none"> • Standard clock mode • Specified as interval up to time when output state starts changing. • High-speed clock mode • Specified as interval up to time when output state starts changing. 		5.5			μs	

Continued on next page.

LC88F52H0A

Continued from preceding page

Parameter	Symbol	Applicable Pin/Remarks	Conditions	V _{DD} [V]	Specification				
					min	typ	max	unit	
Stop condition setup time	Input	tSU;STO	SM0CK(P22) SM0DA(P23)	• See Fig. 8.	2.5 to 5.5	1.0			Tfilt
	Output	tSU;STOx	SM0CK(P22) SM0DA(P23)	<ul style="list-style-type: none"> • Standard clock mode • Specified as interval up to time when output state starts changing. • High-speed clock mode • Specified as interval up to time when output state starts changing. 		4.9			μs
						1.1			
Data hold time	Input	tHD;DAT	SM0CK(P22) SM0DA(P23)	• See Fig. 8.	2.5 to 5.5	0			Tfilt
	Output	tHD;DATx	SM0CK(P22) SM0DA(P23)	• Specified as interval up to time when output state starts changing.		1		1.5	
Data setup time	Input	tSU;DAT	SM0CK(P22) SM0DA(P23)	• See Fig. 8.	2.5 to 5.5	1			Tfilt
	Output	tSU;DATx	SM0CK(P22) SM0DA(P23)	• Specified as interval up to time when output state starts changing.		tSCL -1.5Tfilt			
SM0CK and SM0DA pins fall time	Input	tF	SM0CK(P22) SM0DA(P23)	• See Fig. 8.	2.5 to 5.5			300	ns
	Output	tF	SM0CK (P22) SM0DA (P23)	<ul style="list-style-type: none"> • When SMIIC register control bits, PSLW=1, P5V=1 • When SMIIC register control bits, PSLW=1, P5V=0 • SM0CK, SM0DA port output FAST mode • Cb≤400pF 	5	20 +0.1Cb	250		
					3	20 +0.1Cb	250		
					3 to 5.5		100		

Note 4-6-1: These specifications are theoretical values. Add margin depending on its use.

Note 4-6-2: The value of Tfilt is determined by the values of the register SMIC0BRG, bits 7 and 6 (BRP1, BRP0) and the system clock frequency.

BRP1	BRP0	Tfilt
0	0	tCYC×1
0	1	tCYC×2
1	0	tCYC×3
1	1	tCYC×4

Set bits (BRP1, BRP0) so that the value of Tfilt falls between the following range:
 $250\text{ns} \geq \text{Tfilt} > 140\text{ns}$

Note 4-6-3: Cb represents the total loads (in pF) connected to the bus pins. $C_b \leq 400\text{pF}$

Note 4-6-4: The standard clock mode refers to a mode that is entered by configuring SMIC0BRG as follows:

$250\text{ns} \geq \text{Tfilt} > 140\text{ns}$
 BRDQ (bit5) = 1
 SCL frequency setting $\leq 100\text{kHz}$

The high-speed clock mode refers to a mode that is entered by configuring SMIC0BRG as follows:

$250\text{ns} \geq \text{Tfilt} > 140\text{ns}$
 BRDQ (bit5) = 0
 SCL frequency setting $\leq 400\text{kHz}$

LC88F52H0A

SMIIC1 Simple SIO Mode Input/Output Characteristics

Parameter		Symbol	Applicable Pin/Remarks	Conditions	V _{DD} [V]	Specification				
						min	typ	max	unit	
Serial clock	Input clock	Period	tSCK(7)	SM1CK(PB4)	See Fig. 6.	2.5 to 5.5	4			tCYC
		Low level pulse width	tSCKL(7)				2			
		High level pulse width	tSCKH(7)				2			
	Output clock	Period	tSCK(8)	SM1CK(PB4)	<ul style="list-style-type: none"> • CMOS output selected • See Fig. 6. 	2.5 to 5.5	4			tSCK
		Low level pulse width	tSCKL(8)				1/2			
		High level pulse width	tSCKH(8)				1/2			
Serial input	Data setup time	tsDI(5)	SM1DA(PB5)	<ul style="list-style-type: none"> • Specified with respect to rising edge of SIOCLK • See Fig. 6. 	2.5 to 5.5	0.03			μs	
	Data hold time	thDI(5)				0.03				
Serial output	Output delay time	tdD0(7)	SM1DO(PB6), SM1DA(PB5)	<ul style="list-style-type: none"> • Specified with respect to falling edge of SIOCLK • Specified as interval up to time when output state starts changing. • See Fig. 6. 	2.5 to 5.5			1tCYC +0.05		

Note 4-7-1: These specifications are theoretical values. Add margin depending on its use.

LC88F52H0A

SMIIC1 I²C Mode Input/Output Characteristics

Parameter		Symbol	Applicable Pin/Remarks	Conditions	V _{DD} [V]	Specification				
						min	typ	max	unit	
Clock	Input clock	Period	tSCL	SM1CK(PB4)	• See Fig. 8.	2.5 to 5.5	5			Tfilt
		Low level pulse width	tSCLL				2.5			
		High level pulse width	tSCLH				2			
	Output clock	Period	tSCLx	SM1CK(PB4)	• Specified as interval up to time when output state starts changing.	2.5 to 5.5	10			tSCL
		Low level pulse width	tSCLLx				1/2			
		High level pulse width	tSCLHx				1/2			
SM0CK and SM0DA pins input spike suppression time		tsp	SM1CK(PB4) SM1DA(PB5)	• See Fig. 8.	2.5 to 5.5			1	Tfilt	
Bus release time between start and stop	Input	tBUF	SM1CK(PB4) SM1DA(PB5)	• See Fig. 8.	2.5 to 5.5	2.5			Tfilt	
	Output	tBUFx	SM1CK(PB4) SM1DA(PB5)	<ul style="list-style-type: none"> • Standard clock mode • Specified as interval up to time when output state starts changing. • High-speed clock mode • Specified as interval up to time when output state starts changing. 		5.5			μs	
Start/restart condition hold time	Input	tHD;STA	SM1CK(PB4) SM1DA(PB5)	<ul style="list-style-type: none"> • When SMIIC register control bit, I²CSHDS=0 • See Fig. 8. 	2.5 to 5.5	2.0			Tfilt	
				<ul style="list-style-type: none"> • When SMIIC register control bit, I²CSHDS=1 • See Fig. 8. 		2.5				
	Output	tHD;STAx	SM1CK(PB4) SM1DA(PB5)	<ul style="list-style-type: none"> • Standard clock mode • Specified as interval up to time when output state starts changing. 	4.1			μs		
				<ul style="list-style-type: none"> • High-speed clock mode • Specified as interval up to time when output state starts changing. 	1.0					
Restart condition setup time	Input	tSU;STA	SM1CK(PB4) SM1DA(PB5)	• See Fig. 8.	2.5 to 5.5	1.0			Tfilt	
	Output	tSU;STAx	SM1CK(PB4) SM1DA(PB5)	<ul style="list-style-type: none"> • Standard clock mode • Specified as interval up to time when output state starts changing. • High-speed clock mode • Specified as interval up to time when output state starts changing. 		5.5			μs	

Continued on next page.

LC88F52H0A

Continued from preceding page

Parameter	Symbol	Applicable Pin/Remarks	Conditions	V _{DD} [V]	Specification				
					min	typ	max	unit	
Stop condition setup time	Input	tSU;STO	SM1CK(PB4) SM1DA(PB5)	• See Fig. 8.	2.5 to 5.5	1.0			Tfilt
	Output	tSU;STOx	SM1CK(PB4) SM1DA(PB5)	<ul style="list-style-type: none"> • Standard clock mode • Specified as interval up to time when output state starts changing. • High-speed clock mode • Specified as interval up to time when output state starts changing. 		4.9			μs
Data hold time	Input	tHD;DAT	SM1CK(PB4) SM1DA(PB5)	• See Fig. 8.	2.5 to 5.5	0			Tfilt
	Output	tHD;DATx	SM1CK(PB4) SM1DA(PB5)	• Specified as interval up to time when output state starts changing.		1		1.5	
Data setup time	Input	tSU;DAT	SM1CK(PB4) SM1DA(PB5)	• See Fig. 8.	2.5 to 5.5	1			Tfilt
	Output	tSU;DATx	SM1CK(PB4) SM1DA(PB5)	• Specified as interval up to time when output state starts changing.		tSCL -1.5Tfilt			
SM0CK and SM0DA pins fall time	Input	tF	SM1CK(PB4) SM1DA(PB5)	• See Fig. 8.	2.5 to 5.5			300	ns
	Output	tF	SM1CK(PB4) SM1DA(PB5)	• When SMIIC register control bits PSLW=1, P5V=1	5	20 +0.1Cb	250		
				• When SMIIC register control bits PSLW=1, P5V=0	3	20 +0.1Cb	250		
			• SM0CK, SM0DA port output FAST mode • Cb≤400pF	3 to 5.5			100		

Note 4-8-1: These specifications are theoretical values. Add margin depending on its use.

Note 4-8-2: The value of Tfilt is determined by the values of the register SMIC1BRG, bits 7 and 6 (BRP1, BRP0) and the system clock frequency.

BRP1	BRP0	Tfilt
0	0	tCYC×1
0	1	tCYC×2
1	0	tCYC×3
1	1	tCYC×4

Set bits (BPR1, BPR0) so that the value of Tfilt falls between the following range:

$$250\text{ns} \geq T_{\text{filt}} > 140\text{ns}$$

Note 4-8-3: Cb represents the total loads (in pF) connected to the bus pins. Cb ≤ 400pF

Note 4-8-4: The standard clock mode refers to a mode that is entered by configuring SMIC1BRG as follows:

$$250\text{ns} \geq T_{\text{filt}} > 140\text{ns}$$

$$\text{BRDQ (bit5)} = 1$$

SCL frequency setting ≤ 100kHz

The high-speed clock mode refers to a mode that is entered by configuring SMIC1BRG as follows:

$$250\text{ns} \geq T_{\text{filt}} > 140\text{ns}$$

$$\text{BRDQ (bit5)} = 0$$

SCL frequency setting ≤ 400kHz

LC88F52H0A

SLIIC0 Simple SIO Mode Input/Output Characteristics

Parameter		Symbol	Applicable Pin/Remarks	Conditions	V _{DD} [V]	Specification				
						min	typ	max	unit	
Serial clock	Input clock	Period	tSCK(9)	SL0CK(PA4)	See Fig. 6.	2.5 to 5.5	4			tCYC
		Low level pulse width	tSCKL(9)				2			
		High level pulse width	tSCKH(9)				2			
Serial input	Data setup time	tsDI(7)	SL0DA(PA5)	<ul style="list-style-type: none"> • Specified with respect to rising edge of SIOCLK • See Fig. 6. 	2.5 to 5.5	0.03			μs	
	Data hold time	thDI(7)				0.03				
Serial output	Output delay time	tdD0(9)	SL0DO(PA6), SL0DA(PA5)	<ul style="list-style-type: none"> • Specified with respect to falling edge of SIOCLK • Specified as interval up to time when output state starts changing. • See Fig. 6. 	2.5 to 5.5			1tCYC +0.05		

Note 4-9-1: These specifications are theoretical values. Add margin depending on its use.

LC88F52H0A

SLIC1 I²C Mode Input/Output Characteristics

Parameter		Symbol	Applicable Pin/Remarks	Conditions	V _{DD} [V]	Specification				
						min	typ	max	unit	
Clock	Input clock	Period	tSCL	SL0CK(PA4)	• See Fig. 8.	2.5 to 5.5	5			Tfilt
		Low level pulse width	tSCLL	SL0DA(PA5)			2.5			
		High level pulse width	tSCLH				2			
SL0CK and SL0DA pins input spike suppression time		tsp	SL0CK(PA4) SL0DA(PA5)	• See Fig. 8.	2.5 to 5.5			1	Tfilt	
Bus release time between start and stop		tBUF	SL0CK(PA4) SL0DA(PA5)	• See Fig. 8.	2.5 to 5.5	2.5			Tfilt	
Start/restart condition hold time		tHD;STA	SL0CK(PA4) SL0DA(PA5)	• When SMIIC register control bit, I ² CSHDS=0	2.5 to 5.5	2.0			Tfilt	
				• When SMIIC register control bit I ² CSHDS=1		2.5				
Restart condition setup time		tSU;STA	SL0CK(PA4) SL0DA(PA5)	• See Fig. 8.	2.5 to 5.5	1.0			Tfilt	
Stop condition setup time		tSU;STO	SL0CK(PA4) SL0DA(PA5)	• See Fig. 8.	2.5 to 5.5	1.0			Tfilt	
Data hold time		tHD;DAT	SL0CK(PA4) SL0DA(PA5)	• See Fig. 8.	2.5 to 5.5	0			Tfilt	
						tHD;DATx	SL0CK(PA4) SL0DA(PA5)	• Specified as interval up to time when output state starts changing.		1
Data setup time		tSU;DAT	SL0CK(PA4) SL0DA(PA5)	• See Fig. 8.	2.5 to 5.5	1			Tfilt	
						tSU;DATx	SL0CK(PA4) SL0DA(PA5)	• Specified as interval up to time when output state starts changing.		1tSCL -1.5Tfilt

LC88F52H0A

UART0 Operating Conditions at Ta = -40 to +85°C, VSS1 = VSS2 = VSS3 = VSS4 = 0V

Parameter	Symbol	Applicable Pin/Remarks	Conditions	Specification				
				V _{DD} [V]	min	typ	max	unit
Transfer rate	UBR0	U0RX(P13), U0TX(P14), U0BRG(P07)		2.5 to 5.5	4		8	tBGCYC

Note 4-9: tBGCYC denotes one cycle of the baudrate clock source.

UART2 Operating Conditions at Ta = -40 to +85°C, VSS1 = VSS2 = VSS3 = VSS4 = 0V

Parameter	Symbol	Applicable Pin/Remarks	Conditions	Specification				
				V _{DD} [V]	min	typ	max	unit
Transfer rate	UBR2	U2RX(P16), U2TX(P17)		2.5 to 5.5	8		4096	tBGCYC

Note 4-10: tBGCYC denotes one cycle of the baudrate clock source.

UART3 Operating Conditions at Ta = -40 to +85°C, VSS1 = VSS2 = VSS3 = VSS4 = 0V

Parameter	Symbol	Applicable Pin/Remarks	Conditions	Specification				
				V _{DD} [V]	min	typ	max	unit
Transfer rate	UBR3	U3RX(P34), U3TX(P35)		2.5 to 5.5	8		4096	tBGCYC

Note 4-10: tBGCYC denotes one cycle of the baudrate clock source.

UART4 Operating Conditions at Ta = -40 to +85°C, VSS1 = VSS2 = VSS3 = VSS4 = 0V

Parameter	Symbol	Applicable Pin/Remarks	Conditions	Specification				
				V _{DD} [V]	min	typ	max	unit
Transfer rate	UBR4	U4RX(PB2), U4TX(PB3)		2.5 to 5.5	8		4096	tBGCYC

Note 4-10: tBGCYC denotes one cycle of the baudrate clock source.

Pulse Input Conditions at Ta = -40 to +85°C, VSS1 = VSS2 = VSS3 = VSS4 = 0V

Parameter	Symbol	Applicable Pin/Remarks	Conditions	Specification				
				V _{DD} [V]	min	typ	max	unit
High/low level pulse width	tPIH(1) tPIL(1)	INT0(P30), INT1(P31), INT2(P32), INT3(P33), INT4(P20), INT5(P21), INT6(P40), INT7(P41)	<ul style="list-style-type: none"> • Interrupt source flag can be set. • Event inputs for timers 2 and 3 are enabled. 	2.5 to 5.5	2			tCYC
	tPIL(2)	RESB	Resetting is enabled.	2.5 to 5.5	10			μs

LC88F52H0A

AD Converter Characteristics at Ta = -40 to +85°C, VSS1 = VSS2 = VSS3 = VSS4 = 0V

12-bit AD Conversion Mode

Parameter	Symbol	Applicable Pin /Remarks	Conditions	Specification				
				VDD[V]	min	typ	max	unit
Resolution	NAD	AN0(P60) to AN7(P67), AN8(P70) to AN15(P77)		3.0 to 5.5		12		bit
Absolute accuracy	ETAD		(Note 6-1)	3.0 to 5.5			±16	LSB
Conversion time	TCAD12		Conversion time calculated	4.5 to 5.5	27		209	μs
				3.0 to 5.5	67		209	
Analog input voltage range	VAIN			3.0 to 5.5	VSS		VDD	V
Analog port input current	IAINH		VAIN=VDD	3.0 to 5.5			1	μA
	IAINL	VAIN=VSS	3.0 to 5.5	-1				

Conversion time calculation formula: TCAD12= ((52/(AD division ratio))+2) × tCYC

8-bit AD Conversion Mode

Parameter	Symbol	Applicable Pin /Remarks	Conditions	Specification				
				VDD[V]	min	typ	max	unit
Resolution	NAD	AN0(P60) to AN7(P67), AN8(P70) to AN15(P77)		3.0 to 5.5		8		bit
Absolute accuracy	ETAD		(Note 6-1)	3.0 to 5.5			±1.5	LSB
Conversion time	TCAD8		Conversion time calculated	4.5 to 5.5	17		129	μs
				3.0 to 5.5	42		129	
Analog input voltage range	VAIN			3.0 to 5.5	VSS		VDD	V
Analog port input current	IAINH		VAIN=VDD	3.0 to 5.5			1	μA
	IAINL	VAIN=VSS	3.0 to 5.5	-1				

Conversion time calculation formula: TCAD8= ((32/(AD division ratio))+2) × tCYC

Note 6-1: The quantization error (±1/2LSB) is excluded from the absolute accuracy.

Note 6-2: The conversion time refers to the interval from the time a conversion starting instruction is issued till the time the complete digital value against the analog input value is loaded in the result register.

The conversion time is twice the normal value when one of the following conditions occurs:

- The first AD conversion is executed in the 12-bit AD conversion mode after a system reset.
- The first AD conversion is executed after the AD conversion mode is switched from 8-bit to 12-bit AD conversion mode.

DA Converter Characteristics

at Ta=-40 to+85°C, VSS1=VSS2=VSS3=VSS4=0V

Parameter	Symbol	Applicable Pin /Remarks	Conditions	Specification				
				VDD[V]	min	typ	max	unit
Resolution	NDA	DA00(PD0) to DA02(PD2), DA10(PD3) to DA12(PD5)		3.0 to 5.5		8		bit
Absolute accuracy	ETDA			3.0 to 5.5			±2.0	LSB
Output resistor	DAOR			3.0 to 5.5	9.5	16.0	22.9	kΩ
Analog port output current	VDAOUT			3.0 to 5.5	VSS		VDD	V

LC88F52H0A

Consumption Current Characteristics at Ta=-40 to +85°C, V_{SS1}=V_{SS2}=V_{SS3}=V_{SS4}=0V
 typ: 5.0V (V_{DD}=4.5V to 5.5V), 3.3V (V_{DD}=3.0V to 4.5V, 2.2V to 4.5V)

Parameter	Symbol	Applicable Pin/Remarks	Conditions	Specification				
				V _{DD} [V]	min	typ	max	unit
Normal mode consumption current (Note 7-1)	IDDOP(1)	V _{DD1} =V _{DD2} =V _{DD3} =V _{DD4}	<ul style="list-style-type: none"> • FmCF=12MHz ceramic oscillation mode • FmX'tal=32.768kHz crystal oscillation mode • System clock set to 12MHz • Internal RC oscillation stopped • 1/1 frequency division mode 	4.5 to 5.5		10.4	19	mA
	IDDOP(2)		<ul style="list-style-type: none"> • FmCF=8MHz ceramic oscillator mode • FmX'tal=32.768kHz crystal oscillator mode • System clock set to 8MHz • Internal RC oscillation stopped • 1/1 frequency division mode 	4.5 to 5.5		8.50	17	
	IDDOP(3)		<ul style="list-style-type: none"> • FmCF=4MHz ceramic oscillator mode • FmX'tal=32.768kHz crystal oscillator mode • System clock set to 4MHz • Internal RC oscillation stopped • 1/2 frequency division mode 	3.0 to 4.5		4.91	13	
	IDDOP(4)		<ul style="list-style-type: none"> • FmCF=0Hz (oscillation stopped) • FmX'tal=32.768kHz crystal oscillator mode • System clock set to internal RC oscillation • 1/1 frequency division mode 	4.5 to 5.5		4.02	6.1	
	IDDOP(5)		<ul style="list-style-type: none"> • FmCF=0Hz (oscillation stopped) • FmX'tal=32.768kHz crystal oscillator mode • System clock set to 32.768kHz • Internal RC oscillation stopped • 1/1 frequency division mode 	2.5 to 4.5		2.62	4.3	
	IDDOP(6)		<ul style="list-style-type: none"> • FmCF=0Hz (oscillation stopped) • FmX'tal=32.768kHz crystal oscillator mode • System clock set to 32.768kHz • Internal RC oscillation stopped • 1/1 frequency division mode 	4.5 to 5.5		2.18	6.0	
	IDDOP(7)		<ul style="list-style-type: none"> • FmCF=0Hz (oscillation stopped) • FmX'tal=32.768kHz crystal oscillator mode • System clock set to VCO • Internal RC oscillation stopped • 1/1 frequency division mode 	2.2 to 4.5		1.28	4.2	
	IDDOP(8)		<ul style="list-style-type: none"> • FmCF=0Hz (oscillation stopped) • FmVCO=11.1MHz oscillator mode • FmX'tal=32.768kHz crystal oscillator mode • System clock set to VCO • Internal RC oscillation stopped • 1/1 frequency division mode 	4.5 to 5.5		72.9	195	μA
	IDDOP(9)		<ul style="list-style-type: none"> • FmCF=0Hz (oscillation stopped) • FmVCO=7.34MHz oscillator mode • FmX'tal=32.768kHz crystal oscillator mode • System clock set to VCO • Internal RC oscillation stopped • 1/1 frequency division mode 	2.2 to 4.5		39.8	160	
	IDDOP(10)		<ul style="list-style-type: none"> • FmCF=0Hz (oscillation stopped) • FmVCO=7.34MHz oscillator mode • FmX'tal=32.768kHz crystal oscillator mode • System clock set to VCO • Internal RC oscillation stopped • 1/1 frequency division mode 	4.5 to 5.5		10.5	19.2	mA
	IDDOP(11)		<ul style="list-style-type: none"> • FmCF=0Hz (oscillation stopped) • FmVCO=7.34MHz oscillator mode • FmX'tal=32.768kHz crystal oscillator mode • System clock set to VCO • Internal RC oscillation stopped • 1/1 frequency division mode 	4.5 to 5.5		9.07	17.3	
	IDDOP(12)		<ul style="list-style-type: none"> • FmCF=0Hz (oscillation stopped) • FmVCO=7.34MHz oscillator mode • FmX'tal=32.768kHz crystal oscillator mode • System clock set to VCO • Internal RC oscillation stopped • 1/1 frequency division mode 	3.0 to 4.5		5.23	13.8	

Note 7-1: The consumption current value includes none of the currents that flow into the output transistor and internal pull-up resistors.

Continued on next page.

LC88F52H0A

Continued from preceding page.

Parameter	Symbol	Applicable Pin/Remarks	Conditions	Specification					
				V _{DD} [V]	min	typ	max	unit	
HALT mode consumption current (Note 7-1)	IDDHALT(1)	V _{DD1} =V _{DD2} =V _{DD3} =V _{DD4}	<ul style="list-style-type: none"> • HALT mode • FmCF=12MHz ceramic mode • FmX'tal=32.768kHz crystal oscillation mode • System clock set to 12MHz • Internal RC oscillation stopped • 1/1 frequency division mode 	4.5 to 5.5		3.70	6.5	mA	
	IDDHALT(2)		<ul style="list-style-type: none"> • HALT mode • FmCF=10MHz ceramic oscillator mode • FmX'tal=32.768kHz crystal oscillator mode • System clock set to 10MHz • Internal RC oscillation stopped • 1/1 frequency division mode 	4.5 to 5.5		2.60	5.0		
	IDDHALT(3)		<ul style="list-style-type: none"> • HALT mode • FmCF=10MHz ceramic oscillator mode • FmX'tal=32.768kHz crystal oscillator mode • System clock set to 10MHz • Internal RC oscillation stopped • 1/1 frequency division mode 	3.0 to 4.5		1.34	3.5		
	IDDHALT(4)		<ul style="list-style-type: none"> • HALT mode • FmCF=4MHz ceramic oscillator mode • FmX'tal=32.768kHz crystal oscillator mode • System clock set to 4MHz • Internal RC oscillation stopped • 1/2 frequency division mode 	4.5 to 5.5		1.08	3.1		
	IDDHALT(5)		<ul style="list-style-type: none"> • HALT mode • FmCF=4MHz ceramic oscillator mode • FmX'tal=32.768kHz crystal oscillator mode • System clock set to 4MHz • Internal RC oscillation stopped • 1/2 frequency division mode 	2.2 to 4.5		0.50	2.2		
	IDDHALT(6)		<ul style="list-style-type: none"> • HALT mode • FmCF=0Hz (oscillation stopped) • FmX'tal=32.768kHz crystal oscillator mode • System clock set to internal RC oscillation • 1/1 frequency division mode 	4.5 to 5.5		0.53	3.0		
	IDDHALT(7)		<ul style="list-style-type: none"> • HALT mode • FmCF=0Hz (oscillation stopped) • FmX'tal=32.768kHz crystal oscillator mode • System clock set to internal RC oscillation • 1/1 frequency division mode 	2.2 to 4.5		0.26	2.1		
	IDDHALT(8)		<ul style="list-style-type: none"> • HALT mode • FmCF=0Hz (oscillation stopped) • FmX'tal=32.768kHz crystal oscillator mode • System clock set to 32.768kHz • Internal RC oscillation stopped • 1/1 frequency division mode 	4.5 to 5.5		27.3	145	μA	
	IDDHALT(9)			2.2 to 4.5		9.52	112		
	IDDHALT(10)		<ul style="list-style-type: none"> • HALT mode • FmCF=0Hz (oscillation stopped) • FmVCO=11.1MHz oscillator mode • FmX'tal=32.768kHz crystal oscillator mode • System clock set to VCO • Internal RC oscillation stopped • 1/1 frequency division mode 	4.5 to 5.5		4.19	6.8	mA	
	IDDHALT(11)			<ul style="list-style-type: none"> • HALT mode • FmCF=0Hz (oscillation stopped) • FmVCO=7.34MHz oscillator mode • FmX'tal=32.768kHz crystal oscillator mode • System clock set to VCO • Internal RC oscillation stopped • 1/1 frequency division mode 	4.5 to 5.5		3.18		5.5
	IDDHALT(12)			<ul style="list-style-type: none"> • HALT mode • FmCF=0Hz (oscillation stopped) • FmVCO=7.34MHz oscillator mode • FmX'tal=32.768kHz crystal oscillator mode • System clock set to VCO • Internal RC oscillation stopped • 1/1 frequency division mode 	3.0 to 4.5		1.68		4.0
HOLD mode consumption current	IDDHOLD(1)	V _{DD1}	HOLD mode <ul style="list-style-type: none"> • CF1=V_{DD} or open (external clock mode) 	4.5 to 5.5		0.11	98	μA	
	IDDHOLD(2)			2.5 to 4.5		0.04	72		
HOLDX mode consumption current	IDDHOLD(3)		HOLDX mode <ul style="list-style-type: none"> • CF1=V_{DD} or open (external clock mode) • FmX'tal=32.768kHz crystal oscillator mode 	4.5 to 5.5		19.0	132		
	IDDHOLD(4)			2.5 to 4.5		4.91	90		

Note 7-1: The consumption current value includes none of the currents that flow into the output transistor and internal pull-up resistors.

LC88F52H0A

F-ROM Programming Characteristics at $T_a = +10^{\circ}\text{C}$ to $+55^{\circ}\text{C}$, $V_{SS1}=V_{SS2}=V_{SS3}=V_{SS4}=0\text{V}$

Parameter	Symbol	Applicable Pin/Remarks	Conditions	Specification				
				$V_{DD}[\text{V}]$	min	typ	max	unit
Onboard programming current	I _{DDFW} (1)	V _{DD1}	• Microcontroller erase current current is excluded.	3.0 to 5.5			15	mA
Onboard programming time	t _{FW} (1)		• 512-/1K-byte erase operation	3.0 to 5.5			30	ms
	t _{FW} (2)		• 2-byte programming operation	3.0 to 5.5			60	μs

Power Pin Treatment Conditions 1 (V_{DD1}, V_{SS1})

Connect capacitors that meet the following conditions between the V_{DD1} and V_{SS1} pins:

- Connect among the V_{DD1} and V_{SS1} pins and the capacitors C1 and C2 with the shortest possible lead wires, of the same length ($L_1=L_1'$, $L_2=L_2'$) wherever possible.
- Connect a large-capacity capacitor C1 and a small-capacity capacitor C2 in parallel. The capacitance of C2 should be approximately 0.1μF or larger.
- The V_{DD1} and V_{SS1} traces must be thicker than the other traces.

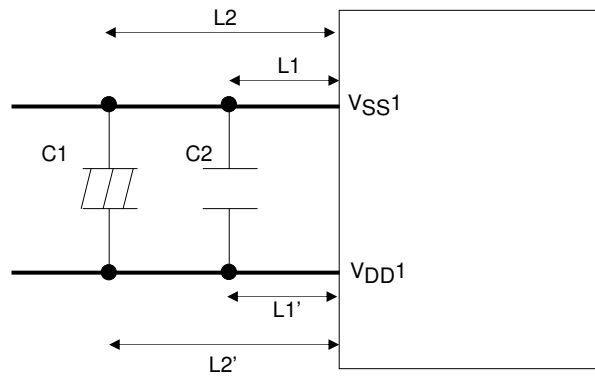

Power Pin Treatment Conditions 2 (V_{DD}(2, 3, 4), V_{SS}(2, 3, 4))

Connect capacitors that meet the following condition between the V_{DD}(2, 3, 4) and V_{SS}(2, 3, 4) pins:

- Connect among the V_{DD}(2, 3, 4) and V_{SS}(2, 3, 4) pins and the capacitor C3 with the shortest possible lead wires, of the same length ($L_3=L_3'$) wherever possible.
- The capacitance of C3 should be approximately 0.1μF or larger.
- The V_{DD}(2, 3, 4) and V_{SS}(2, 3, 4) traces must be thicker than the other traces.

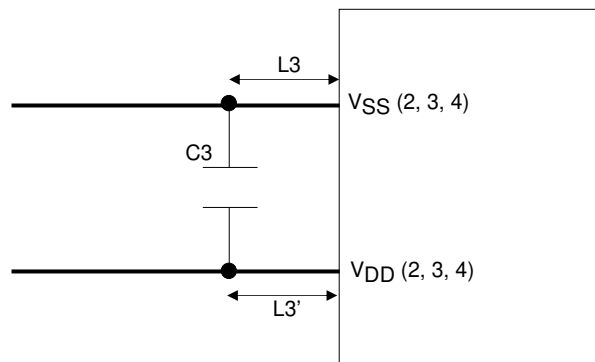

Characteristics of a Sample OSC1 System Clock Oscillation Circuit

Given below are the characteristics of a sample main system clock oscillation circuit that are measured using a SANYO-designated oscillation characteristics evaluation board and external components with circuit constant values with which the oscillator vendor confirmed normal and stable oscillation.

Table 1 Characteristics of a Sample Main System Clock Oscillator Circuit with a Ceramic Resonator

Nominal Frequency	Vendor Name	Resonator	Circuit Constant				Operating Voltage Range [V]	Oscillation Stabilization Time		Remarks
			C3 [pF]	C4 [pF]	Rf [Ω]	Rd2 [Ω]		typ [ms]	max [ms]	
12MHz	MURATA	CSTCE12M0G52-R0	(10)	(10)	OPEN	470	2.4 to 5.5	0.02	0.2	C1, C2 integrated type
8MHz		CSTCE8M00G52-R0	(10)	(10)	OPEN	1k	2.3 to 5.5	0.02	0.2	C1, C2 integrated type
		CSTLS8M00G53-B0	(15)	(15)	OPEN	1k	2.5 to 5.5	0.02	0.2	C1, C2 integrated type
4MHz		CSTCR4M00G53-R0	(15)	(15)	OPEN	1.5k	2.2 to 5.5	0.02	0.2	C1, C2 integrated type
		CSTLS4M00G53-B0	(15)	(15)	OPEN	1.5k	2.3 to 5.5	0.02	0.2	C1, C2 integrated type

The oscillation stabilization time refers to the time interval that is required for the oscillation to get stabilized after VDD goes above the lower limit level of the operating voltage range (see Figure 4)

Characteristics of a Sample System Clock Oscillator Circuit

Given below are the characteristics of a sample subsystem clock oscillation circuit that are measured using a SANYO-designated oscillation characteristics evaluation board and external components with circuit constant values with which the oscillator vendor confirmed normal and stable oscillation.

Table 2 Characteristics of a Sample Subsystem Clock Oscillator Circuit with a Crystal Resonator

Nominal Frequency	Vendor Name	Oscillator Name	Circuit Constant				Operating Voltage Range [V]	Oscillation Stabilization Time		Remarks
			C3 [pF]	C4 [pF]	Rf2 [Ω]	Rd2 [Ω]		typ [s]	max [s]	
32.768kHz	EPSON TOYOCOM	MC-306	10	10	OPEN	0	2.2 to 5.5	0.8	2	Applicable CL value=7.0pF

The oscillation stabilization time refers to the time interval that is required for the oscillation to get stabilized after the instruction for starting the subclock oscillator circuit is executed plus the time interval that is required for the oscillation to get stabilized after the HOLD mode is released (see Figure 4).

Note: The traces to and from the components that are involved in oscillation should be kept as short as possible as the oscillation characteristics are affected by their trace pattern.

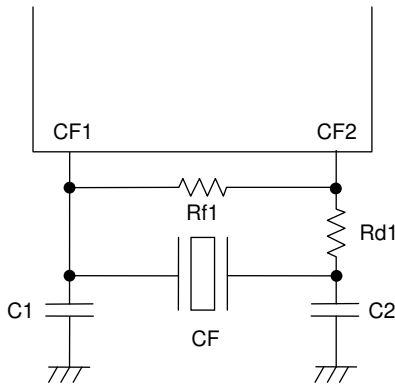

Figure 1 CF Oscillator Circuit

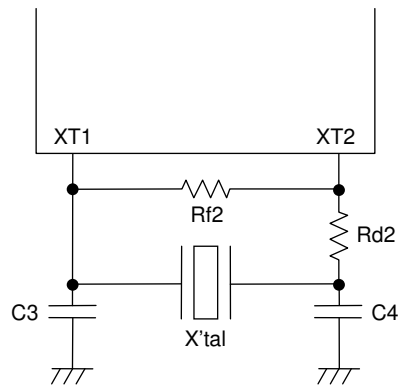

Figure 2 XT Oscillator Circuit

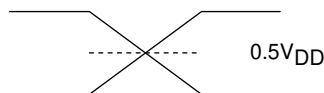
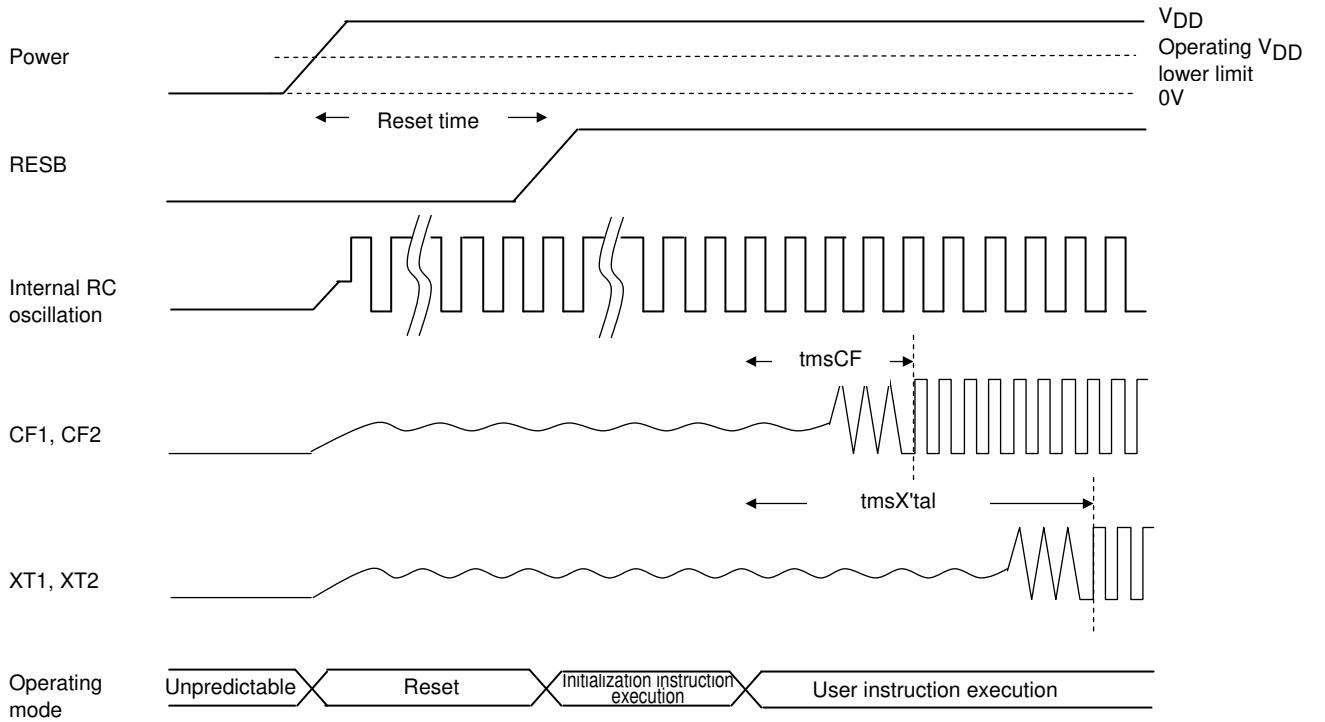
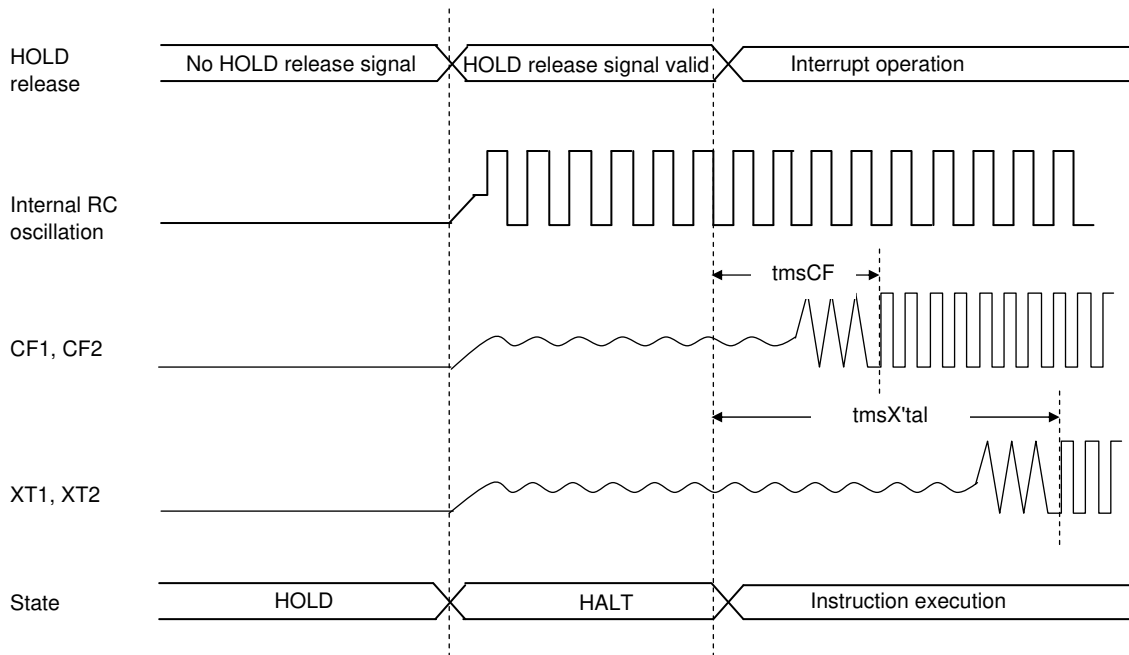

Figure 3 AC Timing Measurement Point

LC88F52H0A



Reset Time and Oscillation Stabilization Time



HOLD Release and Oscillation Stabilization Time

Figure 4 Oscillation Stabilization Time Timing Charts

LC88F52H0A

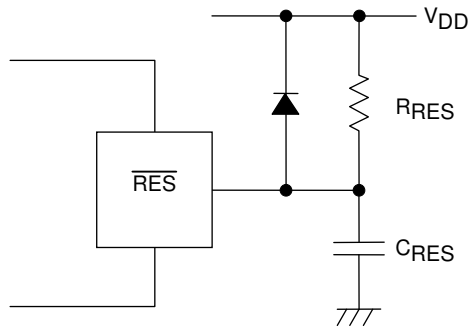

Note:
Reset signal must be present when power supply rises.
Determine the value of C_{RES} and R_{RES} so that the reset signal is present for $10\mu s$ after the supply voltage gets stabilized.

Figure 5 Reset Circuit

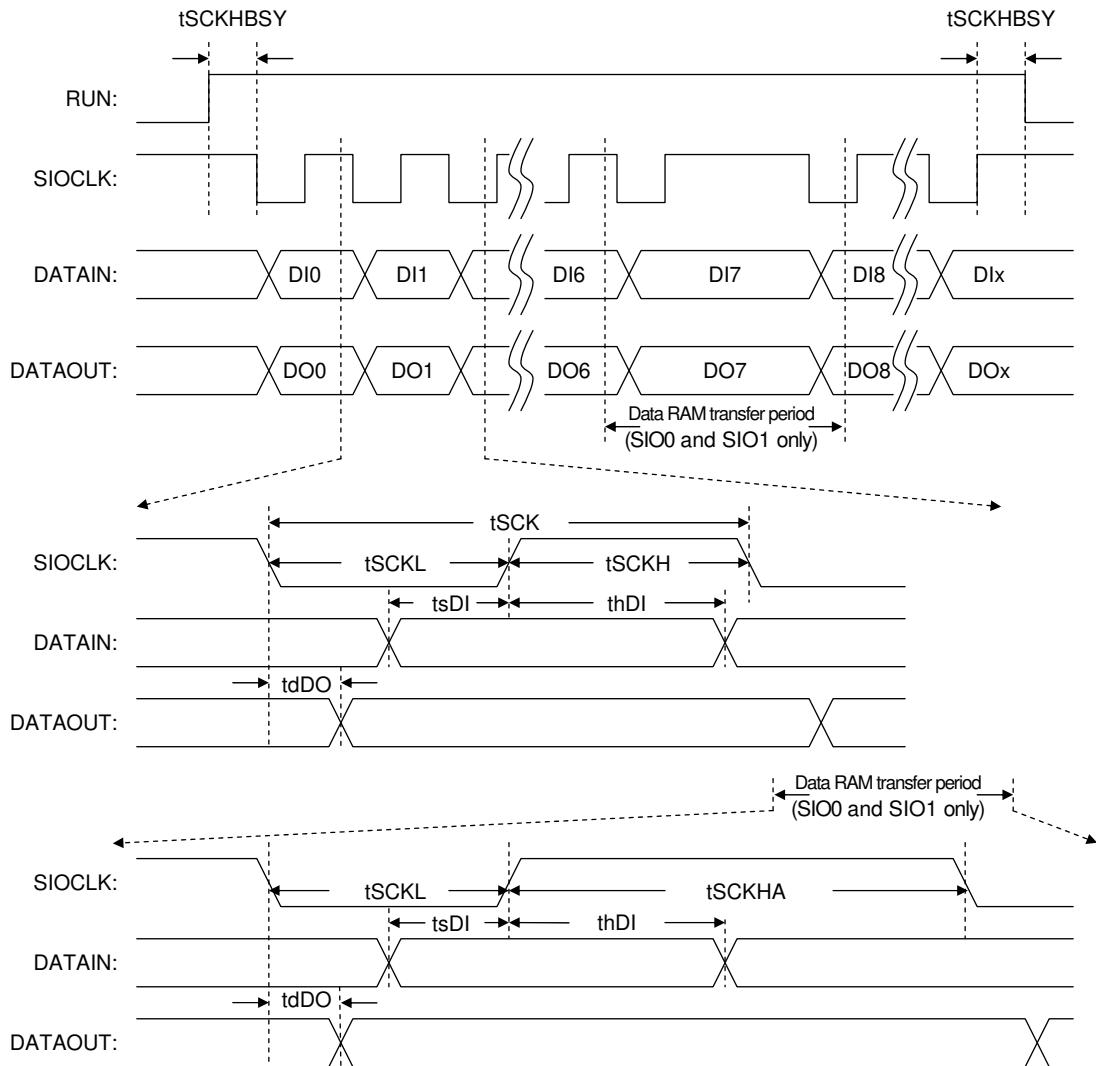

*: * Remarks: DIx and DOx denote the last bits communicated; x = 0 to 32768

Figure 6 Serial I/O Waveforms

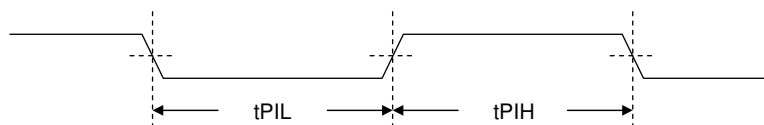
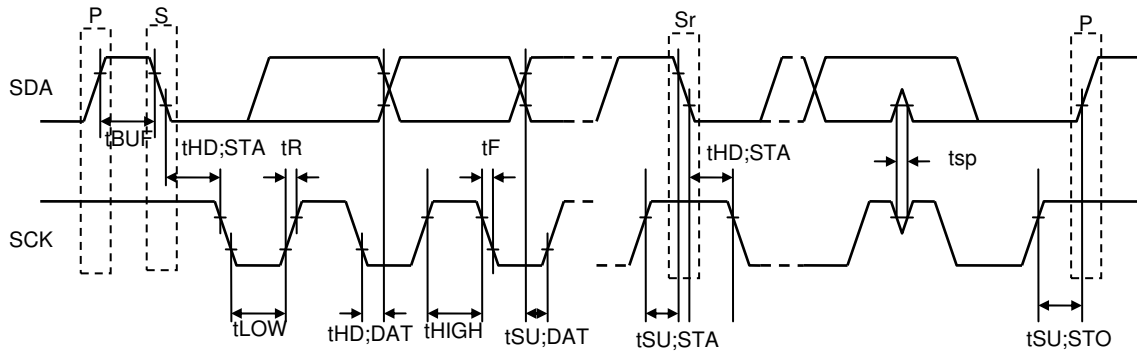

Figure 7 Pulse Input Timing Signal Waveform



S: Start condition
 P: Stop condition
 Sr: Restart condition

Figure 8 I²C Timing

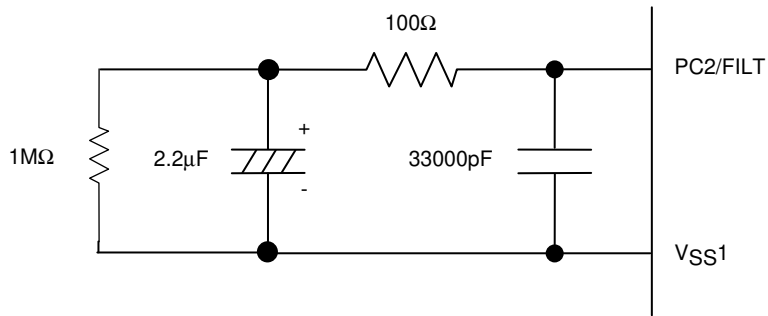

Figure 9 FILT recommended circuit

*Take at least 50ms to oscillation to stabilize after PLL is started.

- SANYO Semiconductor Co.,Ltd. assumes no responsibility for equipment failures that result from using products at values that exceed, even momentarily, rated values (such as maximum ratings, operating condition ranges, or other parameters) listed in products specifications of any and all SANYO Semiconductor Co.,Ltd. products described or contained herein.
- SANYO Semiconductor Co.,Ltd. strives to supply high-quality high-reliability products, however, any and all semiconductor products fail or malfunction with some probability. It is possible that these probabilistic failures or malfunction could give rise to accidents or events that could endanger human lives, trouble that could give rise to smoke or fire, or accidents that could cause damage to other property. When designing equipment, adopt safety measures so that these kinds of accidents or events cannot occur. Such measures include but are not limited to protective circuits and error prevention circuits for safe design, redundant design, and structural design.
- In the event that any or all SANYO Semiconductor Co.,Ltd. products described or contained herein are controlled under any of applicable local export control laws and regulations, such products may require the export license from the authorities concerned in accordance with the above law.
- No part of this publication may be reproduced or transmitted in any form or by any means, electronic or mechanical, including photocopying and recording, or any information storage or retrieval system, or otherwise, without the prior written consent of SANYO Semiconductor Co.,Ltd.
- Any and all information described or contained herein are subject to change without notice due to product/technology improvement, etc. When designing equipment, refer to the "Delivery Specification" for the SANYO Semiconductor Co.,Ltd. product that you intend to use.
- Information (including circuit diagrams and circuit parameters) herein is for example only; it is not guaranteed for volume production.
- Upon using the technical information or products described herein, neither warranty nor license shall be granted with regard to intellectual property rights or any other rights of SANYO Semiconductor Co.,Ltd. or any third party. SANYO Semiconductor Co.,Ltd. shall not be liable for any claim or suits with regard to a third party's intellectual property rights which has resulted from the use of the technical information and products mentioned above.

This catalog provides information as of March, 2010. Specifications and information herein are subject to change without notice.