

THIS DRAWING IS UNPUBLISHED. RELEASED FOR PUBLICATION  
 © COPYRIGHT BY TYCO ELECTRONICS CORPORATION. ALL RIGHTS RESERVED.

LOC		DIST		REVISIONS			
P	LTR	DESCRIPTION		DATE	DWN	APVD	
AF	50	E	REVISED PER ECR-06-010412	09NOV06	HMR	KR	

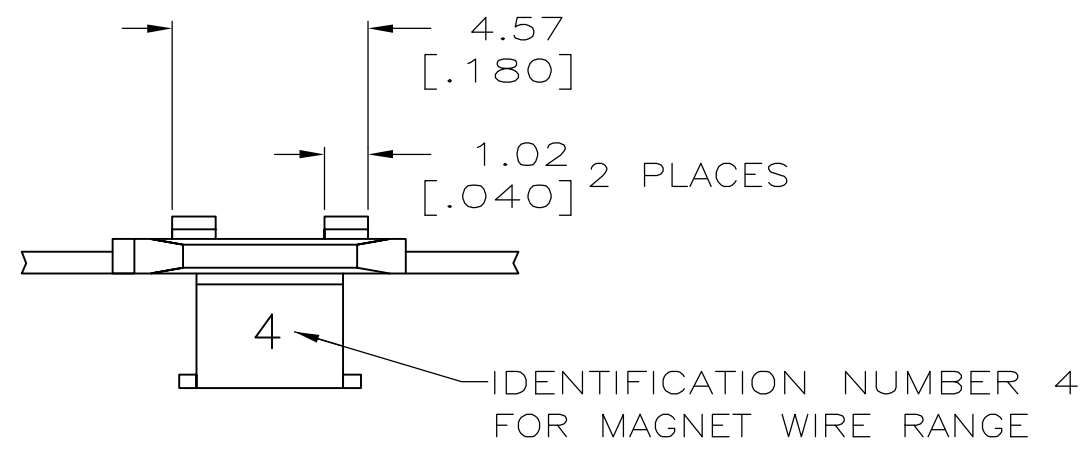

- 1 CONTINUOUS STRIP ON REELS WITH TERMINALS LOCATED ON 8.38±0.08 [.330±.003] CENTERS
- 2 SLOT ACCEPTS 0.18-0.23mm [#33-#31] AWG COPPER MAGNET WIRE. 2 WIRES OF THE SAME SIZE MAX PER SLOT.

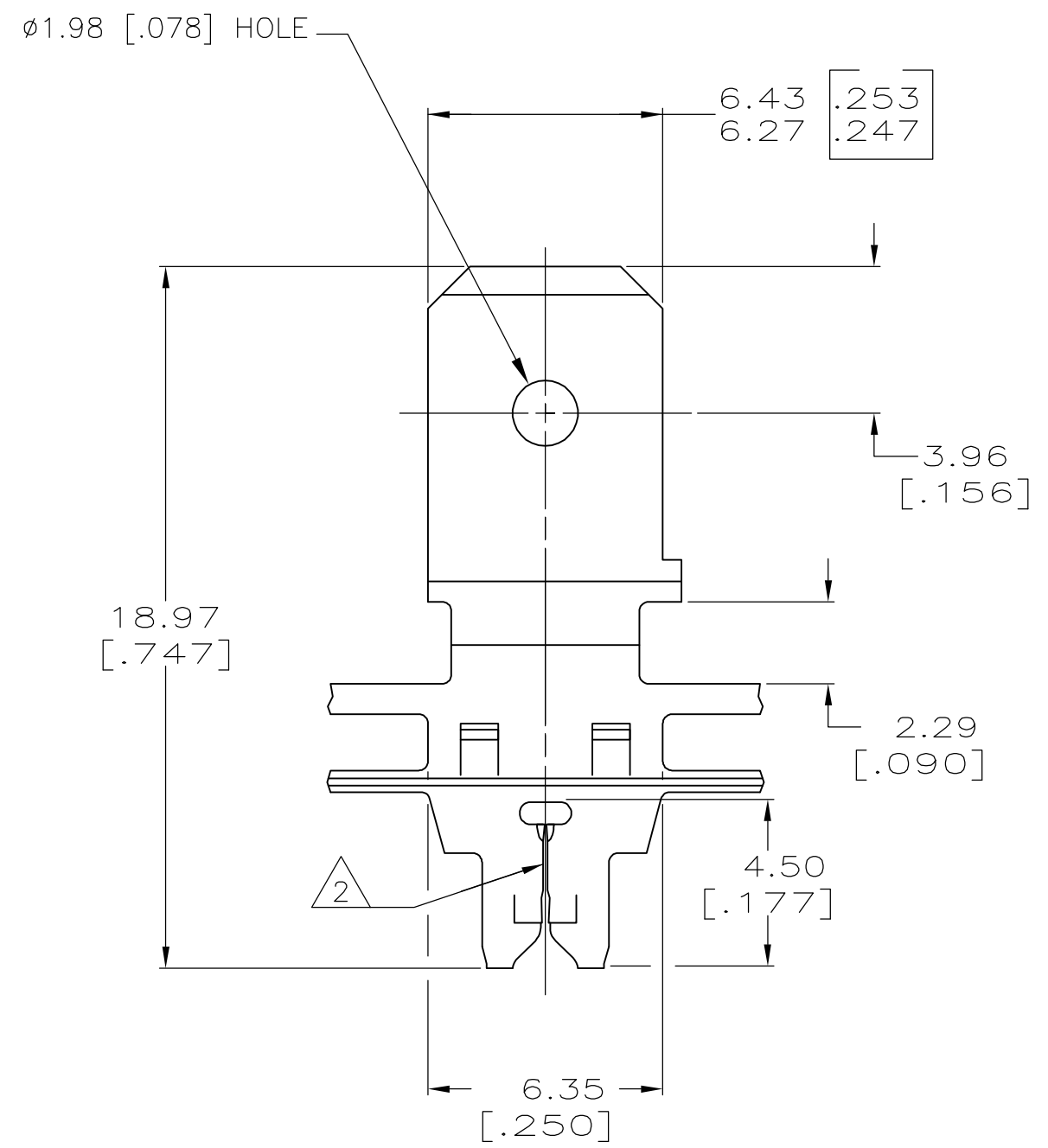
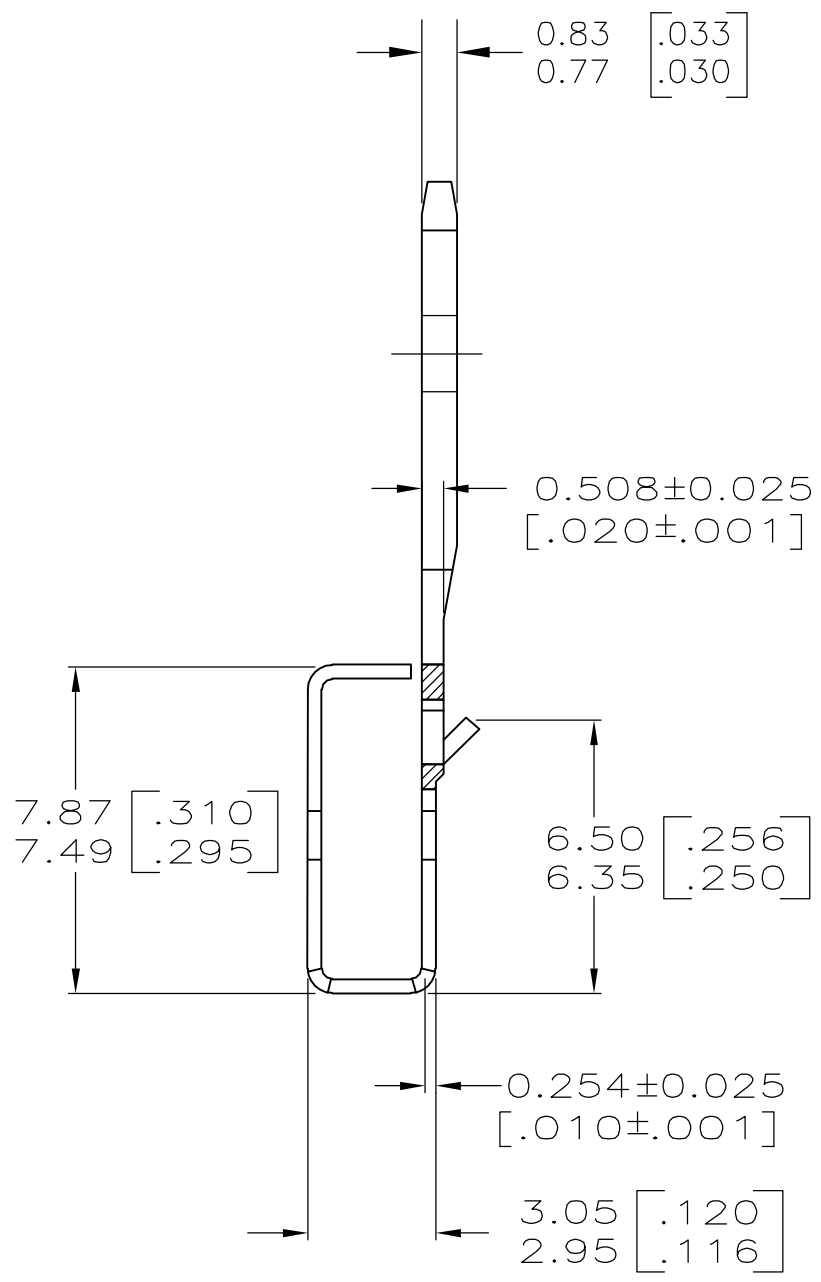
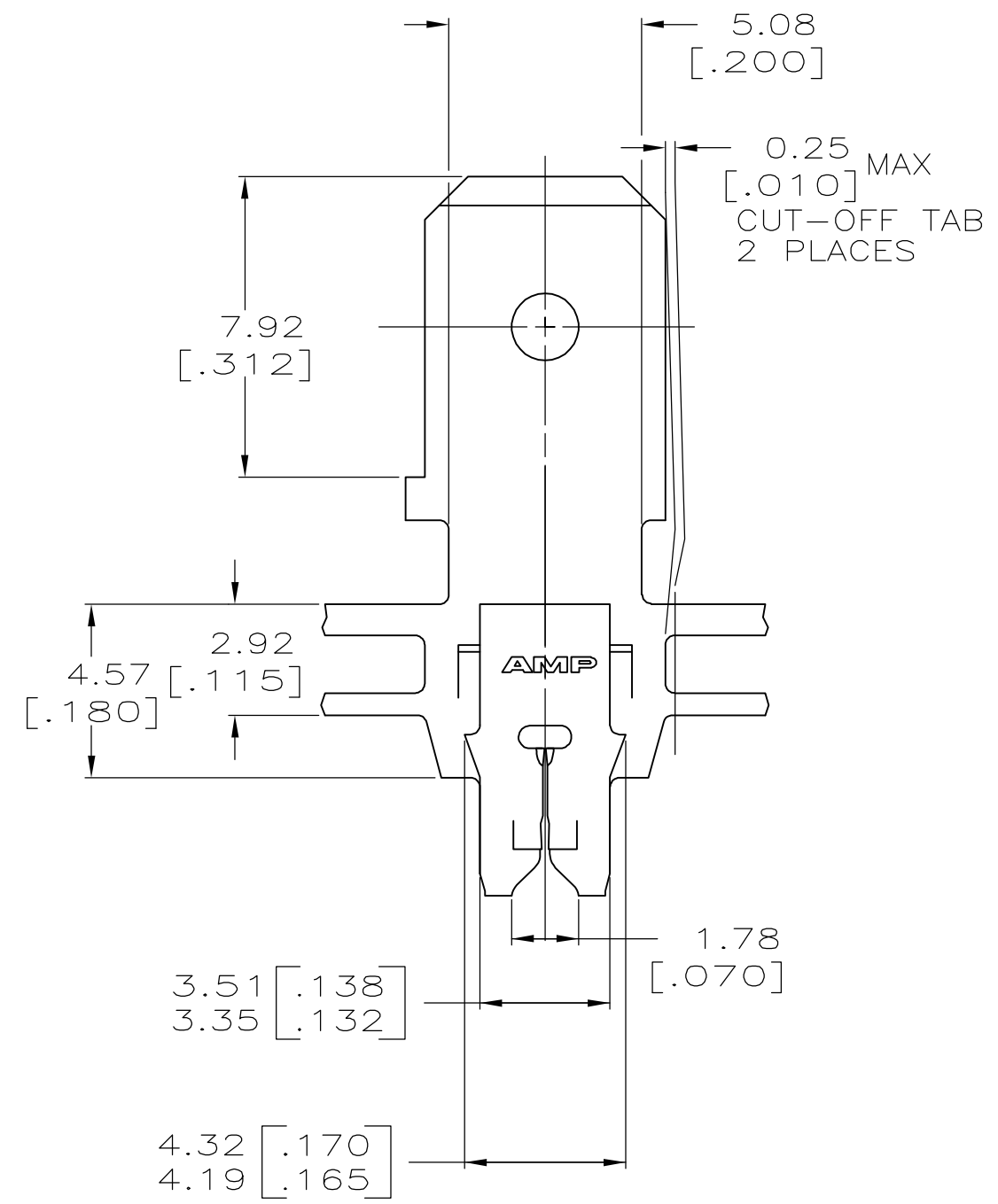

63618  
 63618-1  
 PART NUMBER

THIS DRAWING IS A CONTROLLED DOCUMENT.		DWN MICHAEL S. FEHER SR. 12/5/91	Tyco Electronics Corporation Harrisburg, PA 17105-3608	
DIMENSIONS: mm [INCHES]		CHK JEFF R. RUTH 12/9/91	APVD -	
TOLERANCES UNLESS OTHERWISE SPECIFIED:		NAME TAB, 6.35 [.250] FASTON, MAG-MATE		
0 PLC ± -		PRODUCT SPEC 108-2012		
1 PLC ± -		APPLICATION SPEC 114-2094		
2 PLC ± 0.25 [.010]		SIZE A2		
3 PLC ± -		CAGE CODE 00779		
4 PLC ± -		DRAWING NO G-63618		
ANGLES ± -		RESTRICTED TO -		
MATERIAL 4M PRE-MILLED BRASS	FINISH 0.002032 [.000080] MIN TIN	WEIGHT -		
CUSTOMER DRAWING		SCALE 6:1 SHEET 1 OF 1 REV E		