

# Development Board EPC9205 Quick Start Guide

*eGaN<sup>®</sup> FET Power Module, Using 100 V EPC2045*

Revision 1.0



**DESCRIPTION**

The EPC9205 development board provides an eGaN FET based power module, featuring the EPC2045 eGaN FET (Enhancement-mode Gallium Nitride Field Effect Transistor). The purpose of this development board is to simplify the evaluation process of the EPC2045 eGaN FET by including all the critical components on a single board that can be easily connected into any existing system.

The EPC9205 development board is 13.5 mm x 22 mm x 5 mm and contains two EPC2045 eGaN FETs in a half-bridge configuration, in combination with the UPI UP1966A gate driver. The board also contains all critical components and layout for optimal switching performance. A block diagram of the circuit is given in Figure 1.

For more information on the EPC2045, please refer to the datasheet available from EPC at [www.epc-co.com](http://www.epc-co.com). The datasheet should be read in conjunction with this quick start guide.

**QUICK START PROCEDURE**

Development board EPC9205 is easy to set up to evaluate the performance of the EPC2045 eGaN FET. Refer to Figure 10 for pin descriptions, and follow the procedure below:

1. With power off, connect the input power supply bus to +V<sub>IN</sub> and ground / return to PGND.
2. With power off, connect +V<sub>OUT</sub> to your circuit as required.
3. With power off, connect the gate drive input to +V<sub>CC</sub> and ground return to AGND.
4. With power off, connect the input PWM control signals to HIN and LIN referenced to AGND. Note: This board does not have shoot-through protection and it is recommended to use a larger initial dead-time, or blanking period between the HIN and LIN signals to begin. Once converter operation is verified, the dead-time can be reduced to a value determined by the user. The EPC recommended dead-time for the typical operating conditions is 10 ns for each edge, shown in figure 2.
5. Turn on the gate drive supply – make sure the supply is between 4.5 V and 5.5 V range.
6. Turn on the controller / PWM input source for both high-side and low-side FETs.
7. Turn on the bus voltage to the required value (do not exceed the absolute maximum voltage).
8. Once operational, adjust the PWM control, bus voltage, and load within the operating range and observe the output switching behavior, efficiency and other parameters.
9. For shutdown, please follow steps in reverse.

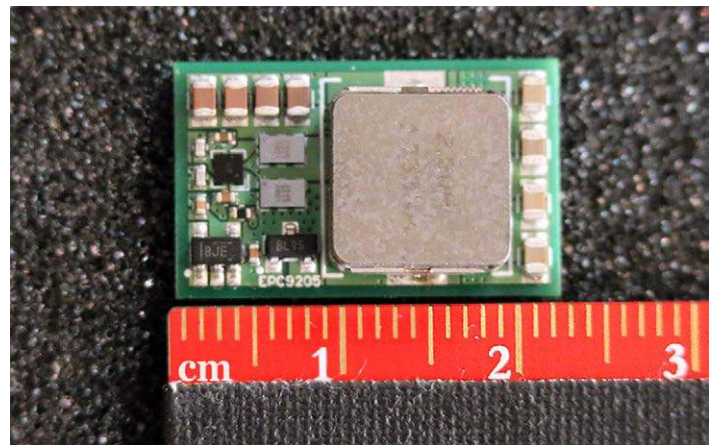

EPC9205 Top View

Table 1: Performance Summary (T<sub>A</sub> = 25°C) EPC9205

Symbol	Parameter	Conditions	Min	Typ	Max	Units
V <sub>CC</sub>	Gate Drive Input Supply Range		4.5	5	5.5	V
V <sub>IN</sub>	Bus Input Voltage Range (1)			48	80	V
I <sub>OUT</sub>	Switch Node Output Current (2)			10		A
f <sub>sw</sub>	Target Switching Frequency			700		kHz
V <sub>PWM</sub>	PWM Logic Input Voltage Threshold	Input 'High' Input 'Low'	2.3 0		5 0.5	V V
	Minimum 'High' State Input Pulse Width	V <sub>PWM</sub> rise and fall time < 10 ns	25			ns

(1) Maximum switch node ringing must be kept under 100 V for EPC2045.  
 (2) Maximum current depends on die temperature – actual maximum current will be subject to switching frequency, bus voltage and thermal cooling.

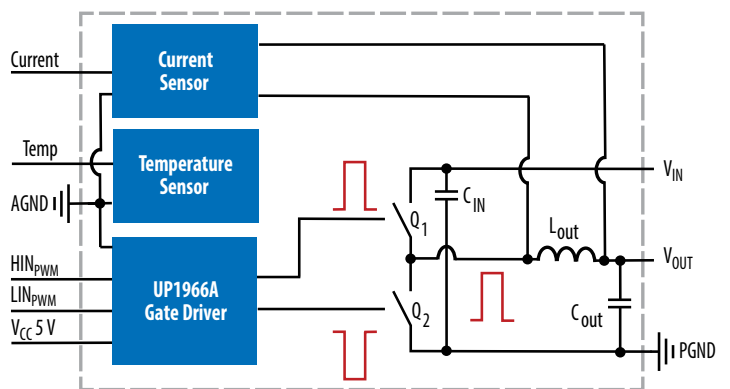

Note: AGND and PGND are tied on the EPC9205 and do not need to be tied externally

Figure 1. Block Diagram of EPC9205 Development Board.

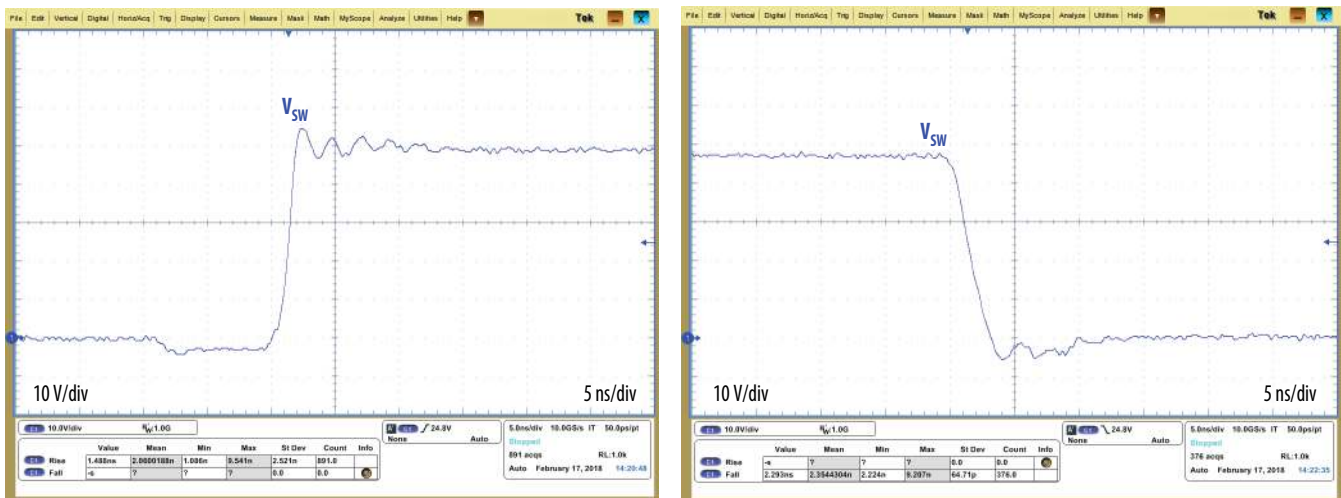
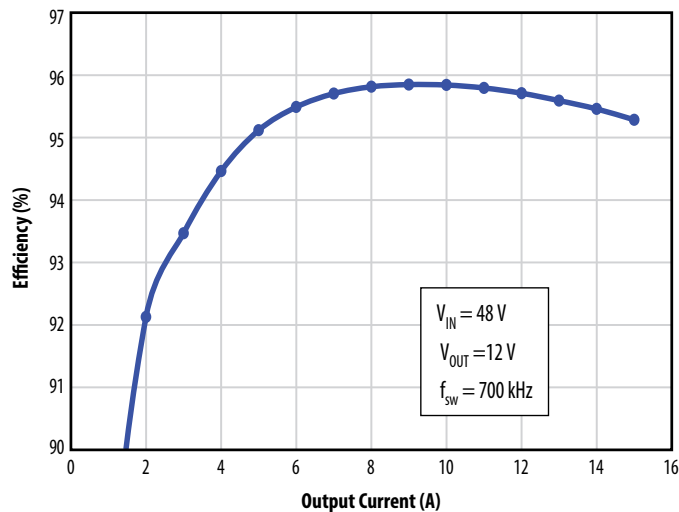

Figure 2: Typical Waveform for  $V_{IN} = 48\text{ V}$  to  $12\text{ V}_{OUT}$ , 10 A, 700 kHz Buck Converter



**Note:** Total system efficiency including power stage, inductor, driver, capacitors, and PCB losses.

Figure 3: Typical System Efficiency for  $V_{IN} = 48\text{ V}$  to  $12\text{ V}_{OUT}$  Buck Converter

### THERMAL CONSIDERATIONS

The EPC9205 development board showcases the EPC2045 eGaN FET. The EPC9205 is intended for bench evaluation. The addition of heat-sinking and forced air cooling can significantly increase the current rating of these devices, but care must be taken to not exceed the absolute maximum die temperature of  $150^{\circ}\text{C}$ . An example thermal image is shown in Figure 4 for typical operating conditions.

For more information regarding the thermal performance of EPC eGaN FETs, please consult:

D. Reusch and J. Glaser, *DC-DC Converter Handbook*, a supplement to GaN Transistors for Efficient Power Conversion, First Edition, Power Conversion Publications, 2015.

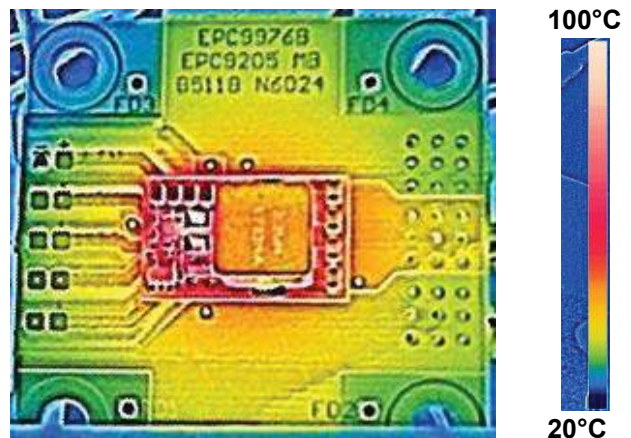

**Note:** Max eGaN FET case temperature =  $100^{\circ}\text{C}$

Figure 4: Thermal image for  $V_{IN} = 48\text{ V}$  to  $12\text{ V}_{OUT}$ , 10 A, 700 kHz, 400 LFM airflow.

## CURRENT & TEMPERATURE SENSING

The EPC9205 includes an optional output current sensing circuit using the TI INA196 current shunt monitor, which is disabled by default. To enable the sensor, optional components  $R_s$  and  $C_s$  can be populated with 1.6 k $\Omega$  and 150 nF respectively, as specified in the BOM below. Enabling this circuit contributes approximately 200 mW of additional power loss to the EPC9205. The output voltage characteristic of this sensing circuit on the EPC9205 is shown in Figure 5.

The EPC9205 also includes temperature sensing, using the Microchip TC1047A precision temperature-to-voltage converter. An example output voltage characteristic of this sensor on the EPC9205 is shown in Figure 6.

**Note:** The on-board temperature sensor reflects the temperature of the PCB. The relationship between sensor output voltage and eGaN FET temperature may vary with operating conditions and thermal design, and it should be calibrated for a given test setup. Figure 6 shows an example of this calibration curve in one test case.

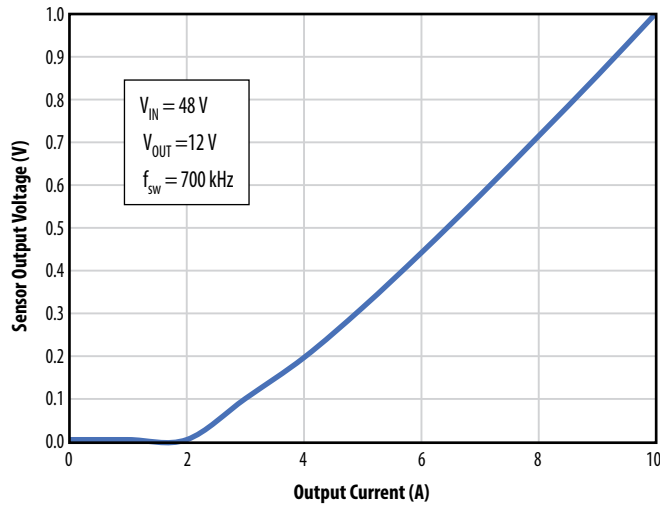

**Note:** Current sense is optional on this development board and not enabled by default.

Figure 5: Current Sensor Output Curve for EPC9205 Development Board with  $V_{IN} = 48\text{ V}$  to  $12\text{ V}_{OUT}$ , 700 kHz

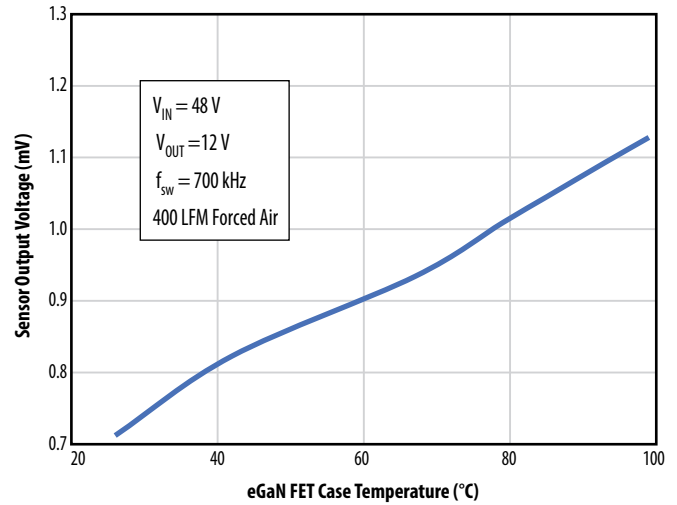

Figure 6: Example Temperature Sensor Output Curve for EPC9205 Development Board with  $V_{IN} = 48\text{ V}$  to  $12\text{ V}_{OUT}$ , 700 kHz, 400 LFM Forced Air Cooling

## DESIGN CONSIDERATIONS

To improve the electrical and thermal performance of the EPC9205 development board, some design considerations are recommended:

1. Large copper planes should be connected to the development board to improve thermal performance as shown in Figures 7 and 8. If filled vias are used in the board design, thermal vias should be placed under the device to better distribute heat through buried inner layers. For a design without filled vias, thermal vias should be located outside of the development board.
2. The gate drive ground return connection (AGND, pin 4 in mechanical drawings), is connected on the EPC9205 board should be isolated from the power ground connection (pins 7,8,9,11 in mechanical drawings).
3. If additional input filter capacitance is required, it can be placed outside the module. Due to the internal on-board input capacitance, minimizing the distance of the additional input capacitors to the development board, while preferred, is not a design requirement.

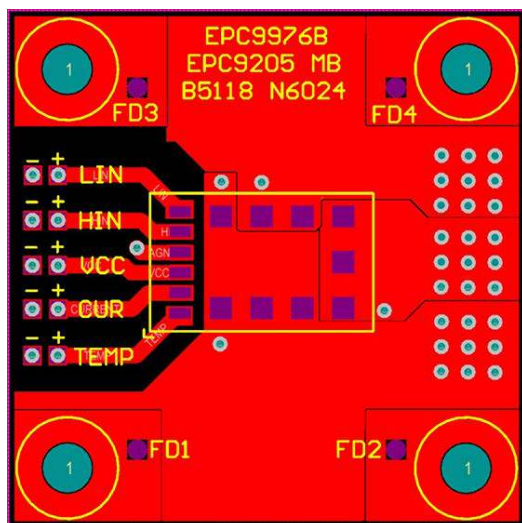

Figure 7: Top layer without filled thermal vias.

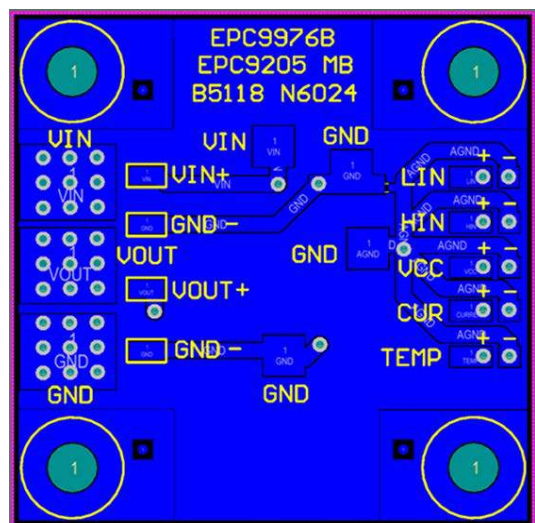
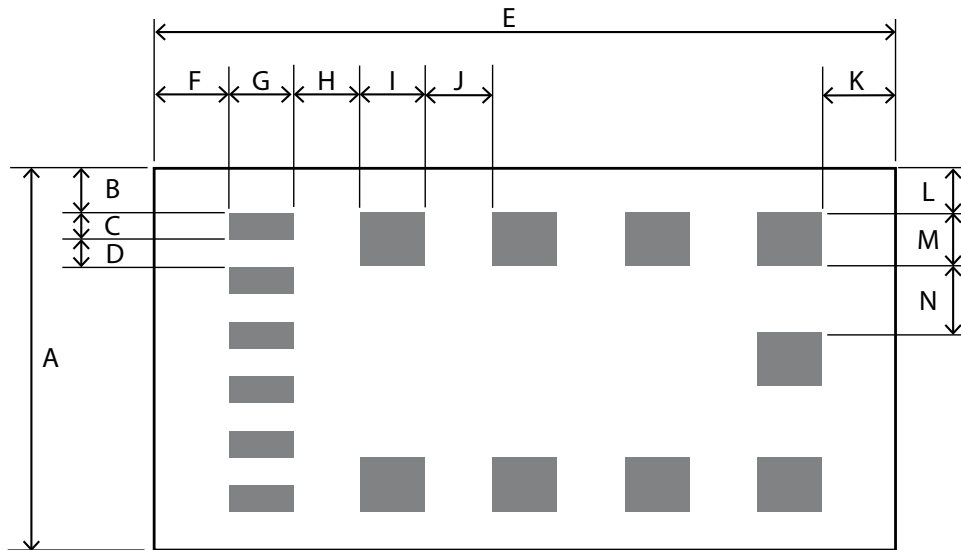

Figure 8: Bottom layer layout.

MECHANICAL DATA



Symbol	Dimension
A	13.6 mm
B	1.3 mm
C	1 mm
D	1 mm
E	22 mm
F	2 mm
G	2 mm
H	2 mm
I	2 mm
J	2 mm
K	2 mm
L	1.3 mm
M	2 mm
N	2.5 mm

Figure 9: Footprint mechanical outline and pin numbering. (Top view)

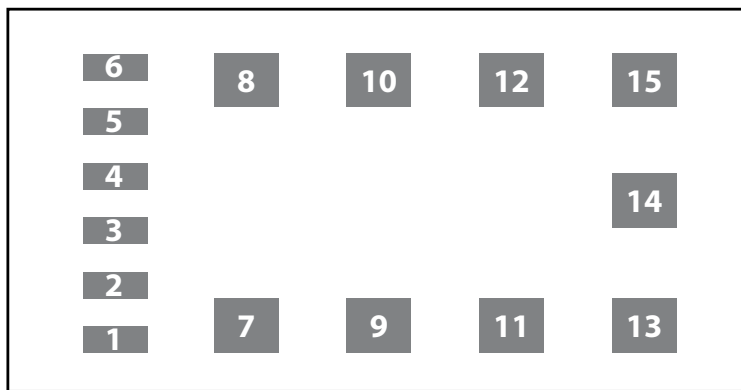

Pin	Type
1	Temp
2	Current
3	V <sub>CC</sub>
4	AGND
5	HIN <sub>PWM</sub>
6	LIN <sub>PWM</sub>
7, 8, 9, 11	PGND
10, 12	V <sub>IN</sub>
13, 14, 15	V <sub>OUT</sub>

Figure 10: Pin Descriptions. (Top view)

Table 2: Bill of Materials

Item	Qty	Reference	Part Description	Manufacturer	Part #
1	4	CIN1, CIN2, CIN3, CIN4	Cap, ceramic, 1µF, 100 V, X7S, 0805	TDK	C2012X7S2A105M125AB
2	2	Q1, Q2	eGaN FET, 100 V	EPC	EPC2045
3	1	CB	Cap, ceramic, 0.1 µF, 25 V, X5R, 0402	TDK	C1005X5R1E104K050BC
4	2	CDEC, CDEC2	Cap, ceramic, 1 µF, 25 V, X5R, 0402	TDK	C1005X5R1E105K050BC
5	2	CDEC3, CDEC4	Cap, ceramic, 22 pF, 50 V, COG, 0402	Kemet	CBR04C220F5GAC
6	1	U1	Gate Drive IC, dual	UPI	uP1966A
7	4	COUT1, COUT2, COUT3, COUT4	Cap, ceramic, 22 µF, 25 V, X5R, 0805	Murata	GRT21BR61E226ME13L
8	1	L1	Inductor, 2.2 µH, 20%, 12 A	Vishay	IHLP4040DZER2R2M01
9	1	U3	Temperature sensor IC, analog	Microchip	TC1047AVNBTR
10	1	U2	Current sense amplifier IC	TI	INA196AIDBVR

Table 3: Optional Components

Item	Qty	Reference	Part Description	Footprint
1	1	CS	Capacitor, ceramic, 15 nF, 16 V	0402
2	1	RS	Res, 1.62 k, 1/16 W	0402

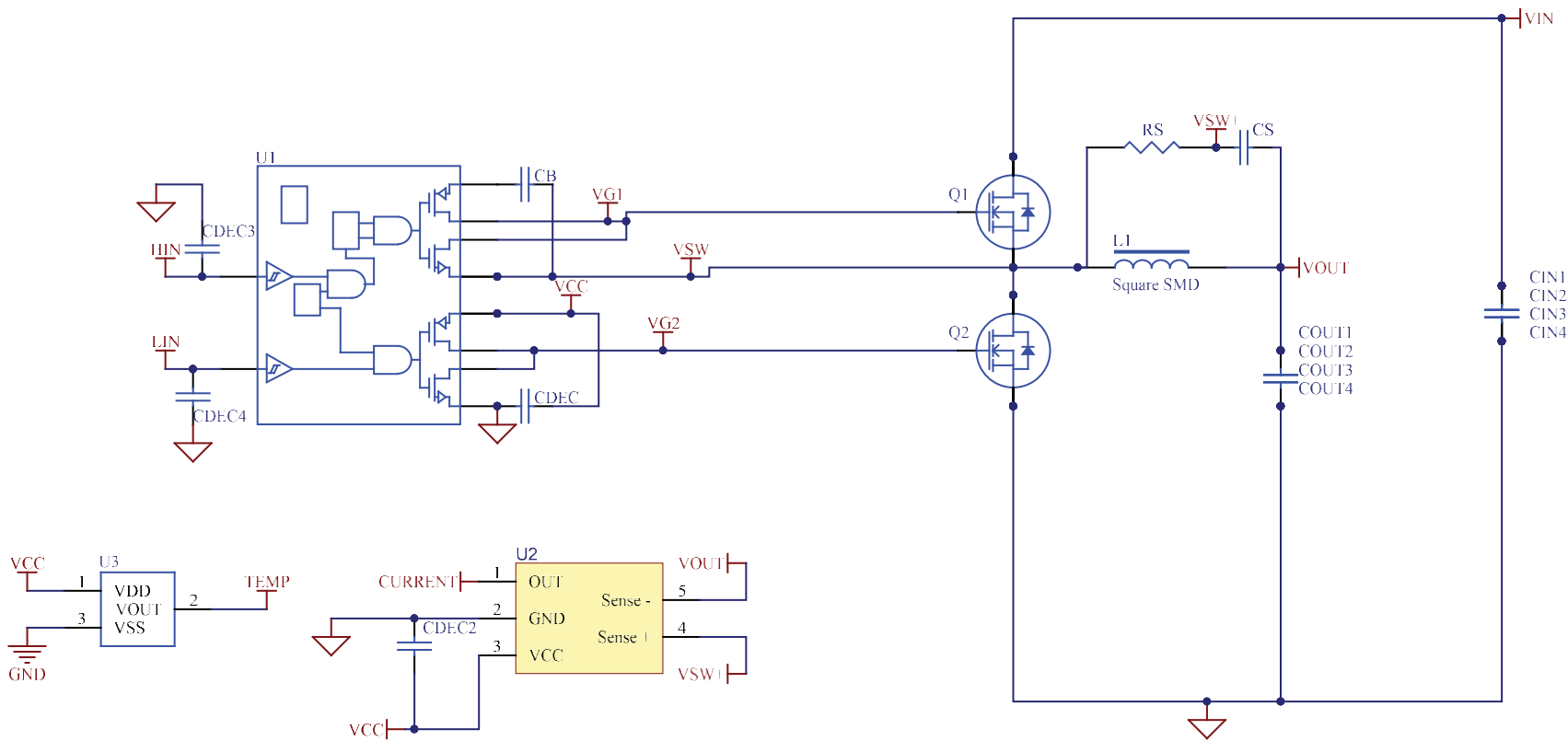

Figure 11: EPC9205 schematic

## For More Information:

Please contact [info@epc-co.com](mailto:info@epc-co.com)  
or your local sales representative

Visit our website:  
[www.epc-co.com](http://www.epc-co.com)

Sign-up to receive  
EPC updates at  
[bit.ly/EPCupdates](http://bit.ly/EPCupdates)  
or text "EPC" to 22828



EPC Products are distributed through Digi-Key.  
[www.digikey.com](http://www.digikey.com)

### Demonstration Board Notification

The EPC9205 board is intended for product evaluation purposes only and is not intended for commercial use. Replace components on the Evaluation Board only with those parts shown on the parts list (or Bill of Materials) in the Quick Start Guide. Contact an authorized EPC representative with any questions.

This board is intended to be used by certified professionals, in a lab environment, following proper safety procedures. Use at your own risk.

As an evaluation tool, this board is not designed for compliance with the European Union directive on electromagnetic compatibility or any other such directives or regulations. As board builds are at times subject to product availability, it is possible that boards may contain components or assembly materials that are not RoHS compliant. Efficient Power Conversion Corporation (EPC) makes no guarantee that the purchased board is 100% RoHS compliant.

The Evaluation board (or kit) is for demonstration purposes only and neither the Board nor this Quick Start Guide constitute a sales contract or create any kind of warranty, whether express or implied, as to the applications or products involved.

Disclaimer: EPC reserves the right at any time, without notice, to make changes to any products described herein to improve reliability, function, or design. EPC does not assume any liability arising out of the application or use of any product or circuit described herein; neither does it convey any license under its patent rights, or other intellectual property whatsoever, nor the rights of others.