

Order Number
213069-0700

molex[®]

Application Tooling Specification

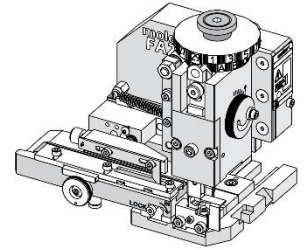

FEATURES

- Applicator designed to industry-standard mounting and 135.80mm (5.346") shut height
- Quick setup time; plus, the crimp height, track and feed adjustments can be set without removing the applicator from the press
- Fine adjustment allows users to achieve target with little effort by adjusting in increments of .015mm (.0006") for conductor crimp height and .025mm (.001") for insulation height
- Independent adjustment rings allow users to quickly adjust the conductor or insulation crimp height without affecting each other
- Directly adapts to most automatic wire processing machines

SCOPE

Products: Squba 3.6 Large Blade, 16 AWG wire.

Terminal Series No.	Terminal Order No.	Wire		Insulation Diameter		Strip Length	
		Wire Type	Size	mm	In.	mm	In.
207776	207776-0001	UL1007	16 AWG	2.40 max	.094 max	4.00-4.50	.157-.177
		UL1061	16 AWG	1.90 min	.075 min	4.00-4.50	.157-.177

CAUTION: Lubrication must be used to prevent terminals from sticking in the conductor punch. Use 63801-7240 oiler or equivalent.

DEFINITION OF TERMS

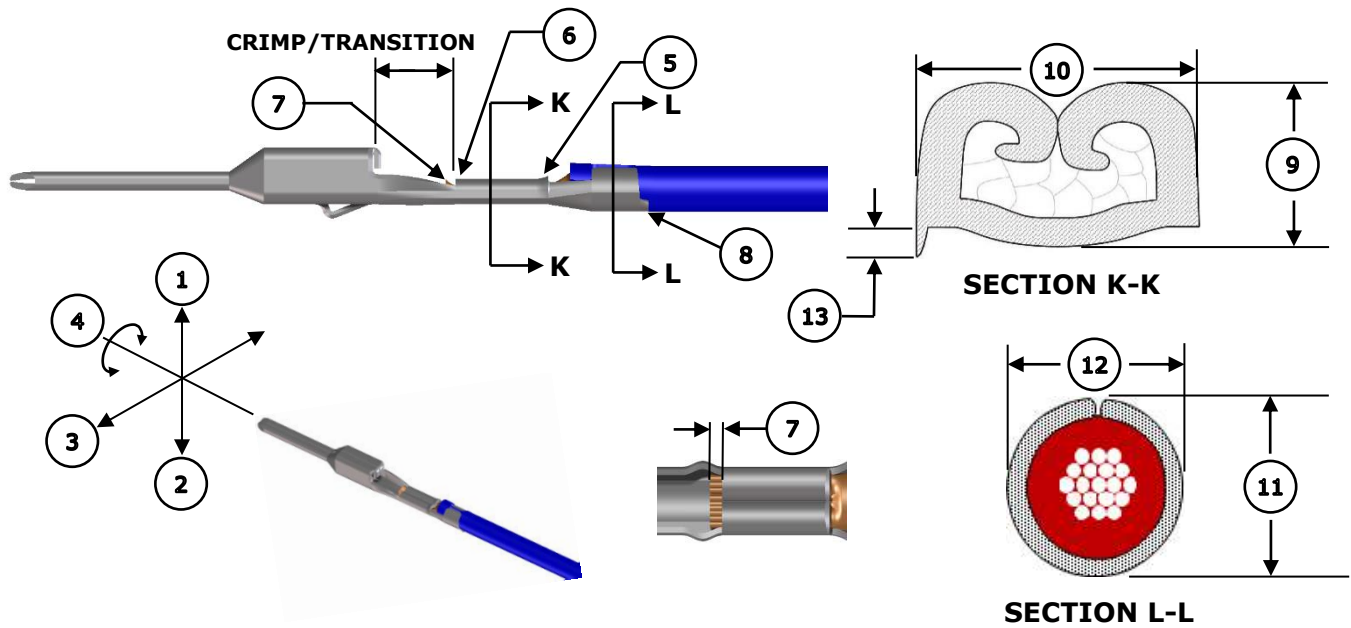

The above terminal drawing is a generic terminal representation. It is not an image of a terminal listed in the scope.

CRIMP SPECIFICATIONS

Feature	Requirement
1. Bend Up	3° Max
2. Bend Down	3° Max
3. Twist	3° Max
4. Roll	3° Max
5. Bell Mouth Rear	0.40-0.60mm (.016-.024")
6. Bell Mouth Front	Not Applicable
7. Conductor Brush	0.30-0.70mm (.012-.028")
8. Cut-Off Tab	0.20mm (.008") Max
Conductor Crimp	Wire Type Wire Size 9. Crimp Height 10. Crimp Width
	UL1007 16 AWG 1.40-1.50mm .055-.059 in. 1.80-1.90mm .071-.075 in.
	UL1061 16 AWG 1.40-1.50mm .055-.059 in. 1.80-1.90mm .071-.075 in.
Insulation Crimp	Wire Type Wire Size 11. Crimp Height 12. Crimp Width
	UL1007 16 AWG 2.65-2.75mm .104-.108 in. 2.45-2.55mm .096-.100 in.
	UL1061 16 AWG 2.25-2.35mm .089-.093 in. 2.37-2.47mm .093-.097 in.
Pull Force	Wire Type Wire Size Minimum Force
	UL1007 16 AWG 133.5 N 30.0 lb.
	UL1061 16 AWG 133.5 N 30.0 lb.
13. Conductor Anvil Flash	0.15mm (.006") Max

NOTES

Applicator Notes

- This applicator is for automatic wire processor use only.
- This applicator does not include a cutting insert.
- Installing a cutting insert will cause jamming in this applicator.
- Lubrication must be used to prevent terminals from sticking in the conductor punch. Use 63801-7240 oiler or equivalent.

CUTTING INSERT

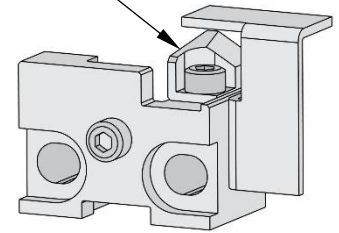

Specification Notes

- It is very important that the brush length is consistently within specification for this sealed connector system to work properly.
- This applicator should only be run in a properly set up wire processor to consistently achieve the brush length.

General Notes

1. Molex recommends that an extra perishable tooling kit be maintained at your facility.
2. Verify tooling alignment by hand cycling the press and applicator before crimping under power. Check that all screws are tight.
3. Slugs, terminals, dirt and oil should be kept clear of the work area.
4. Wear safety glasses at all times.
5. For recommended maintenance, refer to the FA2 manual (TM-638080200).
6. Molex recommends crimping standard copper wire only.

WARNINGS

CAUTION: This applicator must be installed in a press with a standard shut height of 135.80mm (5.346"). Tooling damage could result at a lower setting.

CAUTION: To prevent injury, never operate this applicator without the guards supplied with the press or wire-processing machine in place. Reference the press or wire processing manufacturer's instruction manual.

CAUTION: Molex tooling crimp specifications are valid only when used with Molex terminals and tooling manufactured by Molex and sold by Molex or authorized distributors ("Molex Tooling"). When using tooling other than Molex Tooling with Molex-specific connector systems listed in our ATS documents, the Molex Tooling qualification does not apply, and the responsibility for full qualification of the connector system is that of the customer. Molex accepts no liability for connector performance or tooling support where tooling other than Molex Tooling is used or where Molex Tooling is modified.

PARTS LIST

Applicator 213069-0700				
Item	Order No.	Engineering No.	Description	Quantity
Perishable Tooling				
	213069-0770	213069-0770	Tool Kit (All "Y" Items)	Ref
1	63454-0180	63454-0180	Insulation Punch	1 Y
2	63457-0127	63457-0127	Conductor Punch	1 Y
3	63456-0120	63456-0120	Insulation Anvil	1 Y
4	63455-0170	63455-0170	Conductor Anvil	1 Y
5	63443-0122	63443-0122	Cut-Off Plunger	1 Y
Non-Perishable Components				
6	63443-0118	63443-0118	Front Plunger Retainer	1
7	63700-0992	63700-0992	Cut-Off Plunger Spring	1
8	63443-0117	63443-0117	Front Scrap Chute	1
9	63443-7547	63443-7547	Anvil Mount	1
10	63443-0090	63443-0090	Wire Stop Assembly	1
11	63443-2801	63443-2801	Front Plunger Striker	1
12	63443-2917	63443-2917	Wire Hold Down Plunger	1
13	63600-0021	63600-0021	Wire Hold Down Spring	1
14	63600-5776	63600-5776	Nose Hold Down	1
15	63600-5775	63600-5775	Nose Hold Down Shank	1
16	63443-4723	63443-4723	Terminal Guide	1
17	63443-7403	63443-7403	Hold Down Block	1
18	63808-0229	63808-0229	Bend Adjust Dial	1
19	63808-0297	63808-0297	Feed Cam	1
Frame				
20	63808-0200	63808-0200	Applicator Core	1
21	63808-0197	63808-0197	Mechanical Feed Assembly	1
22	63808-0191	63808-0191	Track Assembly	1
Hardware				
23	—	—	M2.5 x 4 SHCS	1*
24	—	—	M3 Flat Washer Hard	1*
25	—	—	M3 Hex Nut	1*
26	—	—	M3 Inner Tooth Lock Washer	1*
27	—	—	M3 x 6 BHCS	2*
28	—	—	M3 x 12 SHCS	4*
29	—	—	M4 x 5 SSS	1*
30	—	—	M4 x 6 SHCS	1*
31	—	—	M4 x 8 SHCS	2*
32	—	—	M4 x 50 SHCS	2*
33	—	—	M5 x 12 SHCS	1*
34	—	—	#10-32UNF x .25" BHCS	1*
*Fastener parts can be purchased through most industrial suppliers by using the description in the table above.				

ASSEMBLY DRAWING

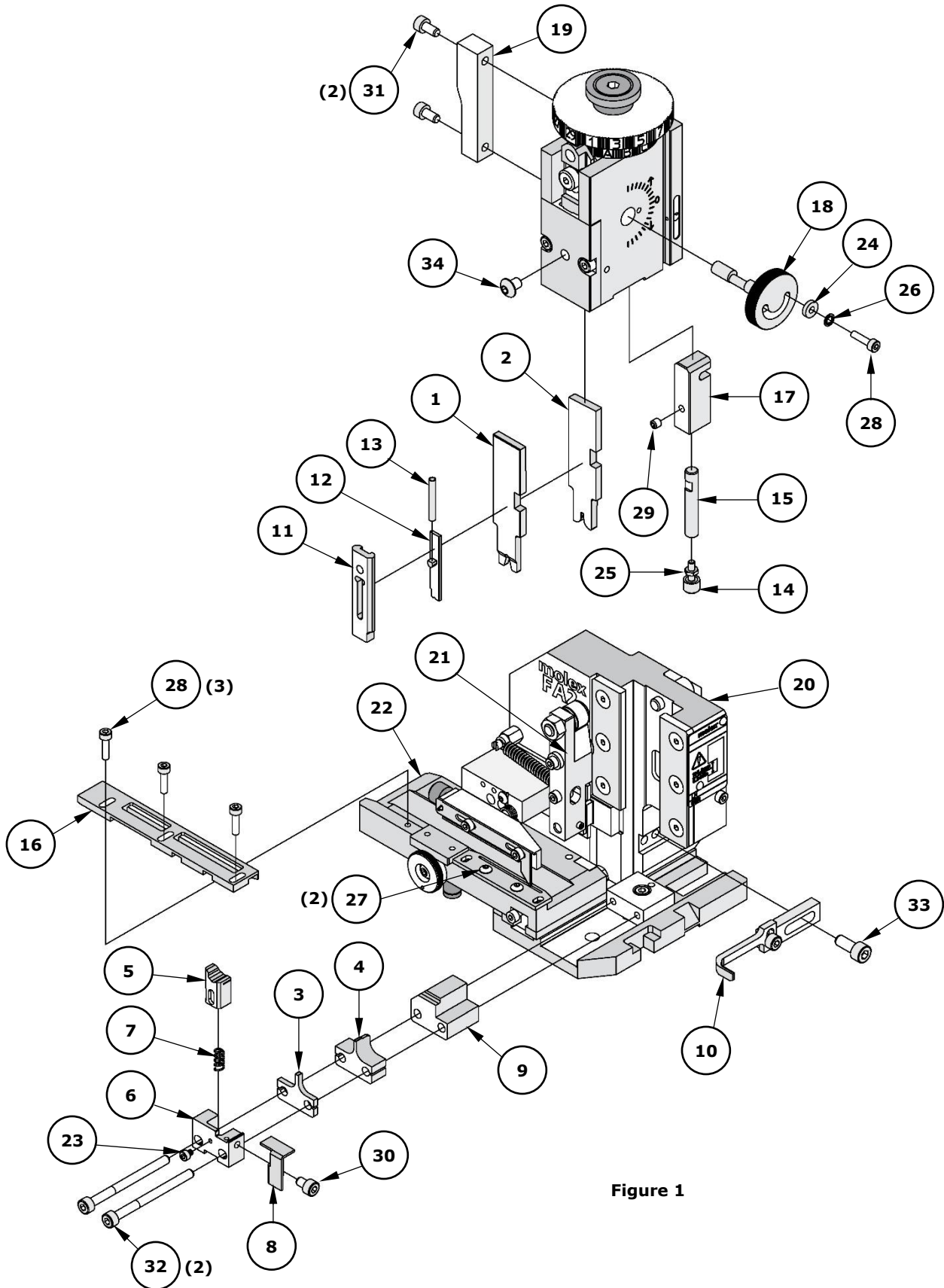

Figure 1

FACTORY SETTINGS

Feed Pawl Assembly

The FA2 applicator number 213069-0700 ships with the following factory settings. See Figure 2:

- The feed pawl shaft and M3 screw that holds the feed pawl spring are in position 3.
- The pin is in position B.

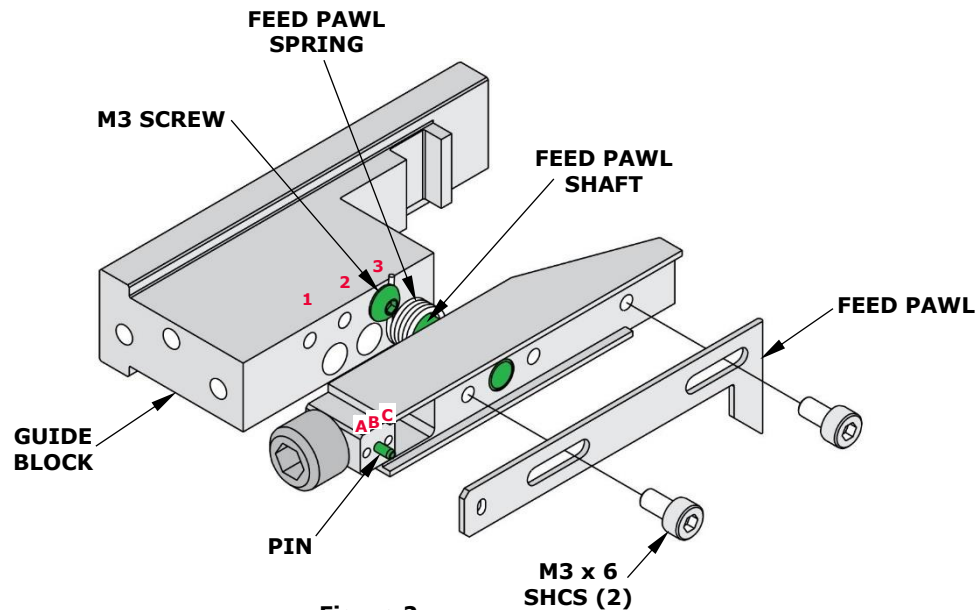

Figure 2

Note: Each applicator is configured and tested by Molex prior to shipping, and the above settings were used to produce the included sample crimps.

Third Dial/Ram Assembly

○ Indicates item number on the Parts List and Assembly Drawing

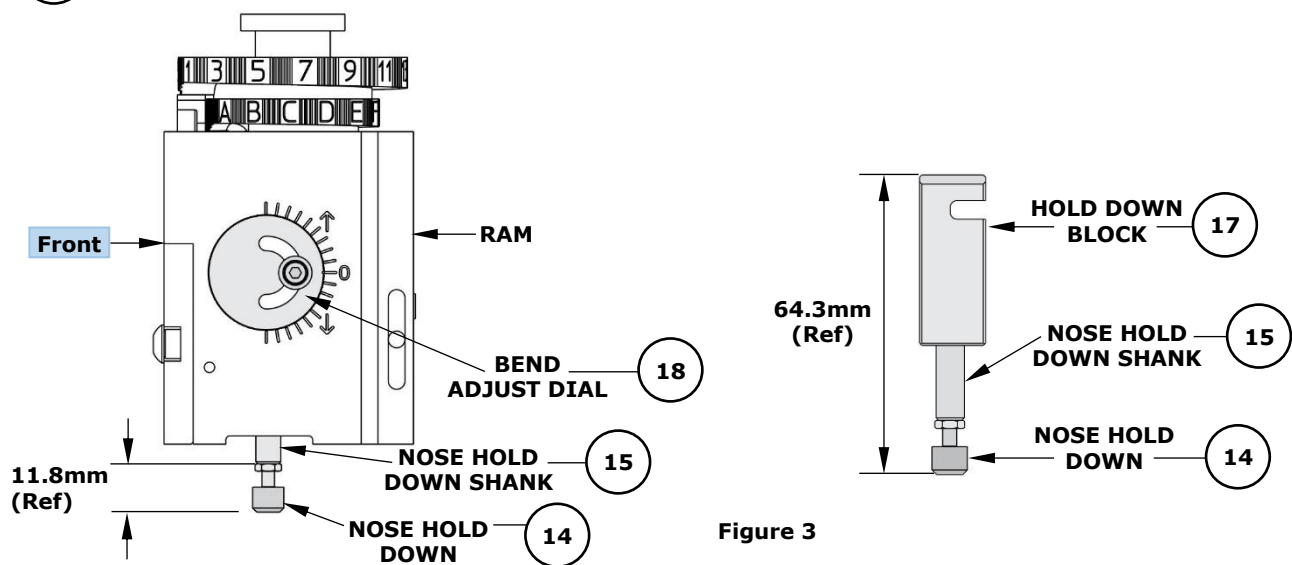

Figure 3

Note: The above dimensions were measured during setup and are included as a reference only. Additional adjustments may be required before crimping for production.

Mounting Datum Location

This applicator was assembled and tested by Molex with the mounting datum in the location shown in Figure 4. Do not remove the mounting datum.

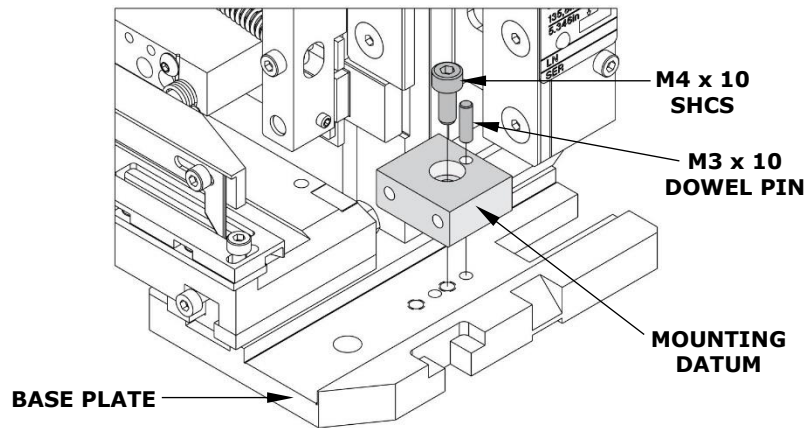

Figure 4

Terminal Guide Position

The terminal guide on this applicator should be positioned so that it is in front of the terminal conductor grips, as shown in Figure 5.

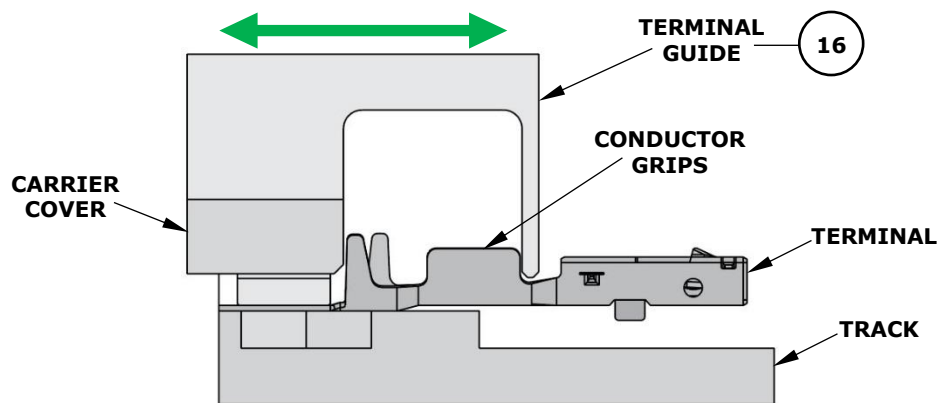

Figure 5

Application Tooling Support

Phone: (402) 458-TOOL (8665)
E-Mail: applicationtooling@molex.com
Website: www.molex.com/applicationtooling

Molex is a registered trademark of Molex, LLC in the United States of America and may be registered in other countries; all other trademarks listed herein belong to their respective owners.