

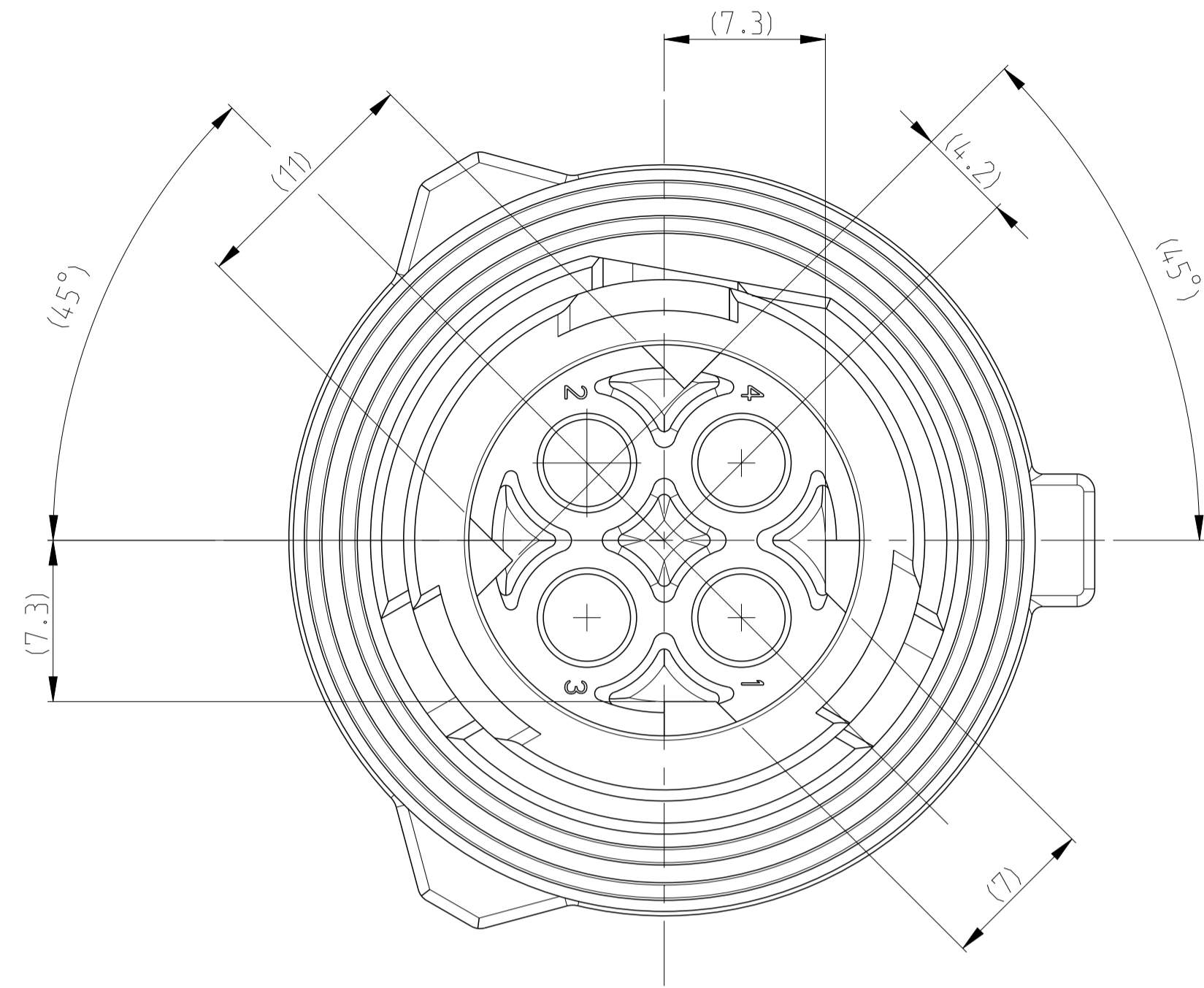

DB CODING 1  
Kodierung 1

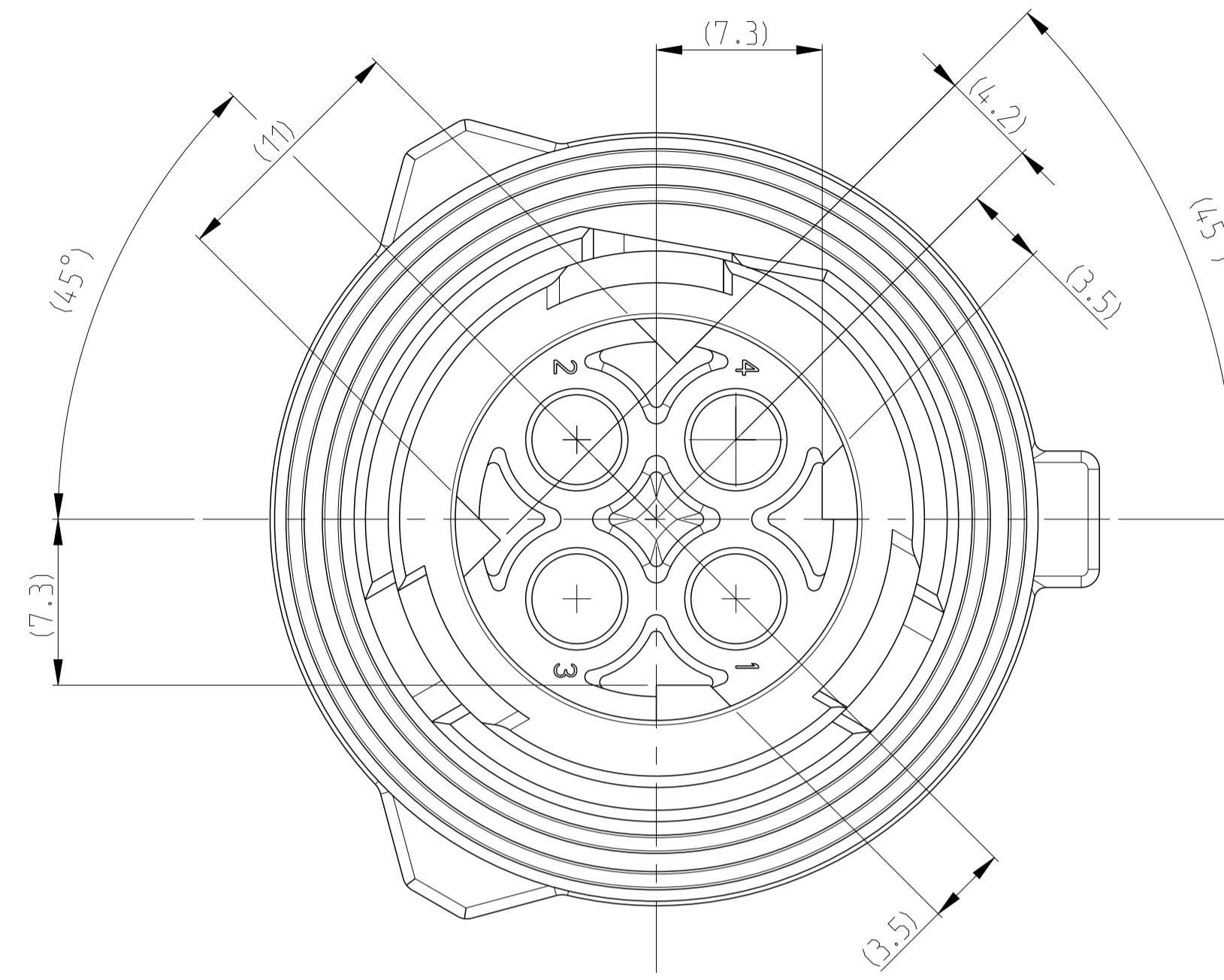

DB CODING 2  
Kodierung 2



DB CODING 3  
Kodierung 3

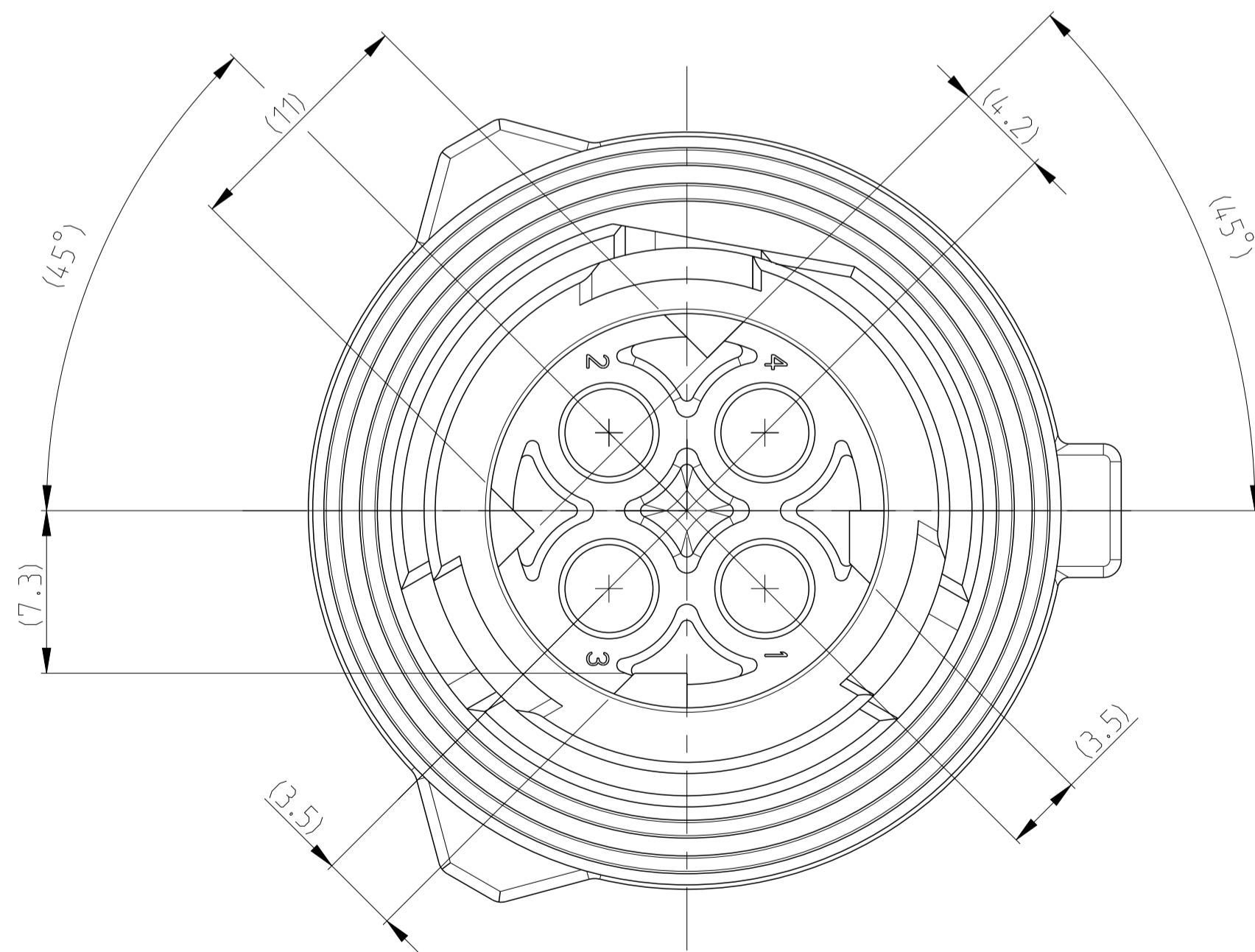

DB CODING 4  
Kodierung 4

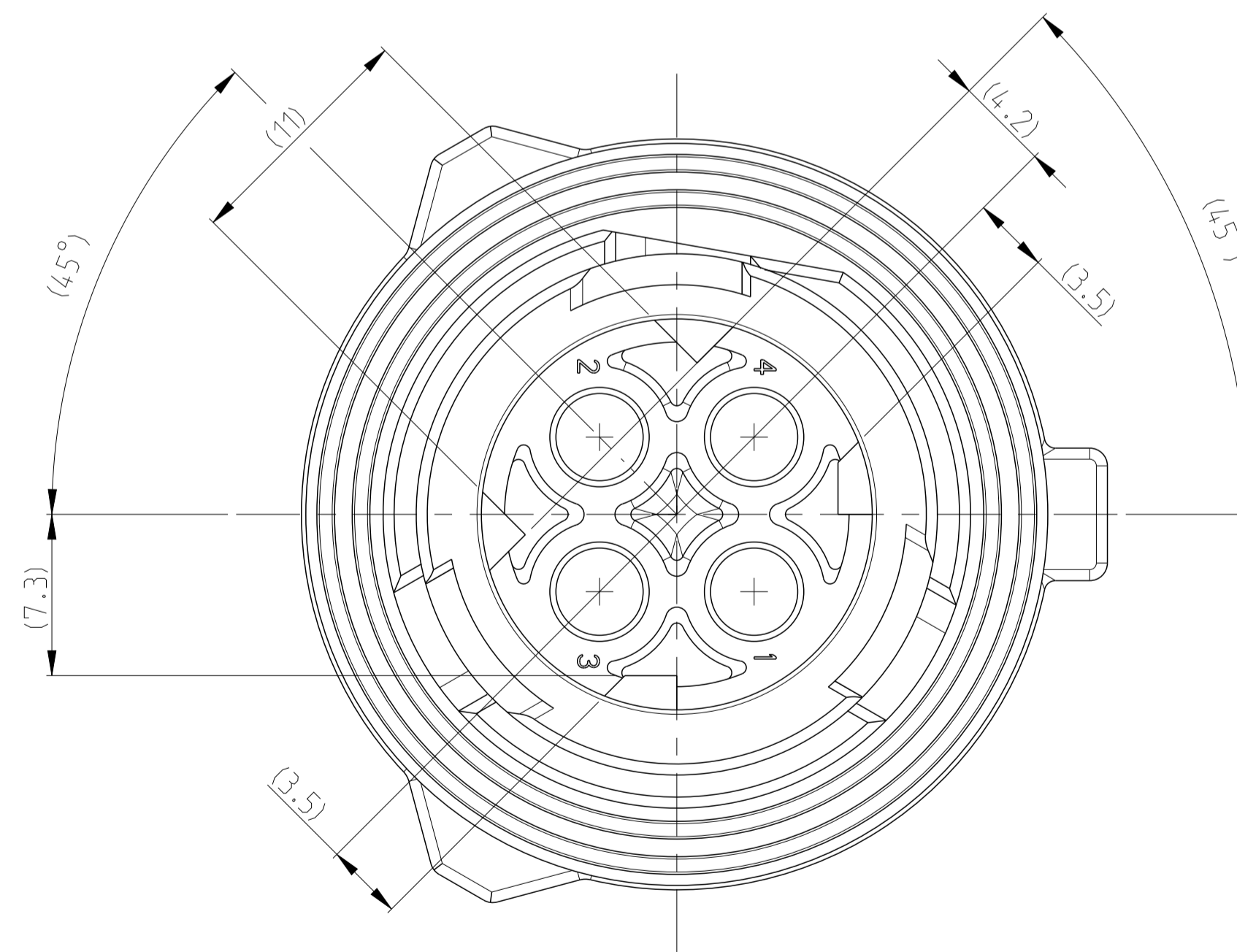

REVISIONS				
P.	LTN	DESCRIPTION	DATE	APVD
-		SEE SHEET 1	-	-

THIS DRAWING IS A CONTROLLED DOCUMENT.		DWN J. Gratzdow	06MAR1995	
DIMENSIONS: mm		CHK J. Haas	06MAR1995	
TOLERANCES UNLESS OTHERWISE SPECIFIED:		APVD Eberwein	10MAY2010	NAME 2.5MM PIN HOUSING, 2-4POS., ASSY 2.5mm Stiftstecker, 2-4pol., Assy
0 PLC ±0.2mm		PRODUCT SPEC	108-18621-0	APPLICATION SPEC
1 PLC ±		APPLIC. SPEC	114-18255-0	RESTRICTED TO
2 PLC ±		WEIGHT	15g	
3 PLC ±		MATERIAL	SEE TABLE	
4 PLC ±		FINISH	SEE TABLE	
ANGLES ±		CUSTOMER DRAWING		
SCALE 5:1		SHEET 2 OF 2	REV D8	