

Ultra Low Phase Noise Amplifier

2 - 18 GHz



MAAL-011151
Rev. V2

Features

- Wideband Performance
- Noise Figure: 3.5 dB @ 10 GHz
- Phase Noise: -165 dBc/Hz @ 100 kHz Offset
- Bias Voltage: 5 V
- Bias Current: 60 mA
- 50 Ω Matched Input / Output
- Positive Voltage Only
- Lead-Free 5 mm 32-lead PQFN Package
- RoHS* Compliant

Applications

- Test & Measurement, EW, ECM, and Radar

Description

The MAAL-011151 is an easy to use, wideband low noise distributed amplifier in a lead-free 5 mm 32-lead PQFN package. It operates from 2 to 18 GHz and provides 15 dB of linear gain, 19 dBm of P1dB, and 3.5 dB of noise figure at 10 GHz. The input and output are fully matched to 50 Ω with typical return loss >10 dB.

The RF input and RF output ports are DC blocked. Amplifier control is available through the use of a control circuit.

This product is fabricated using a low phase noise HBT process which features full passivation for enhanced reliability.

The MAAL-011151 can be used as a low noise amplifier stage for signal generation applications. This device is ideally suited for Test and Measurement, EW, ECM, and Radar applications where ultra low phase noise and drive power is required.

Ordering Information^{1,2}

Part Number	Package
MAAL-011151-TR0100	100 piece reel
MAAL-011151-001SMB	Sample Board

1. Reference Application Note M513 for reel size information.
2. All sample boards include 3 loose parts.

Functional Schematic

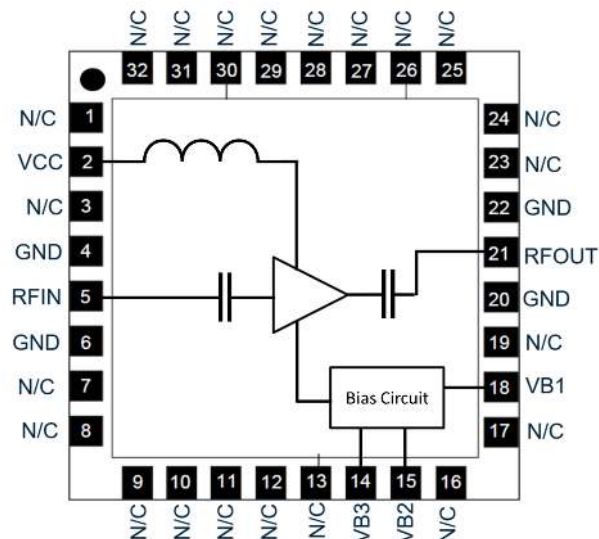

Pin Configuration

Pin #	Pin Name	Description
1,3,7-13,16,17,19,23-32	N/C	No Connection
2	VCC	Collector Voltage
4,6,20,22	GND	Ground
5	RFIN	RF Input
14	VB3	Bias Voltage 3
15	VB2	Bias Voltage 2
18	VB1	Bias Voltage 1
21	RFOUT	RF Output
Paddle ³	GND	Ground

3. The exposed pad centered on the package bottom must be connected to RF, DC and thermal ground.

* Restrictions on Hazardous Substances, compliant to current RoHS EU directive.

Ultra Low Phase Noise Amplifier

2 - 18 GHz



MAAL-011151

Rev. V2

Electrical Specifications: $T_A = +25^\circ\text{C}$, $V_{CC} = V_{CT}^4 = 5\text{ V}$, $Z_0 = 50\ \Omega$

Parameter	Test Conditions	Units	Min.	Typ.	Max.
Gain	$P_{IN} = -15\text{ dBm}$ 2 GHz 10 GHz 18 GHz	dB	15.0 14.0 13.5	16 15 15	—
Output P3dB ⁵	2 GHz 10 GHz 18 GHz	dBm	—	22 20 16	—
Output Power	$P_{IN} = +5.7\text{ dBm}$, 2 GHz $P_{IN} = +3.0\text{ dBm}$, 10 GHz $P_{IN} = -4.0\text{ dBm}$, 18 GHz	dBm	18.0 15.0 9.0	20 19 13	—
Input Return Loss	$P_{IN} = -15\text{ dBm}$	dB	—	10	—
Output Return Loss	$P_{IN} = -15\text{ dBm}$	dB	—	10	—
Noise Figure	2 GHz 10 GHz 18 GHz	dB	—	7.0 3.5 8.0	—
Isolation	$P_{IN} = -15\text{ dBm}$ 2 GHz 10 GHz 18 GHz	dB	—	48 42 33	—
Phase Noise	$P_{IN} = +3\text{ dBm}$, 12 GHz 100 Hz 1 kHz 10 kHz 100 kHz	dBc/Hz	—	-143 -149 -158 -165	—
ICQ	—	mA	—	60	—
ICT ⁴	Total current into R1, R2	mA	—	2	—

4. Reference detailed bias conditions on page 3.

5. MACOM does not recommend sustained operation at power levels above 3 dB compression.

Maximum Operating Conditions

Parameter	Rating
Input Power	$P_{IN} < 3\text{ dB}$ Compression Point
ICQ	90 mA
Junction Temperature ^{6,7}	130°C
Operating Temperature	-40°C to +85°C

6. Operating at nominal conditions with junction temperature $\leq 130^\circ\text{C}$ will ensure $\text{MTTF} > 1 \times 10^6$ hours.

7. Junction Temperature (T_J) = $T_C + \Theta_{JC} * ((V * I) - (P_{OUT} - P_{IN}))$.
Typical thermal resistance (Θ_{JC}) = 120°C/W.

a) For $T_C = +25^\circ\text{C}$

$T_J = +72^\circ\text{C}$ @ 5 V, 98 mA, $P_{OUT} = 20\text{ dBm}$, $P_{IN} = 4.5\text{ dBm}$

b) For $T_C = +85^\circ\text{C}$

$T_J = 129^\circ\text{C}$ @ 5 V, 88 mA, $P_{OUT} = 19\text{ dBm}$, $P_{IN} = 4.5\text{ dBm}$

Absolute Maximum Ratings^{8,9}

Parameter	Absolute Maximum
Input Power	12 dBm
ICQ	120 mA
VCC, VB1, VB2, VB3	6 V
VB1, VB2, VB3, Current	5 mA
Junction Temperature ¹⁰	150°C
Storage Temperature	-65°C to +125°C

8. Exceeding any one or combination of these limits may cause permanent damage to this device.

9. MACOM does not recommend sustained operation near these survivability limits.

10. Junction temperature directly effects device MTTF. Junction temperature should be kept as low as possible to maximize lifetime.

Application Schematic

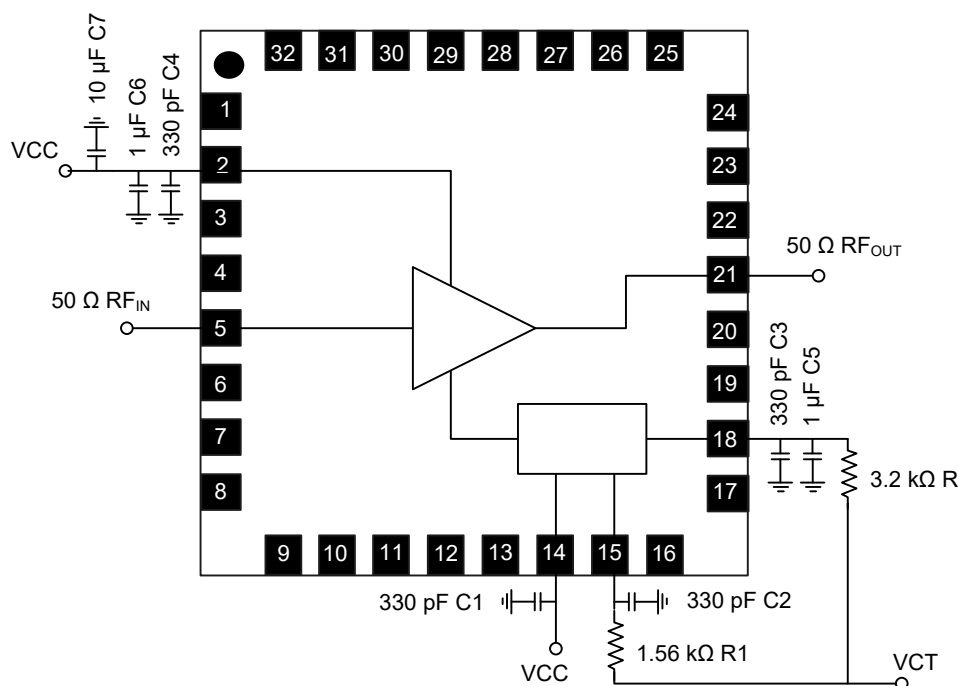

Operating Conditions

Recommended biasing conditions are $V_{CC} = 5\text{ V}$ applied to pin 14 (VB3) and pin 2 (VCC). Apply amplifier control (VCT) through the offset resistors (R1, R2) to pin 15 (VB2) and pin 18 (VB1) according to the application schematic shown. Setting $V_{CT} = 5\text{ V}$ will turn on the amplifier ($I_{CQ} \sim 60\text{ mA}$ from $V_{CC} = 5\text{ V}$). Setting $V_{CT} = 0\text{ V}$ will turn off the amplifier. VB1 and VB2 will draw $< 2\text{ mA}$ (I_{CT}) from $V_{CT} = 5\text{ V}$. All DC supplies need to be low noise to prevent degradation of the amplifier phase noise.

Parts List

Part #	Value	Case Style
C1 - C4	330 pF	Single Layer
C5, C6	1 µF	0402
C7	10 µF	1210
R1	1.56 kΩ	Thin film
R2	3.2 kΩ	Thin film

Ultra Low Phase Noise Amplifier 2 - 18 GHz



MAAL-011151
Rev. V2

Typical Performance Curves: 5 V, ICQ = 60 mA

Gain

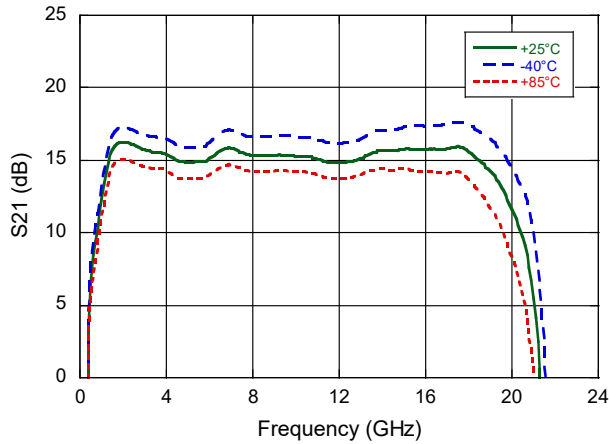

Noise Figure

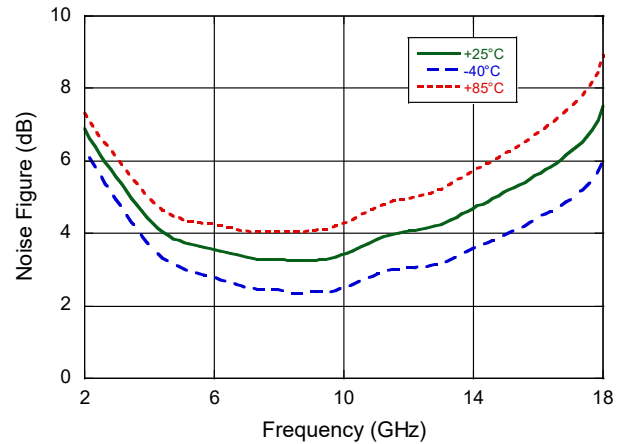

Input Return Loss

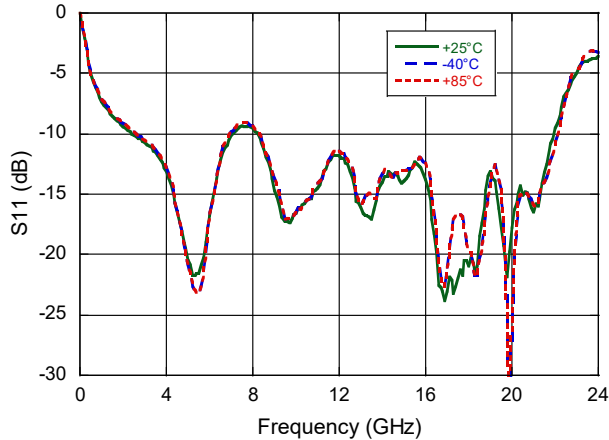

Output Return Loss

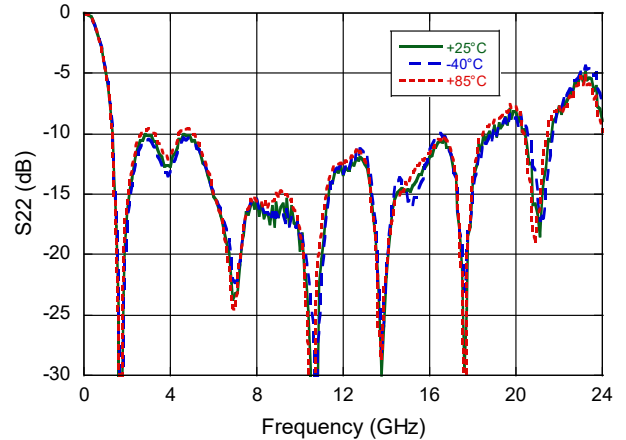

Ultra Low Phase Noise Amplifier 2 - 18 GHz



MAAL-011151
Rev. V2

Typical Performance Curves: 5 V, ICQ = 60 mA

Phase Noise @ +25°C, 12 GHz

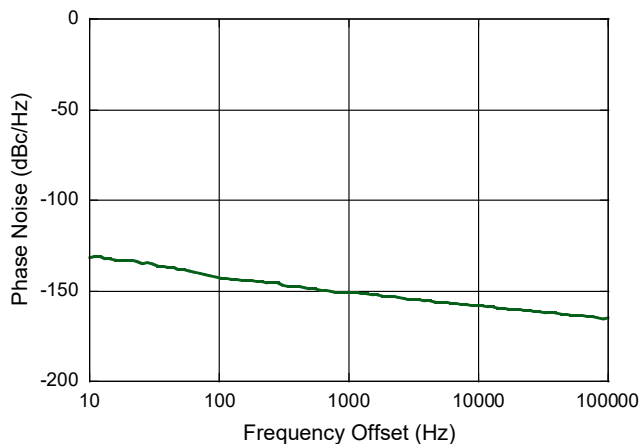

Output IP3 @ +25°C

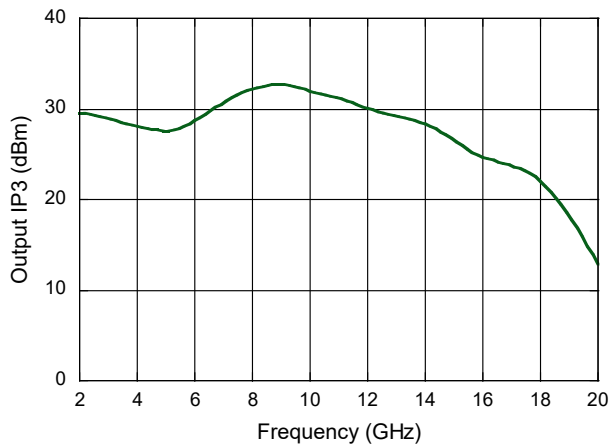

Output Power @ P1dB

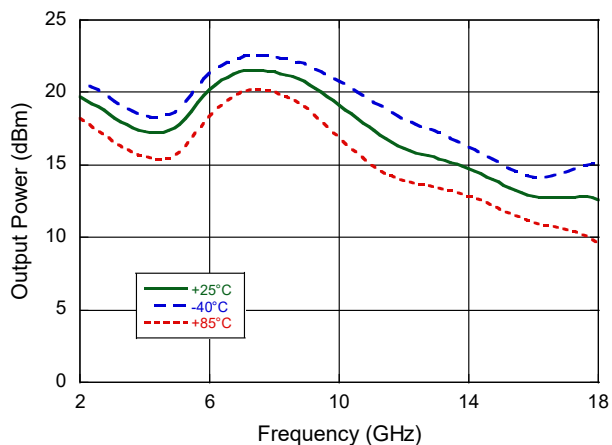

Output Power @ P3dB

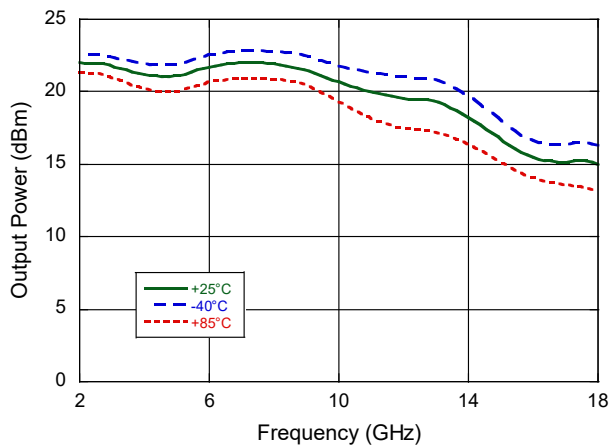

Ultra Low Phase Noise Amplifier

2 - 18 GHz



MAAL-011151
Rev. V2

Handling Procedures

Please observe the following precautions to avoid damage:

Static Sensitivity

These electronic devices are sensitive to electrostatic discharge (ESD) and can be damaged by static electricity. Proper ESD control techniques should be used when handling these HBM Class 1A devices.

Lead-Free 5 mm 32-Lead PQFN Package†

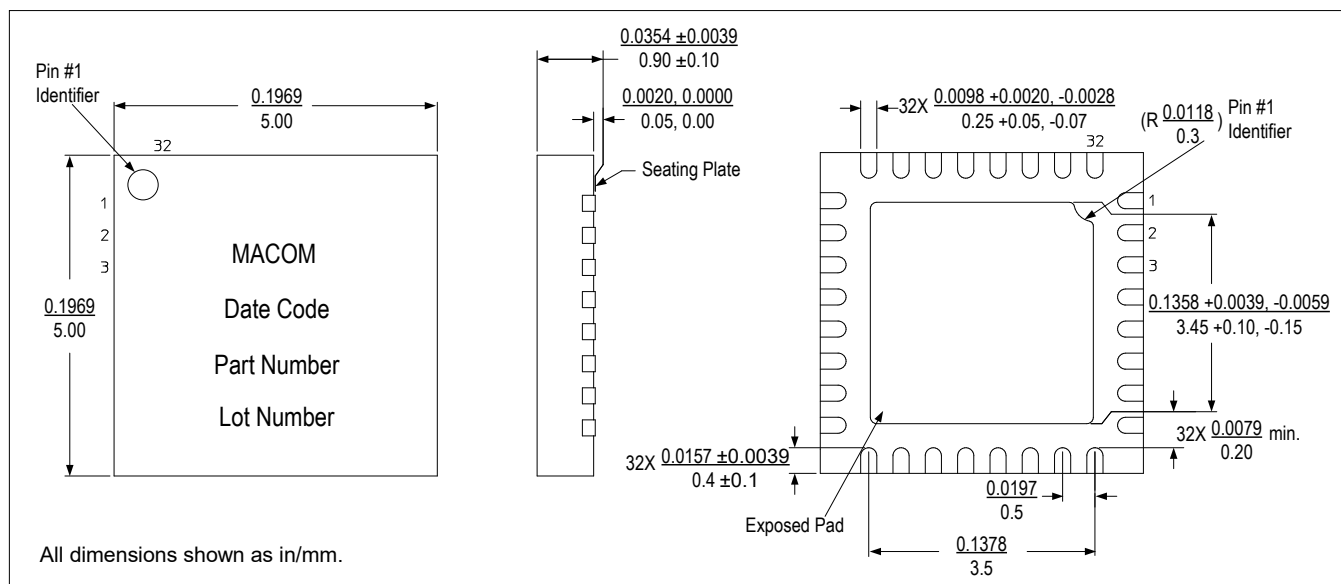

† Reference Application Note S2083 for lead-free solder reflow recommendations.
Meets JEDEC moisture sensitivity level 1 requirements.
Plating is NiPdAuAg.

Ultra Low Phase Noise Amplifier

2 - 18 GHz



MAAL-011151
Rev. V2

MACOM Technology Solutions Inc. ("MACOM"). All rights reserved.

These materials are provided in connection with MACOM's products as a service to its customers and may be used for informational purposes only. Except as provided in its Terms and Conditions of Sale or any separate agreement, MACOM assumes no liability or responsibility whatsoever, including for (i) errors or omissions in these materials; (ii) failure to update these materials; or (iii) conflicts or incompatibilities arising from future changes to specifications and product descriptions, which MACOM may make at any time, without notice. These materials grant no license, express or implied, to any intellectual property rights.

THESE MATERIALS ARE PROVIDED "AS IS" WITH NO WARRANTY OR LIABILITY, EXPRESS OR IMPLIED, RELATING TO SALE AND/OR USE OF MACOM PRODUCTS INCLUDING FITNESS FOR A PARTICULAR PURPOSE, MERCHANTABILITY, INFRINGEMENT OF INTELLECTUAL PROPERTY RIGHT, ACCURACY OR COMPLETENESS, OR SPECIAL, INDIRECT, INCIDENTAL, OR CONSEQUENTIAL DAMAGES WHICH MAY RESULT FROM USE OF THESE MATERIALS.

MACOM products are not intended for use in medical, lifesaving or life sustaining applications. MACOM customers using or selling MACOM products for use in such applications do so at their own risk and agree to fully indemnify MACOM for any damages resulting from such improper use or sale.