

⊕ ⊕ .015 ⊕ TAIL TO TAIL  
 ⊕ ⊕ .020 ⊕ X ⊕ Y ⊕ TAIL TO INSULATOR

**OPTION "A" ASSEMBLY**  
 STANDARD HOUSING

NOTE FOR LEAD FREE CONVERSION:  
 THE PRIMARY SHIPPING CARTON WILL BE LABELED "COMPLIANT TO ROHS DIRECTIVE 2002/95/EC AND ELV ANNEX II OF DIRECTIVE 2000/53/EC". CARTONS WITHOUT THIS LABEL MAY CONTAIN PRODUCT WITH LEAD.

- NOTES:**
- 1.) MATERIAL -  
 INSULATOR - LCP, UL 94V-0, COLOR BLACK  
 CONTACTS - PHOSPHOR BRONZE
  - 2.) SEE SHT. 5 & 6 FOR CHART DIMENSIONS AND EDP NO.'S
  - 3.) RECOMMENDED MATING PIN LENGTH:  
 LOWER ROW - .200" MIN., .285" MAX.  
 UPPER ROW - .200" MIN.
  - 4.) REFER TO PRODUCT SPECIFICATION PS-71973-9999 FOR PERFORMANCE DATA
  - 5.) MANUFACTURED DATE CODE - YEAR, WEEK.
  - 6.) PACKAGING: FOR THIS PRODUCT IN TUBES SEE SHT. 6 & 7  
 FOR THIS PRODUCT IN TRAYS SEE SHT. 8 & 9

**FINISHES**

- 15 GOLD .000015 MINIMUM GOLD PLATE IN SELECT AREA OVER  
 .000050 MINIMUM NICKEL UNDERPLATE OVER-ALL WITH  
 .000075 MINIMUM TIN PLATE IN SELECT AREA.
- 30 GOLD .000030 MINIMUM GOLD PLATE IN SELECT AREA OVER  
 .000050 MINIMUM NICKEL UNDERPLATE OVER-ALL WITH  
 .000075 MINIMUM TIN PLATE IN SELECT AREA.
- 50 GOLD .000050 MINIMUM GOLD PLATE IN SELECT AREA OVER  
 .000050 MINIMUM NICKEL UNDERPLATE OVER-ALL WITH  
 .000100 MINIMUM TIN PLATE IN SELECT AREA.

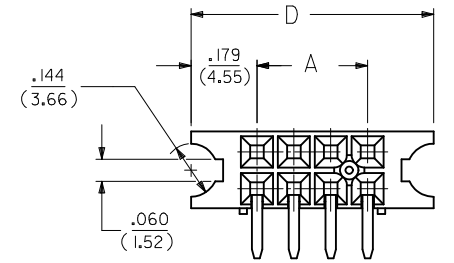
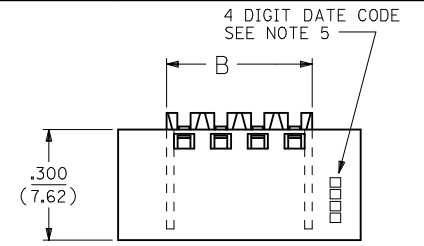
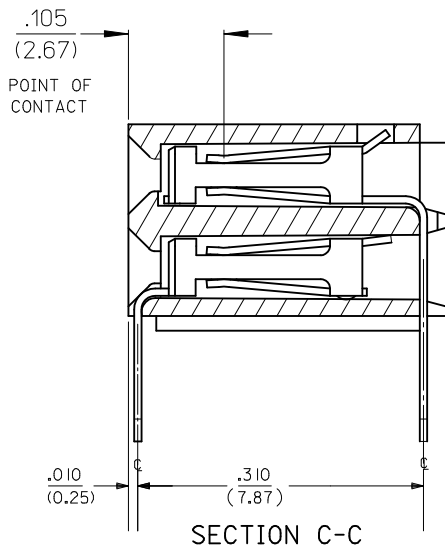

**OPTION "B" ASSEMBLY**

STD. HOUSING W/MOUNTING EARS  
 SCALE 4:1  
 REFER TO OPT. A FOR ALL OTHER INFORMATION

**OPTION "J" ASSEMBLY**  
 OPTION "J" IS THE SAME AS OPTION "B" EXCEPT  
 DATE CODE IS NOT STAMPED ON HOUSING.

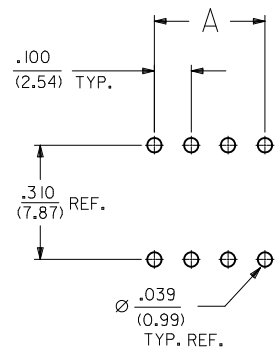

**RECOMMENDED P.C.B. LAYOUT**

ADD OPTION K & L EC NO: S2010-0534 DRWN:SKANG 2009/12/30 CHKD:ATSEE 2010/01/08 APPR:MLONG 2010/01/14	QUALITY SYMBOLS $F_A = 0$ $F_E = 0$ $F_P = 0$	GENERAL TOLERANCES (UNLESS SPECIFIED)		DIMENSION STYLE IN/MM		SCALE NTS		DESIGN UNITS INCH		THIRD ANGLE PROJECTION																		
		<table border="1"> <thead> <tr> <th></th> <th>mm</th> <th>INCH</th> </tr> </thead> <tbody> <tr> <td>4 PLACES</td> <td>± ---</td> <td>± ---</td> </tr> <tr> <td>3 PLACES</td> <td>± ---</td> <td>± .010</td> </tr> <tr> <td>2 PLACES</td> <td>± 0.25</td> <td>± ---</td> </tr> <tr> <td>1 PLACE</td> <td>± ---</td> <td>± ---</td> </tr> </tbody> </table>			mm	INCH	4 PLACES	± ---	± ---	3 PLACES	± ---	± .010	2 PLACES	± 0.25	± ---	1 PLACE	± ---	± ---	DRAWN BY DJB		DATE 1991/10/21		TITLE EARLY ENTRY R/A RECPT .120"PC TAIL W/O LOWER ROW PINSTOP-.100" GRID		MOLEX INCORPORATED		SHEET NO. 1 OF 26	
			mm	INCH																								
		4 PLACES	± ---	± ---																								
3 PLACES	± ---	± .010																										
2 PLACES	± 0.25	± ---																										
1 PLACE	± ---	± ---																										
ANGULAR ± 1/2°		CHECKED BY DJB		DATE 1991/10/21		APPROVED BY MLONG		DATE 2010/01/14		DOCUMENT NO. SDA-71973-****																		
DRAFT WHERE APPLICABLE MUST REMAIN WITHIN DIMENSIONS		SEE TABLE		MATERIAL NO.		SIZE A3		THIS DRAWING CONTAINS INFORMATION THAT IS PROPRIETARY TO MOLEX INCORPORATED AND SHOULD NOT BE USED WITHOUT WRITTEN PERMISSION																				

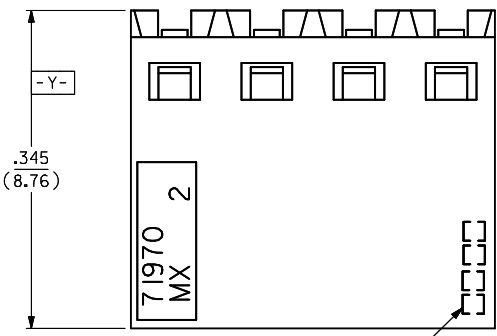

- NOTES:**
- MATERIAL-  
INSULATOR - LCP, UL 94V-0, COLOR BLACK  
CONTACTS - PHOSPHOR BRONZE
  - SEE SHT. 9 & 10 FOR CHART DIMENSIONS AND EDP NO.'S
  - RECOMMENDED MATING PIN LENGTH:  
LOWER ROW - .200" MIN., .285" MAX.  
UPPER ROW - .200" MIN.
  - REFER TO PRODUCT SPECIFICATION PS-71973-9999 FOR PERFORMANCE DATA
  - MANUFACTURED DATE CODE - YEAR, WEEK.
  - PACKAGING: FOR THIS PRODUCT IN TUBES SEE SHT. 10 & 11  
FOR THIS PRODUCT IN TRAYS SEE SHT. 12 & 13

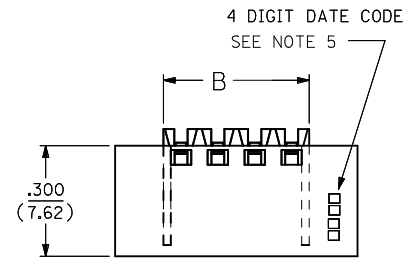

4 DIGIT DATE CODE  
SEE NOTE 5

**FINISHES**

- 15 GOLD .000015 MINIMUM GOLD PLATE IN SELECT AREA OVER  
.000050 MINIMUM NICKEL UNDERPLATE OVER-ALL WITH  
.000075 MINIMUM TIN PLATE IN SELECT AREA.
- 30 GOLD .000030 MINIMUM GOLD PLATE IN SELECT AREA OVER  
.000050 MINIMUM NICKEL UNDERPLATE OVER-ALL WITH  
.000075 MINIMUM TIN PLATE IN SELECT AREA.
- 50 GOLD .000050 MINIMUM GOLD PLATE IN SELECT AREA OVER  
.000050 MINIMUM NICKEL UNDERPLATE OVER-ALL WITH  
.000100 MINIMUM TIN PLATE IN SELECT AREA.

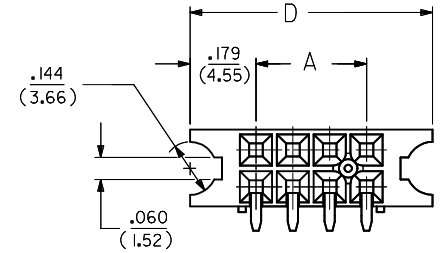

**OPTION "D" ASSEMBLY**  
STD. HOUSING W/MOUNTING EARS  
SCALE 4:1

REFER TO OPT. C FOR ALL OTHER INFORMATION

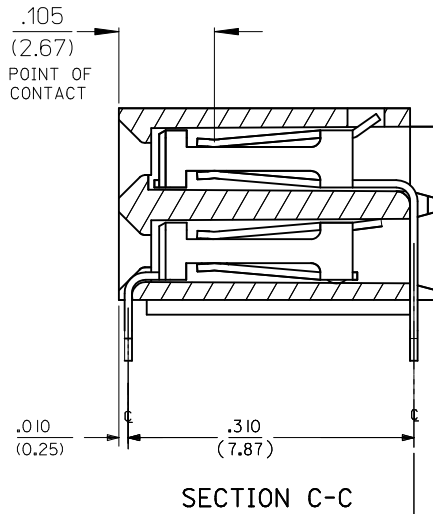
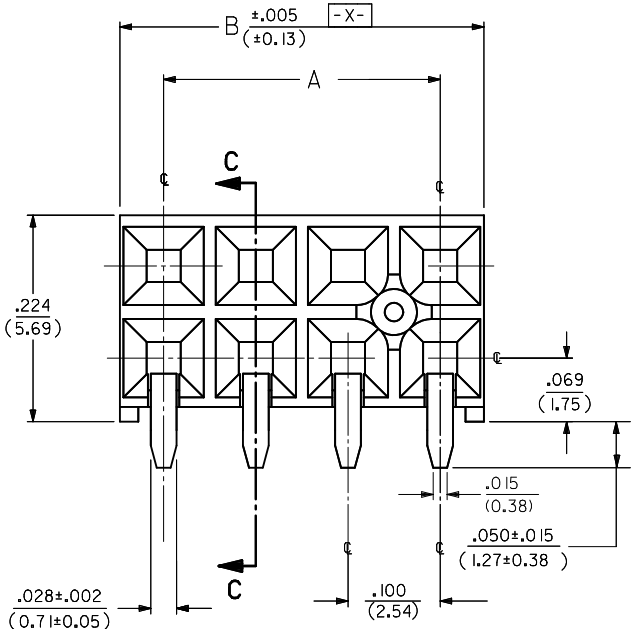

**SECTION C-C**

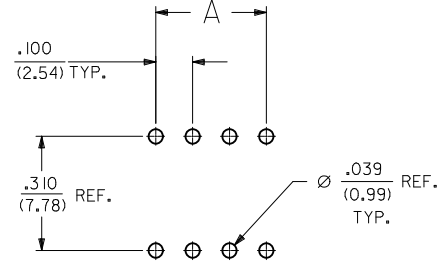

**RECOMMENDED P.C.B. LAYOUT**

- ⊕ ∅ .015 (S) TAIL TO TAIL
- ⊕ ∅ .020 (S) X (Y) TAIL TO INSULATOR

**OPTION "C" ASSEMBLY**  
STANDARD HOUSING

**NOTE FOR LEAD FREE CONVERSION:**  
THE PRIMARY SHIPPING CARTON WILL BE LABELED "COMPLIANT TO RoHS DIRECTIVE 2002/95/EC AND ELV ANNEX II OF DIRECTIVE 2000/53/EC". CARTONS WITHOUT THIS LABEL MAY CONTAIN PRODUCT WITH LEAD.

ADD OPTION K & L EC NO: S2010-0534 DRWN:SKANG 2009/12/30 CHKD:ATSEE 2010/01/08 APPR:MLONG 2010/01/14	QUALITY SYMBOLS	GENERAL TOLERANCES (UNLESS SPECIFIED)	DIMENSION STYLE	SCALE	DESIGN UNITS	THIRD ANGLE PROJECTION
	▽ <sub>A</sub> = 0	mm INCH	IN/MM	NTS	INCH	
	▽ <sub>E</sub> = 0	4 PLACES ± --- ± ---	DRAWN BY DATE			
	▽ <sub>F</sub> = 0	3 PLACES ± --- ± .010	CHECKED BY DATE			

4 PLACES ± --- ± ---	DRAWN BY DATE	TITLE
3 PLACES ± --- ± .010	CHECKED BY DATE	
2 PLACES ± 0.25 ± ---	APPROVED BY DATE	
1 PLACE ± --- ± ---	MLONG 2010/01/14	
ANGULAR ± 1/2°	MATERIAL NO.	DOCUMENT NO.
DRAFT WHERE APPLICABLE MUST REMAIN WITHIN DIMENSIONS	SEE TABLE	
	SIZE A3	

1991/10/21	1991/10/21	2010/01/14
EARLY ENTRY R/A RECPT	MOLEX INCORPORATED	SDA-71973-****
.120" PC TAIL W/O LOWER ROW PINSTOP-.100" GRID		

2 OF 26	THIS DRAWING CONTAINS INFORMATION THAT IS PROPRIETARY TO MOLEX INCORPORATED AND SHOULD NOT BE USED WITHOUT WRITTEN PERMISSION
---------	---

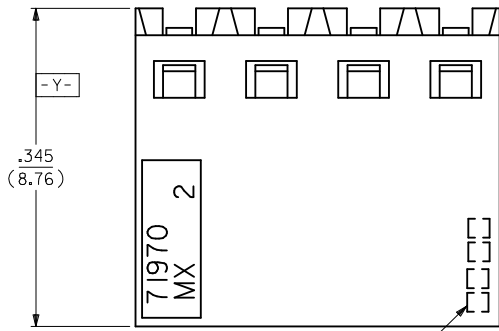

4 DIGIT DATE CODE  
SEE NOTE 5

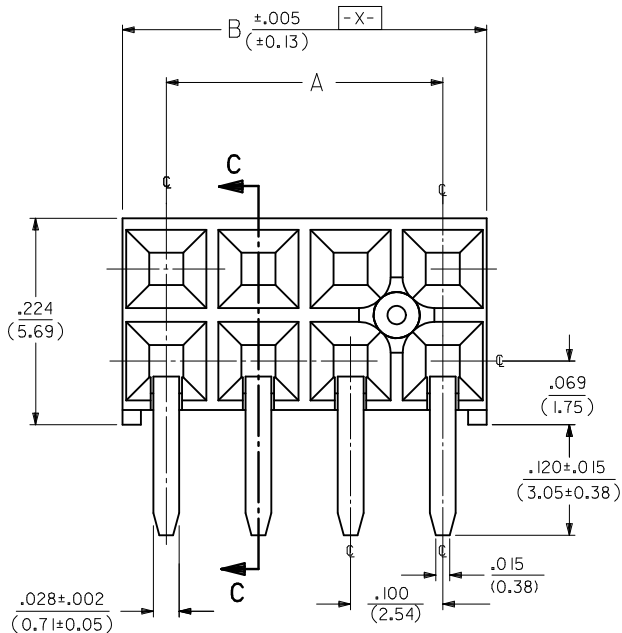

- ⊕ ∅ .015 ⊕ TAIL TO TAIL
- ⊕ ∅ .020 ⊕ X ⊕ Y ⊕ TAIL TO INSULATOR

**OPTION "E" ASSEMBLY**  
STANDARD HOUSING

NOTE FOR LEAD FREE CONVERSION:

THE PRIMARY SHIPPING CARTON WILL BE LABELED "COMPLIANT TO ROHS DIRECTIVE 2002/95/EC AND ELV ANNEX II OF DIRECTIVE 2000/53/EC". CARTONS WITHOUT THIS LABEL MAY CONTAIN PRODUCT WITH LEAD.

- NOTES:**
- 1.) MATERIAL -  
INSULATOR - LCP, UL 94V-0, COLOR BLACK  
CONTACTS - PHOSPHOR BRONZE
  - 2.) SEE SHT. 13 & 14 FOR CHART DIMENSIONS AND EDP NO.'S
  - 3.) RECOMMENDED MATING PIN LENGTH:  
LOWER ROW - .200" MIN., .250" MAX.  
UPPER ROW - .200" MIN.
  - 4.) REFER TO PRODUCT SPECIFICATION PS-71973-9999 FOR PERFORMANCE DATA
  - 5.) MANUFACTURED DATE CODE - YEAR, WEEK.
  - 6.) PACKAGING: FOR THIS PRODUCT IN TUBES SEE SHT. 14 & 15  
FOR THIS PRODUCT IN TRAYS SEE SHT. 16 & 17

**FINISHES**

- 15 GOLD .000015 MINIMUM GOLD PLATE IN SELECT AREA OVER .000050 MINIMUM NICKEL UNDERPLATE OVER-ALL WITH .000075 MINIMUM TIN PLATE IN SELECT AREA.
- 30 GOLD .000030 MINIMUM GOLD PLATE IN SELECT AREA OVER .000050 MINIMUM NICKEL UNDERPLATE OVER-ALL WITH .000075 MINIMUM TIN PLATE IN SELECT AREA.
- 50 GOLD .000050 MINIMUM GOLD PLATE IN SELECT AREA OVER .000050 MINIMUM NICKEL UNDERPLATE OVER-ALL WITH .000100 MINIMUM TIN PLATE IN SELECT AREA.

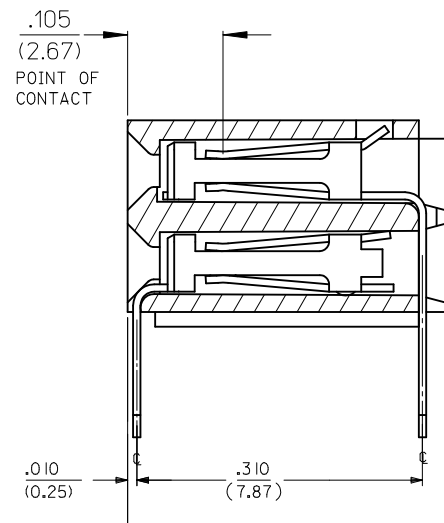

**SECTION C-C**

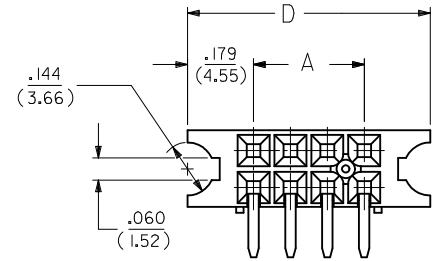
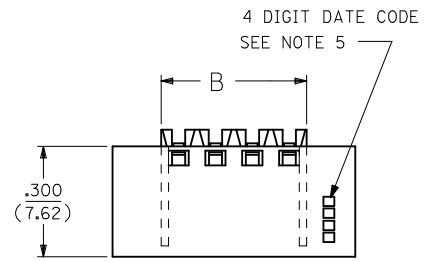

**OPTION "F" ASSEMBLY**  
STD. HOUSING W/MOUNTING EARS  
AND LOWER ROW PINSTOP  
SCALE 4:1

REFER TO OPT. E FOR ALL OTHER INFORMATION

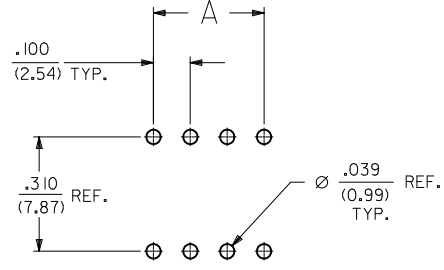

**RECOMMENDED P.C.B. LAYOUT**

ADD OPTION K & L EC NO: S2010-0534 DRWN:SKANG 2009/12/30 CHKD:ATSEE 2010/01/08 APPR:MLONG 2010/01/14	DESCRIPTION REV	QUALITY SYMBOLS	GENERAL TOLERANCES (UNLESS SPECIFIED)		DIMENSION STYLE		SCALE	DESIGN UNITS	THIRD ANGLE PROJECTION		
		$F_A = 0$ $F_C = 0$ $F_P = 0$	mm      INCH 4 PLACES ± --- ± --- 3 PLACES ± --- ± .010 2 PLACES ± 0.25 ± --- 1 PLACE ± --- ± --- ANGULAR ± 1/2°	IN/MM	NTS	INCH	DRAWN BY: DJB      DATE: 1991/10/21 CHECKED BY:      DATE:      1991/10/21 APPROVED BY:      DATE: 2010/01/14 MATERIAL NO.      DOCUMENT NO.		TITLE: EARLY ENTRY R/A RECPT .120" PC TAIL W/O LOWER ROW PINSTOP-.100" GRID MOLEX INCORPORATED		SHEET NO.
		DRAFT WHERE APPLICABLE MUST REMAIN WITHIN DIMENSIONS	SEE TABLE	THIS DRAWING CONTAINS INFORMATION THAT IS PROPRIETARY TO MOLEX INCORPORATED AND SHOULD NOT BE USED WITHOUT WRITTEN PERMISSION		MOLEX INCORPORATED SDA-71973-****		3 OF 26			

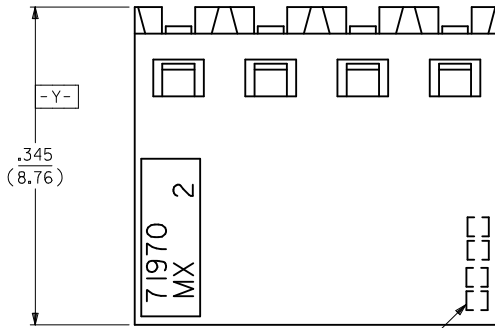

4 DIGIT DATE CODE  
SEE NOTE 5

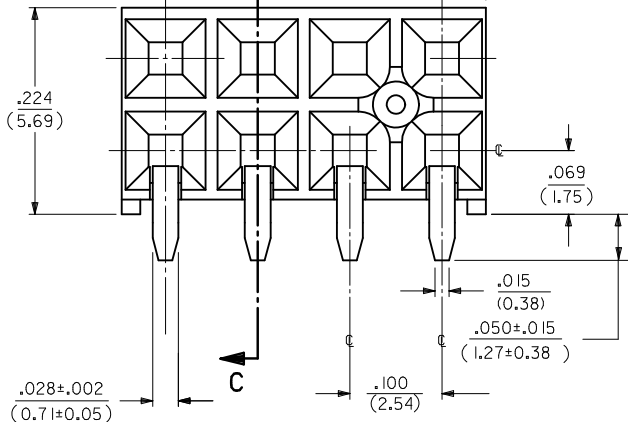
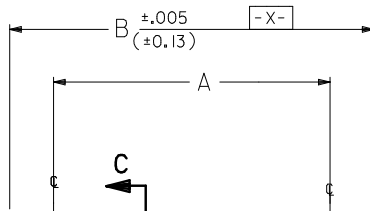

⊕ ∅ .015 ⊕ TAIL TO TAIL  
⊕ ∅ .020 ⊕ X ⊕ Y ⊕ TAIL TO INSULATOR

**OPTION "G" ASSEMBLY**  
STANDARD HOUSING

NOTE FOR LEAD FREE CONVERSION:

THE PRIMARY SHIPPING CARTON WILL BE LABELED \*COMPLIANT TO RoHS DIRECTIVE 2002/95/EC AND ELV ANNEX II OF DIRECTIVE 2000/53/EC\*. CARTONS WITHOUT THIS LABEL MAY CONTAIN PRODUCT WITH LEAD.

- NOTES:**
- MATERIAL -  
INSULATOR - LCP, UL 94V-0, COLOR BLACK  
CONTACTS - PHOSPHOR BRONZE
  - SEE SHT. 17 & 18 FOR CHART DIMENSIONS AND EDP NO.'S
  - RECOMMENDED MATING PIN LENGTH:  
LOWER ROW - .200" MIN., .250" MAX.  
UPPER ROW - .200" MIN.
  - REFER TO PRODUCT SPECIFICATION PS-71973-9999 FOR PERFORMANCE DATA
  - MANUFACTURED DATE CODE - YEAR, WEEK.
  - PACKAGING: FOR THIS PRODUCT IN TUBES SEE SHT. 18 & 19  
FOR THIS PRODUCT IN TRAYS SEE SHT. 20 & 21

**FINISHES**

- 15 GOLD .000015 MINIMUM GOLD PLATE IN SELECT AREA OVER .000050 MINIMUM NICKEL UNDERPLATE OVER-ALL WITH .000075 MINIMUM TIN PLATE IN SELECT AREA.
- 30 GOLD .000030 MINIMUM GOLD PLATE IN SELECT AREA OVER .000050 MINIMUM NICKEL UNDERPLATE OVER-ALL WITH .000075 MINIMUM TIN PLATE IN SELECT AREA.
- 50 GOLD .000050 MINIMUM GOLD PLATE IN SELECT AREA OVER .000050 MINIMUM NICKEL UNDERPLATE OVER-ALL WITH .000100 MINIMUM TIN PLATE IN SELECT AREA.

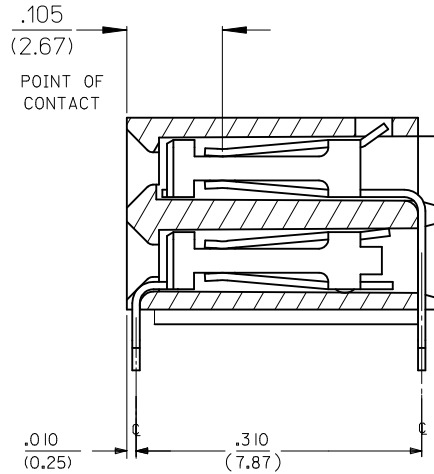

**SECTION C-C**

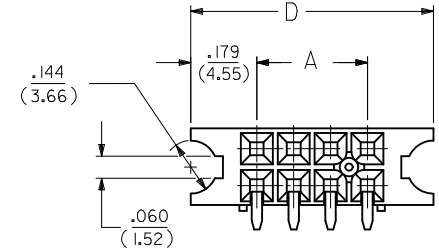
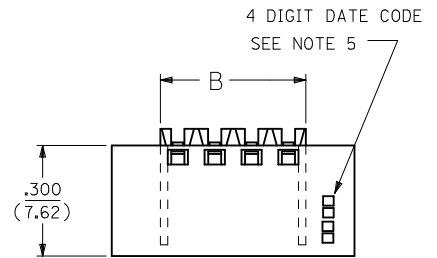

**OPTION "H" ASSEMBLY**  
STD. HOUSING W/MOUNTING EARS  
AND LOWER PINSTOP  
SCALE 4:1

REFER TO OPT. G FOR ALL OTHER INFORMATION

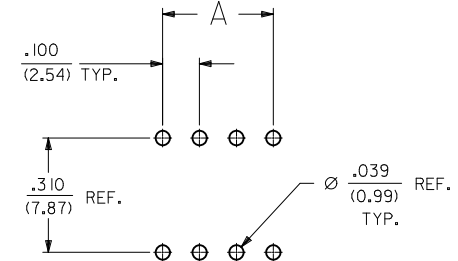

**RECOMMENDED P.C.B. LAYOUT**

<b>ADD OPTION K &amp; L</b> EC NO: S2010-0534 DRWN:SKANG 2009/12/30 CHKD:ATSEE 2010/01/08 APPR:MLONG 2010/01/14	QUALITY SYMBOLS $F_A = 0$ $F_G = 0$ $F_P = 0$	GENERAL TOLERANCES (UNLESS SPECIFIED)		DIMENSION STYLE <b>IN/MM</b>		SCALE NTS	DESIGN UNITS INCH	THIRD ANGLE PROJECTION	
		4 PLACES ± --- ± ---	3 PLACES ± --- ± .010	DRAWN BY DJB	DATE 1991/10/21	TITLE <b>EARLY ENTRY R/A RECPT .120"PC TAIL W/O LOWER ROW PINSTOP-.100" GRID</b>			
		2 PLACES ± 0.25 ± ---	1 PLACE ± --- ± ---	CHECKED BY DJB	DATE 1991/10/21	MOLEX INCORPORATED			
		ANGULAR ± 1/2°		APPROVED BY MLONG	DATE 2010/01/14	MATERIAL NO. SEE TABLE	DOCUMENT NO. SDA-71973-****	SHEET NO. 4 OF 26	
DRAFT WHERE APPLICABLE MUST REMAIN WITHIN DIMENSIONS		SIZE A3		THIS DRAWING CONTAINS INFORMATION THAT IS PROPRIETARY TO MOLEX INCORPORATED AND SHOULD NOT BE USED WITHOUT WRITTEN PERMISSION					

10 9 8 7 6 5 4 3 2 1

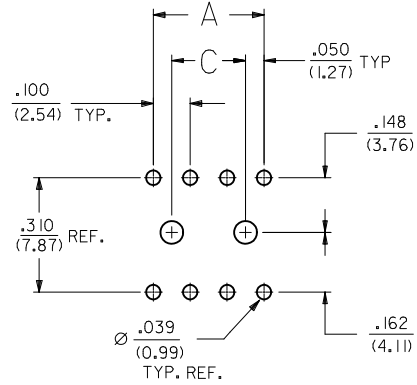
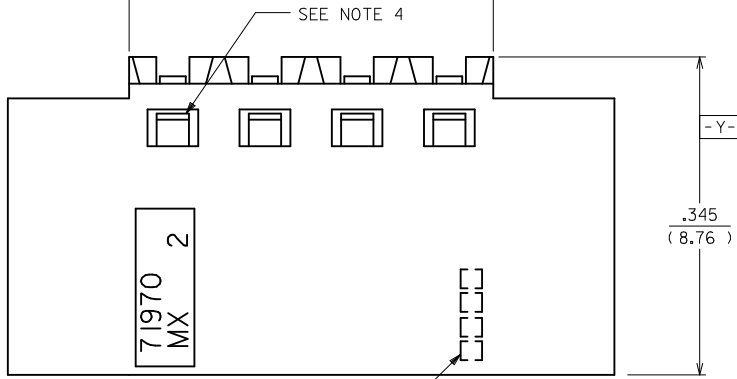

FINISHES PER ES-88-(\*\*\*)

- 15 GOLD .000015 MINIMUM GOLD PLATE IN SELECT AREA OVER .000050 MINIMUM NICKEL UNDERPLATE OVER-ALL WITH .000075 MINIMUM TIN PLATE IN SELECT AREA.
- 30 GOLD .000030 MINIMUM GOLD PLATE IN SELECT AREA OVER .000050 MINIMUM NICKEL UNDERPLATE OVER-ALL WITH .000075 MINIMUM TIN PLATE IN SELECT AREA.
- 50 GOLD .000050 MINIMUM GOLD PLATE IN SELECT AREA OVER .000050 MINIMUM NICKEL UNDERPLATE OVER-ALL WITH .000100 MINIMUM TIN PLATE IN SELECT AREA.

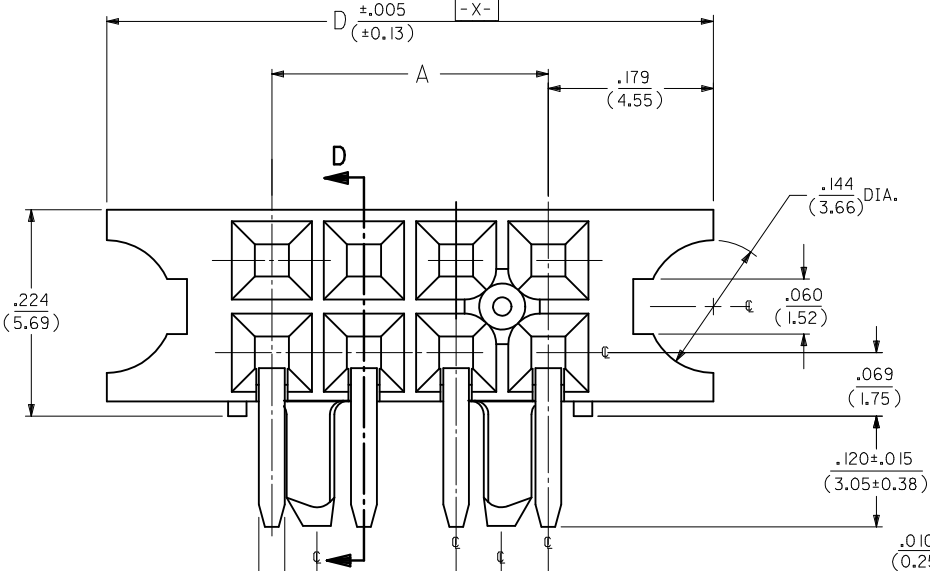

NOTE FOR LEAD FREE CONVERSION:

THE PRIMARY SHIPPING CARTON WILL BE LABELED "COMPLIANT TO RoHS DIRECTIVE 2002/95/EC AND ELV ANNEX II OF DIRECTIVE 2000/53/EC". CARTONS WITHOUT THIS LABEL MAY CONTAIN PRODUCT WITH LEAD.

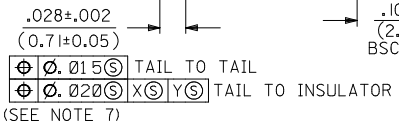

OPTION "I" ASSEMBLY

STANDARD HOUSING W/ PEGS AND MOUNTING EARS

ADD OPTION K & L	EC NO: S2010-0534	2009/12/30
	DRWN:SKANG	2010/01/08
K	CHKD:ATSEE	2010/01/14
	APPR:MLONG	2010/01/14
REV	DESCRIPTION	

QUALITY SYMBOLS	$F_A=0$
	$F_C=0$
GENERAL TOLERANCES (UNLESS SPECIFIED)	ANGULAR $\pm 1/2^\circ$
	DRAFT WHERE APPLICABLE MUST REMAIN WITHIN DIMENSIONS

DIMENSION STYLE		SCALE	DESIGN UNITS	THIRD ANGLE PROJECTION
IN/MM		NTS	INCH	
DRAWN BY	DATE	TITLE		
DJB	1991/10/21	EARLY ENTRY R/A RECPT		
CHECKED BY	DATE	.120"PC TAIL W/O LOWER ROW PINSTOP-.100" GRID		
DJB	1991/10/21	MOLEX INCORPORATED		
APPROVED BY	DATE	MATERIAL NO.		
MLONG	2010/01/14	DOCUMENT NO.		
SEE TABLE		SDA-71973-****		
SIZE	THIS DRAWING CONTAINS INFORMATION THAT IS PROPRIETARY TO MOLEX INCORPORATED AND SHOULD NOT BE USED WITHOUT WRITTEN PERMISSION			
A3				

DRAWN BY		DATE	TITLE	
DJB		1991/10/21	EARLY ENTRY R/A RECPT	
CHECKED BY		DATE	.120"PC TAIL W/O LOWER ROW PINSTOP-.100" GRID	
DJB		1991/10/21	MOLEX INCORPORATED	
APPROVED BY		DATE	MATERIAL NO.	
MLONG		2010/01/14	DOCUMENT NO.	
SEE TABLE		SDA-71973-****		SHEET NO.
				5 OF 26

9 8 7 6 5 4 3 2 1

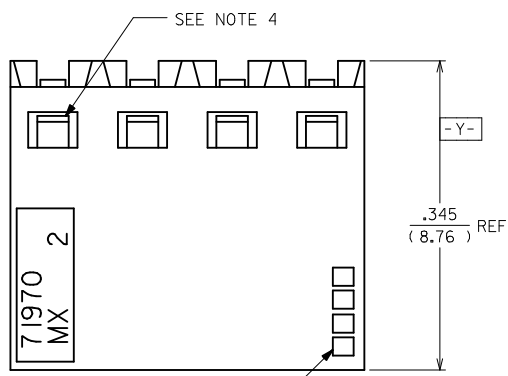

4 DIGIT DATE CODE  
SEE NOTE 5

**FINISHES**

- 15 GOLD .000015 MINIMUM GOLD PLATE IN SELECT AREA OVER .000050 MINIMUM NICKEL UNDERPLATE OVER-ALL WITH .000075 MINIMUM TIN PLATE IN SELECT AREA.
- 30 GOLD .000030 MINIMUM GOLD PLATE IN SELECT AREA OVER .000050 MINIMUM NICKEL UNDERPLATE OVER-ALL WITH .000075 MINIMUM TIN PLATE IN SELECT AREA.
- 50 GOLD .000050 MINIMUM GOLD PLATE IN SELECT AREA OVER .000050 MINIMUM NICKEL UNDERPLATE OVER-ALL WITH .000100 MINIMUM TIN PLATE IN SELECT AREA.

**NOTES:**

- 1.) MATERIAL -  
INSULATOR - LCP, UL 94V-0, COLOR BLACK  
CONTACTS - PHOSPHOR BRONZE
- 2.) SEE SHT. 25 FOR CHART DIMENSIONS AND ITEM NO.'S
- 3.) RECOMMENDED MATING PIN LENGTH:  
LOWER ROW - .200" MINIMUM, .285" MAX.  
UPPER ROW - .200" MINIMUM
- 4.) REFER TO PRODUCT SPECIFICATION PS-71973-9999 FOR PERFORMANCE DATA
- 5.) MANUFACTURED DATE CODE - YEAR, WEEK.
- 6.) PACKAGING: FOR THIS PRODUCT IN TUBES SEE SHT. 25

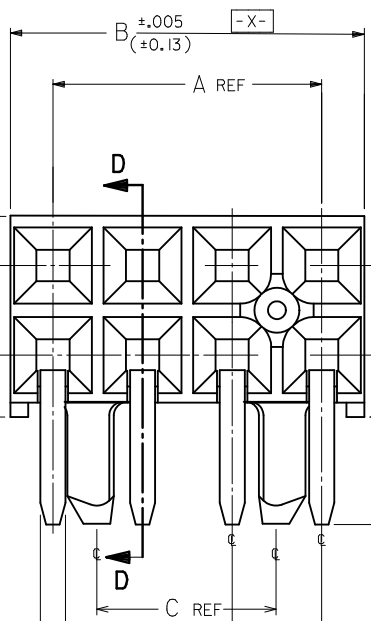

**SECTION D-D**

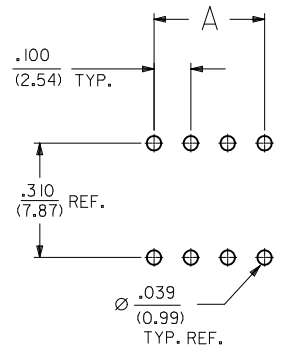
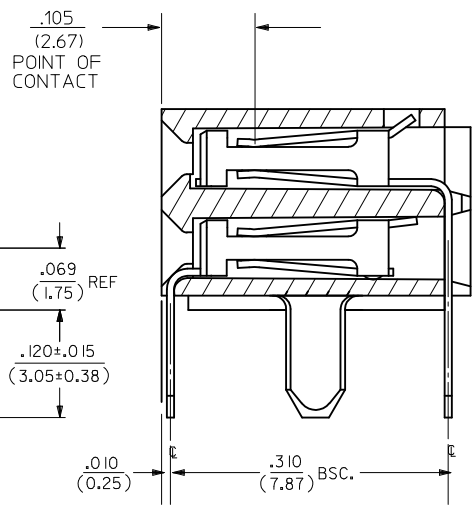

RECOMMENDED P.C.B.  
LAYOUT

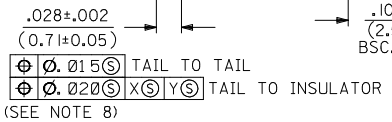

⊕ ⊕ .015 ⊕ TAIL TO TAIL  
⊕ ⊕ .020 ⊕ X ⊕ Y ⊕ TAIL TO INSULATOR  
(SEE NOTE 8)

OPTION "K" ASSEMBLY  
STANDARD HOUSING W/ PEGS

ADD OPTION K & L EC NO: S2010-0534 DRWN:SKANG 2009/12/30 CHYKD:ATSEE 2010/01/08 APPR:MLONG 2010/01/14	QUALITY SYMBOLS	GENERAL TOLERANCES (UNLESS SPECIFIED)		DIMENSION STYLE IN/MM		SCALE NTS	DESIGN UNITS INCH	THIRD ANGLE PROJECTION
	$F_A = 0$ $F_C = 0$ $F_P = 0$	4 PLACES ± --- ± --- 3 PLACES ± --- ± .010 2 PLACES ± 0.25 ± --- 1 PLACE ± --- ± ---	mm	INCH	DRAWN BY DJB	DATE 1991/10/21	TITLE	EARLY ENTRY R/A RECPT .120" PC TAIL W/O LOWER ROW PINSTOP-.100" GRID
		ANGULAR ± 1/2°		CHECKED BY DJB	DATE 1991/10/21		MOLEX INCORPORATED DOCUMENT NO. SDA-71973-****	
		DRAFT WHERE APPLICABLE MUST REMAIN WITHIN DIMENSIONS			APPROVED BY MLONG	DATE 2010/01/14		
		SEE TABLE		THIS DRAWING CONTAINS INFORMATION THAT IS PROPRIETARY TO MOLEX INCORPORATED AND SHOULD NOT BE USED WITHOUT WRITTEN PERMISSION				

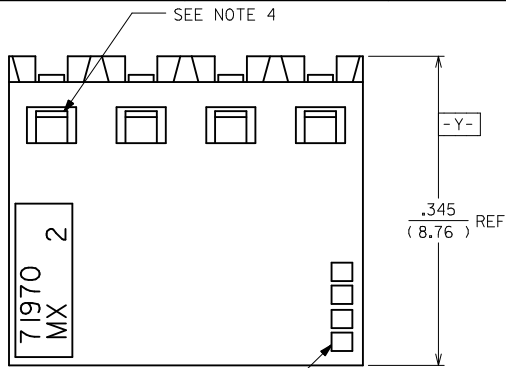

- FINISHES**
- 15 GOLD .000015 MINIMUM GOLD PLATE IN SELECT AREA OVER .000050 MINIMUM NICKEL UNDERPLATE OVER-ALL WITH .000075 MINIMUM TIN PLATE IN SELECT AREA.
  - 30 GOLD .000030 MINIMUM GOLD PLATE IN SELECT AREA OVER .000050 MINIMUM NICKEL UNDERPLATE OVER-ALL WITH .000075 MINIMUM TIN PLATE IN SELECT AREA.
  - 50 GOLD .000050 MINIMUM GOLD PLATE IN SELECT AREA OVER .000050 MINIMUM NICKEL UNDERPLATE OVER-ALL WITH .000100 MINIMUM TIN PLATE IN SELECT AREA.

- NOTES:**
- 1.) MATERIAL-  
INSULATOR - LCP, UL 94V-0, COLOR BLACK  
CONTACTS - PHOSPHOR BRONZE
  - 2.) SEE SHT. 22 FOR CHART DIMENSIONS AND ITEM NO.'S
  - 3.) RECOMMENDED MATING PIN LENGTH:  
LOWER ROW - .200" MINIMUM, .250" MAX.  
UPPER ROW - .200" MINIMUM
  - 4.) REFER TO PRODUCT SPECIFICATION PS-71973-9999 FOR PERFORMANCE DATA
  - 5.) MANUFACTURED DATE CODE - YEAR, WEEK.
  - 6.) PACKAGING: FOR THIS PRODUCT IN TUBES SEE SHT. 26

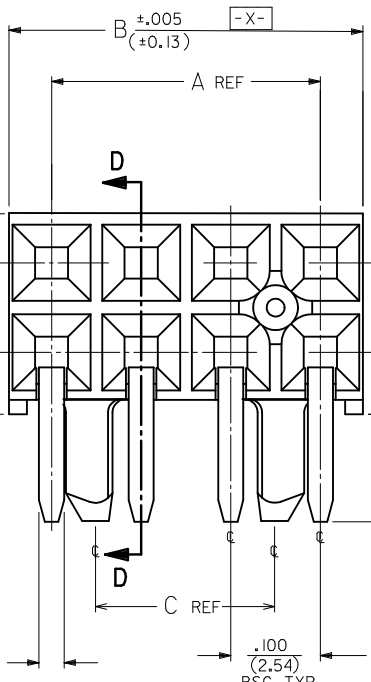

**SECTION D-D**

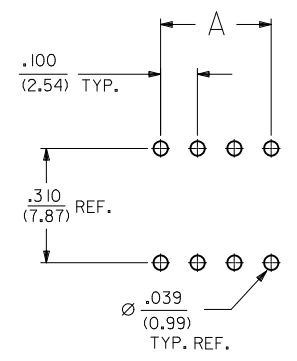
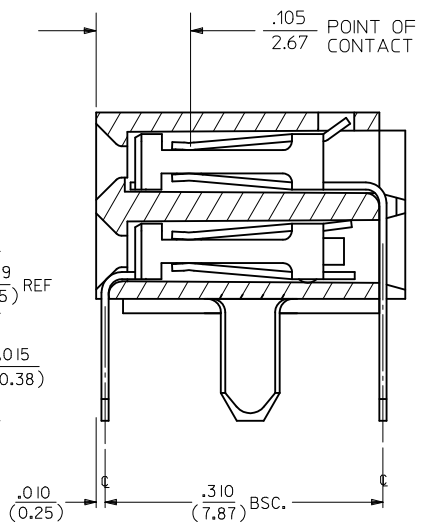

RECOMMENDED P.C.B. LAYOUT

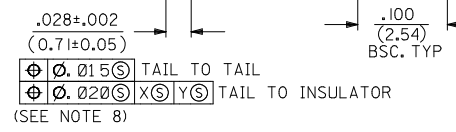

OPTION "L" ASSEMBLY  
STANDARD HOUSING W/ PEGS

<b>ADD OPTION K &amp; L</b> EC NO: S2010-0534 DRWN:SKANG 2009/12/30 CHYKD:ATSEE 2010/01/08 APPR:MLONG 2010/01/14	QUALITY SYMBOLS $\nabla_A = 0$ $\nabla_C = 0$ $\nabla_P = 0$	GENERAL TOLERANCES (UNLESS SPECIFIED) <table border="1"> <thead> <tr> <th></th> <th>mm</th> <th>INCH</th> </tr> </thead> <tbody> <tr> <td>4 PLACES</td> <td>± ---</td> <td>± ---</td> </tr> <tr> <td>3 PLACES</td> <td>± ---</td> <td>± .010</td> </tr> <tr> <td>2 PLACES</td> <td>± 0.25</td> <td>± ---</td> </tr> <tr> <td>1 PLACE</td> <td>± ---</td> <td>± ---</td> </tr> </tbody> </table> ANGULAR ± 1/2°		mm	INCH	4 PLACES	± ---	± ---	3 PLACES	± ---	± .010	2 PLACES	± 0.25	± ---	1 PLACE	± ---	± ---	DIMENSION STYLE IN/MM DRAWN BY: DJB DATE: 1991/10/21 CHECKED BY: DJB DATE: 1991/10/21 APPROVED BY: MLONG DATE: 2010/01/14	SCALE NTS DESIGN UNITS INCH THIRD ANGLE PROJECTION	TITLE EARLY ENTRY R/A RECPT .120" PC TAIL W/O LOWER ROW PINSTOP-.100" GRID MOLEX INCORPORATED DOCUMENT NO. SDA-71973-****	SHEET NO. 7 OF 26
		mm	INCH																		
	4 PLACES	± ---	± ---																		
	3 PLACES	± ---	± .010																		
2 PLACES	± 0.25	± ---																			
1 PLACE	± ---	± ---																			
DRAFT WHERE APPLICABLE MUST REMAIN WITHIN DIMENSIONS	SEE TABLE	MATERIAL NO.	THIS DRAWING CONTAINS INFORMATION THAT IS PROPRIETARY TO MOLEX INCORPORATED AND SHOULD NOT BE USED WITHOUT WRITTEN PERMISSION																		
SIZE A3																					
REV K																					

10		9		8		7		6		5		4		3		2		1									
NO. OF CKTS		OPTION A ASSEMBLY PACKAGED IN TUBES PER PK-70873-0138 (SEE SHEET I FOR FINISH SPECIFICATIONS)						DIMENSION				NO. OF CKTS		OPTION A ASSEMBLY PACKAGED IN TUBES PER PK-70873-0138 (SEE SHEET I FOR FINISH SPECIFICATIONS)						DIMENSION							
PER ROW	TOTAL	15 GOLD		30 GOLD		50 GOLD		A	B			PER ROW	TOTAL	15 GOLD		30 GOLD		50 GOLD		A	B						
4	8			71973-0204	71973-0304	71973-0404	.300 (7.62)	.395 (10.03)				33	66		71973-0233	71973-0333	71973-0433			3.200 (81.28)	3.295 (83.69)						
5	10			71973-0205	71973-0305	71973-0405	.400 (10.16)	.495 (12.57)				34	68		71973-0234	71973-0334	71973-0434			3.300 (83.82)	3.395 (86.23)						
6	12			71973-0206	71973-0306	71973-0406	.500 (12.70)	.595 (15.11)				35	70		71973-0235	71973-0335	71973-0435			3.400 (86.36)	3.495 (88.77)						
7	14			71973-0207	71973-0307	71973-0407	.600 (15.24)	.695 (17.65)				36	72		71973-0236	71973-0336	71973-0436			3.500 (88.90)	3.595 (91.31)						
8	16			71973-0208	71973-0308	71973-0408	.700 (17.78)	.795 (20.19)																			
9	18			71973-0209	71973-0309	71973-0409	.800 (20.32)	.895 (22.73)																			
10	20			71973-0210	71973-0310	71973-0410	.900 (22.86)	.995 (25.27)																			
11	22			71973-0211	71973-0311	71973-0411	1.000 (25.40)	1.095 (27.81)																			
12	24			71973-0212	71973-0312	71973-0412	1.100 (27.94)	1.195 (30.35)																			
13	26			71973-0213	71973-0313	71973-0413	1.200 (30.48)	1.295 (32.89)																			
14	28			71973-0214	71973-0314	71973-0414	1.300 (33.02)	1.395 (35.43)																			
15	30			71973-0215	71973-0315	71973-0415	1.400 (35.56)	1.495 (37.97)																			
16	32			71973-0216	71973-0316	71973-0416	1.500 (38.10)	1.595 (40.51)																			
17	34			71973-0217	71973-0317	71973-0417	1.600 (40.64)	1.695 (43.05)																			
18	36			71973-0218	71973-0318	71973-0418	1.700 (43.18)	1.795 (45.59)																			
19	38			71973-0219	71973-0319	71973-0419	1.800 (45.72)	1.895 (48.13)																			
20	40			71973-0220	71973-0320	71973-0420	1.900 (48.26)	1.995 (50.67)																			
21	42			71973-0221	71973-0321	71973-0421	2.000 (50.80)	2.095 (53.21)																			
22	44			71973-0222	71973-0322	71973-0422	2.100 (53.34)	2.195 (55.75)																			
23	46			71973-0223	71973-0323	71973-0423	2.200 (55.88)	2.295 (58.29)																			
24	48			71973-0224	71973-0324	71973-0424	2.300 (58.42)	2.395 (60.83)																			
25	50			71973-0225	71973-0325	71973-0425	2.400 (60.96)	2.495 (63.37)																			
26	52			71973-0226	71973-0326	71973-0426	2.500 (63.50)	2.595 (65.91)																			
27	54			71973-0227	71973-0327	71973-0427	2.600 (66.04)	2.695 (68.45)																			
28	56			71973-0228	71973-0328	71973-0428	2.700 (68.58)	2.795 (70.99)																			
29	58			71973-0229	71973-0329	71973-0429	2.800 (71.12)	2.895 (73.53)																			
30	60			71973-0230	71973-0330	71973-0430	2.900 (73.66)	2.995 (76.07)																			
31	62			71973-0231	71973-0331	71973-0431	3.000 (76.20)	3.095 (78.61)																			
32	64			71973-0232	71973-0332	71973-0432	3.100 (78.74)	3.195 (81.15)																			

<b>ADD OPTION K &amp; L</b> EC NO: S2010-0534 DRWN:SKANG 2009/12/30 CHKD:ATSEE 2010/01/08 APPR:MLONG 2010/01/14	QUALITY SYMBOLS $F_A=0$ $F_C=0$ $F_P=0$	GENERAL TOLERANCES (UNLESS SPECIFIED)		DIMENSION STYLE IN/MM		SCALE NTS	DESIGN UNITS INCH	THIRD ANGLE PROJECTION																	
		<table border="1"> <tr> <th></th> <th>mm</th> <th>INCH</th> </tr> <tr> <td>4 PLACES</td> <td>± ---</td> <td>± ---</td> </tr> <tr> <td>3 PLACES</td> <td>± ---</td> <td>± .010</td> </tr> <tr> <td>2 PLACES</td> <td>± 0.25</td> <td>± ---</td> </tr> <tr> <td>1 PLACE</td> <td>± ---</td> <td>± ---</td> </tr> </table>			mm	INCH	4 PLACES	± ---	± ---	3 PLACES	± ---	± .010	2 PLACES	± 0.25	± ---	1 PLACE	± ---	± ---	DRAWN BY DJB		DATE 1991/10/21	TITLE EARLY ENTRY R/A RECPT .120"PC TAIL W/O LOWER ROW PINSTOP-.100" GRID			
			mm	INCH																					
		4 PLACES	± ---	± ---																					
3 PLACES	± ---	± .010																							
2 PLACES	± 0.25	± ---																							
1 PLACE	± ---	± ---																							
APPROVED BY MLONG		DATE 2010/01/14		MOLEX INCORPORATED																					
DRAFT WHERE APPLICABLE MUST REMAIN WITHIN DIMENSIONS		SEE TABLE		MATERIAL NO.		DOCUMENT NO.		SHEET NO.																	



10		9		8		7		6		5		4		3		2		1					
NO. OF CKTS		OPTION B ASSEMBLY PACKAGED IN TUBES PER PK-70873-0139 (SEE SHEET I FOR PLATING SPECIFICATIONS)						DIMENSION				NO. OF CKTS		OPTION B ASSEMBLY PACKAGED IN TUBES PER PK-70873-0139 (SEE SHEET I FOR PLATING SPECIFICATIONS)						DIMENSION			
PER ROW	TOTAL	OPT. J ASSY 15 GOLD		15 GOLD	30 GOLD	50 GOLD	A	B		D	PER ROW	TOTAL	OPT. J ASSY 15 GOLD		15 GOLD	30 GOLD	50 GOLD	A	B		D		
4	8			71973-1004	71973-1104	71973-1204	.300 (7.62)	.395 (10.03)		.658 (16.71)	33	66			71973-1033	71973-1133	71973-1233	3.200 (81.28)	3.295 (83.69)		3.558 (90.37)		
5	10			71973-1005	71973-1105	71973-1205	.400 (10.16)	.495 (12.57)		.758 (19.25)	34	68			71973-1034	71973-1134	71973-1234	3.300 (83.82)	3.395 (86.23)		3.658 (92.91)		
6	12			71973-1006	71973-1106	71973-1206	.500 (12.70)	.595 (15.11)		.858 (21.79)	35	70			71973-1035	71973-1135	71973-1235	3.400 (86.36)	3.495 (88.77)		3.758 (95.45)		
7	14			71973-1007	71973-1107	71973-1207	.600 (15.24)	.695 (17.65)		.958 (24.33)	36	72			71973-1036	71973-1136	71973-1236	3.500 (88.90)	3.595 (91.31)		3.858 (97.99)		
8	16			71973-1008	71973-1108	71973-1208	.700 (17.78)	.795 (20.19)		1.058 (26.87)													
9	18			71973-1009	71973-1109	71973-1209	.800 (20.32)	.895 (22.73)		1.158 (29.41)													
10	20			71973-1010	71973-1110	71973-1210	.900 (22.86)	.995 (25.27)		1.258 (31.95)													
11	22			71973-1011	71973-1111	71973-1211	1.000 (25.40)	1.095 (27.81)		1.358 (34.49)													
12	24			71973-1012	71973-1112	71973-1212	1.100 (27.94)	1.195 (30.35)		1.458 (37.03)													
13	26			71973-1013	71973-1113	71973-1213	1.200 (30.48)	1.295 (32.89)		1.558 (39.57)													
14	28			71973-1014	71973-1114	71973-1214	1.300 (33.02)	1.395 (35.43)		1.658 (42.11)													
15	30		71973-1315	71973-1015	71973-1115	71973-1215	1.400 (35.56)	1.495 (37.97)		1.758 (44.65)													
16	32			71973-1016	71973-1116	71973-1216	1.500 (38.10)	1.595 (40.51)		1.858 (47.19)													
17	34			71973-1017	71973-1117	71973-1217	1.600 (40.64)	1.695 (43.05)		1.958 (49.73)													
18	36			71973-1018	71973-1118	71973-1218	1.700 (43.18)	1.795 (45.59)		2.058 (52.27)													
19	38			71973-1019	71973-1119	71973-1219	1.800 (45.72)	1.895 (48.13)		2.158 (54.81)													
20	40		71973-1320	71973-1020	71973-1120	71973-1220	1.900 (48.26)	1.995 (50.67)		2.258 (57.35)													
21	42			71973-1021	71973-1121	71973-1221	2.000 (50.80)	2.095 (53.21)		2.358 (59.89)													
22	44			71973-1022	71973-1122	71973-1222	2.100 (53.34)	2.195 (55.75)		2.458 (62.43)													
23	46			71973-1023	71973-1123	71973-1223	2.200 (55.88)	2.295 (58.29)		2.558 (64.97)													
24	48			71973-1024	71973-1124	71973-1224	2.300 (58.42)	2.395 (60.83)		2.658 (67.51)													
25	50			71973-1025	71973-1125	71973-1225	2.400 (60.96)	2.495 (63.37)		2.758 (70.05)													
26	52			71973-1026	71973-1126	71973-1226	2.500 (63.50)	2.595 (65.91)		2.858 (72.59)													
27	54			71973-1027	71973-1127	71973-1227	2.600 (66.04)	2.695 (68.45)		2.958 (75.13)													
28	56			71973-1028	71973-1128	71973-1228	2.700 (68.58)	2.795 (70.99)		3.058 (77.67)													
29	58			71973-1029	71973-1129	71973-1229	2.800 (71.12)	2.895 (73.53)		3.158 (80.21)													
30	60			71973-1030	71973-1130	71973-1230	2.900 (73.66)	2.995 (76.07)		3.258 (82.75)													
31	62			71973-1031	71973-1131	71973-1231	3.000 (76.20)	3.095 (78.61)		3.358 (85.29)													
32	64			71973-1032	71973-1132	71973-1232	3.100 (78.74)	3.195 (81.15)		3.458 (87.83)													

<p>OPTION "J" IS THE SAME AS "B" EXCEPT DATE CODE IS NOT STAMPED ON HOUSING.</p>	<p>ADD OPTION K &amp; L EC NO: S2010-0534 DRWN:SKANG 2009/12/30 CHKD:ATSEE 2010/01/08 APPR:MLONG 2010/01/14</p>	<p>QUALITY SYMBOLS ▽<sub>A</sub>=0 ▽<sub>C</sub>=0 ▽<sub>P</sub>=0</p>	GENERAL TOLERANCES (UNLESS SPECIFIED)		DIMENSION STYLE IN/MM		SCALE NTS	DESIGN UNITS INCH	THIRD ANGLE PROJECTION																		
			<table border="1"> <tr> <th></th> <th>mm</th> <th>INCH</th> </tr> <tr> <td>4 PLACES</td> <td>± ---</td> <td>± ---</td> </tr> <tr> <td>3 PLACES</td> <td>± ---</td> <td>± .010</td> </tr> <tr> <td>2 PLACES</td> <td>± 0.25</td> <td>± ---</td> </tr> <tr> <td>1 PLACE</td> <td>± ---</td> <td>± ---</td> </tr> </table>			mm	INCH	4 PLACES	± ---	± ---	3 PLACES	± ---	± .010	2 PLACES	± 0.25	± ---	1 PLACE	± ---	± ---	DRAWN BY DJB		DATE 1991/10/21		<p>TITLE EARLY ENTRY R/A RECPT .120"PC TAIL W/O LOWER ROW PINSTOP-.100" GRID</p>			
				mm	INCH																						
			4 PLACES	± ---	± ---																						
3 PLACES	± ---	± .010																									
2 PLACES	± 0.25	± ---																									
1 PLACE	± ---	± ---																									
CHECKED BY DJB		DATE 1991/10/21																									
APPROVED BY MLONG		DATE 2010/01/14		<p>MOLEX MOLEX INCORPORATED</p>																							
DRAFT WHERE APPLICABLE MUST REMAIN WITHIN DIMENSIONS		SEE TABLE		MATERIAL NO.		DOCUMENT NO.		SHEET NO.																			

10		9		8		7		6		5		4		3		2		1											
NO. OF CKTS		OPTION A ASSEMBLY PACKAGED IN TRAYS PER PK-70873-0239 (SEE SHEET 1 FOR FINISH SPECIFICATIONS)						DIMENSION				NO. OF CKTS		OPTION A ASSEMBLY PACKAGED IN TRAYS PER PK-70873-0239 (SEE SHEET 1 FOR FINISH SPECIFICATIONS)						DIMENSION									
PER ROW	TOTAL	15 GOLD		30 GOLD		50 GOLD		A	B					15 GOLD		30 GOLD		50 GOLD		A	B								
4	8			71973-6604	71973-6704	71973-6804	.300 (7.62)	.395 (10.03)							71973-6633	71973-6733	71973-6833	3.200 (81.28)	3.295 (83.69)										
5	10			71973-6605	71973-6705	71973-6805	.400 (10.16)	.495 (12.57)							71973-6634	71973-6734	71973-6834	3.300 (83.82)	3.395 (86.23)										
6	12			71973-6606	71973-6706	71973-6806	.500 (12.70)	.595 (15.11)							71973-6635	71973-6735	71973-6835	3.400 (86.36)	3.495 (88.77)										
7	14			71973-6607	71973-6707	71973-6807	.600 (15.24)	.695 (17.65)							71973-6636	71973-6736	71973-6836	3.500 (88.90)	3.595 (91.31)										
8	16			71973-6608	71973-6708	71973-6808	.700 (17.78)	.795 (20.19)																					
9	18			71973-6609	71973-6709	71973-6809	.800 (20.32)	.895 (22.73)																					
10	20			71973-6610	71973-6710	71973-6810	.900 (22.86)	.995 (25.27)																					
11	22			71973-6611	71973-6711	71973-6811	1.000 (25.40)	1.095 (27.81)																					
12	24			71973-6612	71973-6712	71973-6812	1.100 (27.94)	1.195 (30.35)																					
13	26			71973-6613	71973-6713	71973-6813	1.200 (30.48)	1.295 (32.89)																					
14	28			71973-6614	71973-6714	71973-6814	1.300 (33.02)	1.395 (35.43)																					
15	30			71973-6615	71973-6715	71973-6815	1.400 (35.56)	1.495 (37.97)																					
16	32			71973-6616	71973-6716	71973-6816	1.500 (38.10)	1.595 (40.51)																					
17	34			71973-6617	71973-6717	71973-6817	1.600 (40.64)	1.695 (43.05)																					
18	36			71973-6618	71973-6718	71973-6818	1.700 (43.18)	1.795 (45.59)																					
19	38			71973-6619	71973-6719	71973-6819	1.800 (45.72)	1.895 (48.13)																					
20	40			71973-6620	71973-6720	71973-6820	1.900 (48.26)	1.995 (50.67)																					
21	42			71973-6621	71973-6721	71973-6821	2.000 (50.80)	2.095 (53.21)																					
22	44			71973-6622	71973-6722	71973-6822	2.100 (53.34)	2.195 (55.75)																					
23	46			71973-6623	71973-6723	71973-6823	2.200 (55.88)	2.295 (58.29)																					
24	48			71973-6624	71973-6724	71973-6824	2.300 (58.42)	2.395 (60.83)																					
25	50			71973-6625	71973-6725	71973-6825	2.400 (60.96)	2.495 (63.37)																					
26	52			71973-6626	71973-6726	71973-6826	2.500 (63.50)	2.595 (65.91)																					
27	54			71973-6627	71973-6727	71973-6827	2.600 (66.04)	2.695 (68.45)																					
28	56			71973-6628	71973-6728	71973-6828	2.700 (68.58)	2.795 (70.99)																					
29	58			71973-6629	71973-6729	71973-6829	2.800 (71.12)	2.895 (73.53)																					
30	60			71973-6630	71973-6730	71973-6830	2.900 (73.66)	2.995 (76.07)																					
31	62			71973-6631	71973-6731	71973-6831	3.000 (76.20)	3.095 (78.61)																					
32	64			71973-6632	71973-6732	71973-6832	3.100 (78.74)	3.195 (81.15)																					

<b>ADD OPTION K &amp; L</b> EC NO: S2010-0534 DRWN:SKANG 2009/12/30 CHKD:ATSEE 2010/01/08 APPR:MLONG 2010/01/14	DESCRIPTION REV	QUALITY SYMBOLS	GENERAL TOLERANCES (UNLESS SPECIFIED)	DIMENSION STYLE	SCALE	DESIGN UNITS	THIRD ANGLE PROJECTION															
		$\nabla_A = 0$ $\nabla_C = 0$ $\nabla_P = 0$	<table border="1"> <tr> <th></th> <th>mm</th> <th>INCH</th> </tr> <tr> <td>4 PLACES</td> <td>± ---</td> <td>± ---</td> </tr> <tr> <td>3 PLACES</td> <td>± ---</td> <td>± .010</td> </tr> <tr> <td>2 PLACES</td> <td>± 0.25</td> <td>± ---</td> </tr> <tr> <td>1 PLACE</td> <td>± ---</td> <td>± ---</td> </tr> </table>		mm	INCH	4 PLACES	± ---	± ---	3 PLACES	± ---	± .010	2 PLACES	± 0.25	± ---	1 PLACE	± ---	± ---	IN/MM	NTS	INCH	
			mm	INCH																		
		4 PLACES	± ---	± ---																		
3 PLACES	± ---	± .010																				
2 PLACES	± 0.25	± ---																				
1 PLACE	± ---	± ---																				
	<table border="1"> <tr> <td>DRAWN BY</td> <td>DATE</td> <td>TITLE</td> </tr> <tr> <td>DJB</td> <td>1991/10/21</td> <td>EARLY ENTRY R/A RECPT .120"PC TAIL W/O LOWER ROW PINSTOP-.100" GRID</td> </tr> <tr> <td>CHECKED BY</td> <td>DATE</td> <td></td> </tr> <tr> <td>DJB</td> <td>1991/10/21</td> <td></td> </tr> <tr> <td>APPROVED BY</td> <td>DATE</td> <td></td> </tr> <tr> <td>MLONG</td> <td>2010/01/14</td> <td></td> </tr> </table>	DRAWN BY	DATE	TITLE	DJB	1991/10/21	EARLY ENTRY R/A RECPT .120"PC TAIL W/O LOWER ROW PINSTOP-.100" GRID	CHECKED BY	DATE		DJB	1991/10/21		APPROVED BY	DATE		MLONG	2010/01/14				MOLEX INCORPORATED
DRAWN BY	DATE	TITLE																				
DJB	1991/10/21	EARLY ENTRY R/A RECPT .120"PC TAIL W/O LOWER ROW PINSTOP-.100" GRID																				
CHECKED BY	DATE																					
DJB	1991/10/21																					
APPROVED BY	DATE																					
MLONG	2010/01/14																					
	DRAFT WHERE APPLICABLE MUST REMAIN WITHIN DIMENSIONS	SEE TABLE	MATERIAL NO. SDA-71973-****	DOCUMENT NO.	SHEET NO. 10 OF 26																	

NO. OF CKTS		OPTION B ASSEMBLY PACKAGED IN TRAYS PER PK-70873-0239 (SEE SHEET 1 FOR FINISH SPECIFICATIONS)					DIMENSION			NO. OF CKTS		OPTION B ASSEMBLY PACKAGED IN TRAYS PER PK-70873-0239 (SEE SHEET 1 FOR FINISH SPECIFICATIONS)					DIMENSION						
PER ROW	TOTAL	15 GOLD			30 GOLD		50 GOLD		A	B	D	PER ROW	TOTAL	15 GOLD			30 GOLD		50 GOLD		A	B	D
4	8			71973-7004	71973-7104	71973-7204	.300 (7.62)	.395 (10.03)	.658 (16.71)			33	66			71973-7033	71973-7133	71973-7233	3.200 (81.28)	3.295 (83.69)	3.558 (90.37)		
5	10			71973-7005	71973-7105	71973-7205	.400 (10.16)	.495 (12.57)	.758 (19.25)			34	68			71973-7034	71973-7134	71973-7234	3.300 (83.82)	3.395 (86.23)	3.658 (92.91)		
6	12			71973-7006	71973-7106	71973-7206	.500 (12.70)	.595 (15.11)	.858 (21.79)			35	70			71973-7035	71973-7135	71973-7235	3.400 (86.36)	3.495 (88.77)	3.758 (95.45)		
7	14			71973-7007	71973-7107	71973-7207	.600 (15.24)	.695 (17.65)	.958 (24.33)			36	72			71973-7036	71973-7136	71973-7236	3.500 (88.90)	3.595 (91.31)	3.858 (97.99)		
8	16			71973-7008	71973-7108	71973-7208	.700 (17.78)	.795 (20.19)	1.058 (26.87)														
9	18			71973-7009	71973-7109	71973-7209	.800 (20.32)	.895 (22.73)	1.158 (29.41)														
10	20			71973-7010	71973-7110	71973-7210	.900 (22.86)	.995 (25.27)	1.258 (31.95)														
11	22			71973-7011	71973-7111	71973-7211	1.000 (25.40)	1.095 (27.81)	1.358 (34.49)														
12	24			71973-7012	71973-7112	71973-7212	1.100 (27.94)	1.195 (30.35)	1.458 (37.03)														
13	26			71973-7013	71973-7113	71973-7213	1.200 (30.48)	1.295 (32.89)	1.558 (39.57)														
14	28			71973-7014	71973-7114	71973-7214	1.300 (33.02)	1.395 (35.43)	1.658 (42.11)														
15	30			71973-7015	71973-7115	71973-7215	1.400 (35.56)	1.495 (37.97)	1.758 (44.65)														
16	32			71973-7016	71973-7116	71973-7216	1.500 (38.10)	1.595 (40.51)	1.858 (47.19)														
17	34			71973-7017	71973-7117	71973-7217	1.600 (40.64)	1.695 (43.05)	1.958 (49.73)														
18	36			71973-7018	71973-7118	71973-7218	1.700 (43.18)	1.795 (45.59)	2.058 (52.27)														
19	38			71973-7019	71973-7119	71973-7219	1.800 (45.72)	1.895 (48.13)	2.158 (54.81)														
20	40			71973-7020	71973-7120	71973-7220	1.900 (48.26)	1.995 (50.67)	2.258 (57.35)														
21	42			71973-7021	71973-7121	71973-7221	2.000 (50.80)	2.095 (53.21)	2.358 (59.89)														
22	44			71973-7022	71973-7122	71973-7222	2.100 (53.34)	2.195 (55.75)	2.458 (62.43)														
23	46			71973-7023	71973-7123	71973-7223	2.200 (55.88)	2.295 (58.29)	2.558 (64.97)														
24	48			71973-7024	71973-7124	71973-7224	2.300 (58.42)	2.395 (60.83)	2.658 (67.51)														
25	50			71973-7025	71973-7125	71973-7225	2.400 (60.96)	2.495 (63.37)	2.758 (70.05)														
26	52			71973-7026	71973-7126	71973-7226	2.500 (63.50)	2.595 (65.91)	2.858 (72.59)														
27	54			71973-7027	71973-7127	71973-7227	2.600 (66.04)	2.695 (68.45)	2.958 (75.13)														
28	56			71973-7028	71973-7128	71973-7228	2.700 (68.58)	2.795 (70.99)	3.058 (77.67)														
29	58			71973-7029	71973-7129	71973-7229	2.800 (71.12)	2.895 (73.53)	3.158 (80.21)														
30	60			71973-7030	71973-7130	71973-7230	2.900 (73.66)	2.995 (76.07)	3.258 (82.75)														
31	62			71973-7031	71973-7131	71973-7231	3.000 (76.20)	3.095 (78.61)	3.358 (85.29)														
32	64			71973-7032	71973-7132	71973-7232	3.100 (78.74)	3.195 (81.15)	3.458 (87.83)														

<b>ADD OPTION K &amp; L</b> EC NO: S2010-0534 DRWN:SKANG 2009/12/30 CHKD:ATSEE 2010/01/08 APPR:MLONG 2010/01/14	QUALITY SYMBOLS	GENERAL TOLERANCES (UNLESS SPECIFIED)	DIMENSION STYLE	SCALE	DESIGN UNITS	THIRD ANGLE PROJECTION	
	$F_A=0$ $F_G=0$ $F_P=0$	mm    INCH 4 PLACES ± --- ± --- 3 PLACES ± --- ± .010 2 PLACES ± 0.25 ± --- 1 PLACE ± --- ± --- ANGULAR ± 1/2°	IN/MM DRAWN BY: DJB    DATE: 1991/10/21 CHECKED BY:    DATE: APPROVED BY:    DATE: 2010/01/14 MATERIAL NO.    DOCUMENT NO.	NTS TITLE: EARLY ENTRY R/A RECPT .120"PC TAIL W/O LOWER ROW PINSTOP-.100" GRID MOLEX INCORPORATED			
		DRAFT WHERE APPLICABLE MUST REMAIN WITHIN DIMENSIONS	SEE TABLE	SDA-71973-****			SHEET NO. 11 OF 26
			SIZE A3	THIS DRAWING CONTAINS INFORMATION THAT IS PROPRIETARY TO MOLEX INCORPORATED AND SHOULD NOT BE USED WITHOUT WRITTEN PERMISSION			

NO. OF CKTS		OPTION C ASSEMBLY PACKAGED IN TUBES PER PK-70873-0138 (SEE SHEET 1 FOR FINISH SPECIFICATIONS)					DIMENSION				NO. OF CKTS		OPTION C ASSEMBLY PACKAGED IN TUBES PER PK-70873-0138 (SEE SHEET 1 FOR FINISH SPECIFICATIONS)					DIMENSION					
PER ROW	TOTAL		15 GOLD	30 GOLD	50 GOLD	A	B				PER ROW	TOTAL		15 GOLD	30 GOLD	50 GOLD	A	B					
4	8	X	71973-1804	X	71973-1904	X	71973-2004	.300 (7.62)	.395 (10.03)		33	66	X	71973-1833	X	71973-1933	X	71973-2033	3.200 (81.28)	3.295 (83.69)			
5	10	X	71973-1805	X	71973-1905	X	71973-2005	.400 (10.16)	.495 (12.57)		34	68	X	71973-1834	X	71973-1934	X	71973-2034	3.300 (83.82)	3.395 (86.23)			
6	12	X	71973-1806	X	71973-1906	X	71973-2006	.500 (12.70)	.595 (15.11)		35	70	X	71973-1835	X	71973-1935	X	71973-2035	3.400 (86.36)	3.495 (88.77)			
7	14	X	71973-1807	X	71973-1907	X	71973-2007	.600 (15.24)	.695 (17.65)		36	72	X	71973-1836	X	71973-1936	X	71973-2036	3.500 (88.90)	3.595 (91.31)			
8	16	X	71973-1808	X	71973-1908	X	71973-2008	.700 (17.78)	.795 (20.19)														
9	18	X	71973-1809	X	71973-1909	X	71973-2009	.800 (20.32)	.895 (22.73)														
10	20	X	71973-1810	X	71973-1910	X	71973-2010	.900 (22.86)	.995 (25.27)														
11	22	X	71973-1811	X	71973-1911	X	71973-2011	1.000 (25.40)	1.095 (27.81)														
12	24	X	71973-1812	X	71973-1912	X	71973-2012	1.100 (27.94)	1.195 (30.35)														
13	26	X	71973-1813	X	71973-1913	X	71973-2013	1.200 (30.48)	1.295 (32.89)														
14	28	X	71973-1814	X	71973-1914	X	71973-2014	1.300 (33.02)	1.395 (35.43)														
15	30	X	71973-1815	X	71973-1915	X	71973-2015	1.400 (35.56)	1.495 (37.97)														
16	32	X	71973-1816	X	71973-1916	X	71973-2016	1.500 (38.10)	1.595 (40.51)														
17	34	X	71973-1817	X	71973-1917	X	71973-2017	1.600 (40.64)	1.695 (43.05)														
18	36	X	71973-1818	X	71973-1918	X	71973-2018	1.700 (43.18)	1.795 (45.59)														
19	38	X	71973-1819	X	71973-1919	X	71973-2019	1.800 (45.72)	1.895 (48.13)														
20	40	X	71973-1820	X	71973-1920	X	71973-2020	1.900 (48.26)	1.995 (50.67)														
21	42	X	71973-1821	X	71973-1921	X	71973-2021	2.000 (50.80)	2.095 (53.21)														
22	44	X	71973-1822	X	71973-1922	X	71973-2022	2.100 (53.34)	2.195 (55.75)														
23	46	X	71973-1823	X	71973-1923	X	71973-2023	2.200 (55.88)	2.295 (58.29)														
24	48	X	71973-1824	X	71973-1924	X	71973-2024	2.300 (58.42)	2.395 (60.83)														
25	50	X	71973-1825	X	71973-1925	X	71973-2025	2.400 (60.96)	2.495 (63.37)														
26	52	X	71973-1826	X	71973-1926	X	71973-2026	2.500 (63.50)	2.595 (65.91)														
27	54	X	71973-1827	X	71973-1927	X	71973-2027	2.600 (66.04)	2.695 (68.45)														
28	56	X	71973-1828	X	71973-1928	X	71973-2028	2.700 (68.58)	2.795 (70.99)														
29	58	X	71973-1829	X	71973-1929	X	71973-2029	2.800 (71.12)	2.895 (73.53)														
30	60	X	71973-1830	X	71973-1930	X	71973-2030	2.900 (73.66)	2.995 (76.07)														
31	62	X	71973-1831	X	71973-1931	X	71973-2031	3.000 (76.20)	3.095 (78.61)														
32	64	X	71973-1832	X	71973-1932	X	71973-2032	3.100 (78.74)	3.195 (81.15)														

*X* INDICATES TOOLING IS NOT AVAILABLE	<b>ADD OPTION K &amp; L</b> EC NO: S2010-0534 DRWN:SKANG 2009/12/30 CHKD:ATSEE 2010/01/08 APPR:MLONG 2010/01/14	QUALITY SYMBOLS $F_A=0$ $F_G=0$ $F_P=0$	GENERAL TOLERANCES (UNLESS SPECIFIED)		DIMENSION STYLE IN/MM		SCALE NTS	DESIGN UNITS INCH	THIRD ANGLE PROJECTION			
			4 PLACES	± ---	± ---	DRAWN BY DJB	DATE 1991/10/21	TITLE EARLY ENTRY R/A RECPT .120"PC TAIL W/O LOWER ROW PINSTOP-.100" GRID				
			3 PLACES	± ---	± .010	CHECKED BY DJB	DATE 1991/10/21	MOLEX INCORPORATED				
			2 PLACES	± 0.25	± ---	APPROVED BY MLONG	DATE 2010/01/14	DOCUMENT NO. SDA-71973-****				
1 PLACE	± ---	± ---	ANGULAR ± 1/2°		MATERIAL NO.		SHEET NO.		THIS DRAWING CONTAINS INFORMATION THAT IS PROPRIETARY TO MOLEX INCORPORATED AND SHOULD NOT BE USED WITHOUT WRITTEN PERMISSION			
DRAFT WHERE APPLICABLE MUST REMAIN WITHIN DIMENSIONS			SEE TABLE		SIZE A3		12 OF 26					

10		9			8			7			6			5			4			3			2			1							
NO. OF CKTS		OPTION D ASSEMBLY PACKAGED IN TUBES PER PK-70873-0139 (SEE SHEET 1 FOR FINISH SPECIFICATIONS)									DIMENSION						NO. OF CKTS		OPTION D ASSEMBLY PACKAGED IN TUBES PER PK-70873-0139 (SEE SHEET 1 FOR FINISH SPECIFICATIONS)									DIMENSION					
PER ROW	TOTAL	15 GOLD			30 GOLD			50 GOLD			A	B				D	PER ROW	TOTAL	15 GOLD			30 GOLD			50 GOLD			A	B				D
4	8	X	71973-2604	X	71973-2704	X	71973-2804	.300 (7.62)	.395 (10.03)	.658 (16.71)					33	66	X	71973-2633	X	71973-2733	X	71973-2833	3.200 (81.28)	3.295 (83.69)			3.558 (90.37)						
5	10	X	71973-2605	X	71973-2705	X	71973-2805	.400 (10.16)	.495 (12.57)	.758 (19.25)					34	68	X	71973-2634	X	71973-2734	X	71973-2834	3.300 (83.82)	3.395 (86.23)			3.658 (92.91)						
6	12	X	71973-2606	X	71973-2706	X	71973-2806	.500 (12.70)	.595 (15.11)	.858 (21.79)					35	70	X	71973-2635	X	71973-2735	X	71973-2835	3.400 (86.36)	3.495 (88.77)			3.758 (95.45)						
7	14	X	71973-2607	X	71973-2707	X	71973-2807	.600 (15.24)	.695 (17.65)	.958 (24.33)					36	72	X	71973-2636	X	71973-2736	X	71973-2836	3.500 (88.90)	3.595 (91.31)			3.858 (97.99)						
8	16	X	71973-2608	X	71973-2708	X	71973-2808	.700 (17.78)	.795 (20.19)	1.058 (26.87)																							
9	18	X	71973-2609	X	71973-2709	X	71973-2809	.800 (20.32)	.895 (22.73)	1.158 (29.41)																							
10	20	X	71973-2610	X	71973-2710	X	71973-2810	.900 (22.86)	.995 (25.27)	1.258 (31.95)																							
11	22	X	71973-2611	X	71973-2711	X	71973-2811	1.000 (25.40)	1.095 (27.81)	1.358 (34.49)																							
12	24	X	71973-2612	X	71973-2712	X	71973-2812	1.100 (27.94)	1.195 (30.35)	1.458 (37.03)																							
13	26	X	71973-2613	X	71973-2713	X	71973-2813	1.200 (30.48)	1.295 (32.89)	1.558 (39.57)																							
14	28	X	71973-2614	X	71973-2714	X	71973-2814	1.300 (33.02)	1.395 (35.43)	1.658 (42.11)																							
15	30	X	71973-2615	X	71973-2715	X	71973-2815	1.400 (35.56)	1.495 (37.97)	1.758 (44.65)																							
16	32	X	71973-2616	X	71973-2716	X	71973-2816	1.500 (38.10)	1.595 (40.51)	1.858 (47.19)																							
17	34	X	71973-2617	X	71973-2717	X	71973-2817	1.600 (40.64)	1.695 (43.05)	1.958 (49.73)																							
18	36	X	71973-2618	X	71973-2718	X	71973-2818	1.700 (43.18)	1.795 (45.59)	2.058 (52.27)																							
19	38	X	71973-2619	X	71973-2719	X	71973-2819	1.800 (45.72)	1.895 (48.13)	2.158 (54.81)																							
20	40	X	71973-2620	X	71973-2720	X	71973-2820	1.900 (48.26)	1.995 (50.67)	2.258 (57.35)																							
21	42	X	71973-2621	X	71973-2721	X	71973-2821	2.000 (50.80)	2.095 (53.21)	2.358 (59.89)																							
22	44	X	71973-2622	X	71973-2722	X	71973-2822	2.100 (53.34)	2.195 (55.75)	2.458 (62.43)																							
23	46	X	71973-2623	X	71973-2723	X	71973-2823	2.200 (55.88)	2.295 (58.29)	2.558 (64.97)																							
24	48	X	71973-2624	X	71973-2724	X	71973-2824	2.300 (58.42)	2.395 (60.83)	2.658 (67.51)																							
25	50	X	71973-2625	X	71973-2725	X	71973-2825	2.400 (60.96)	2.495 (63.37)	2.758 (70.05)																							
26	52	X	71973-2626	X	71973-2726	X	71973-2826	2.500 (63.50)	2.595 (65.91)	2.858 (72.59)																							
27	54	X	71973-2627	X	71973-2727	X	71973-2827	2.600 (66.04)	2.695 (68.45)	2.958 (75.13)																							
28	56	X	71973-2628	X	71973-2728	X	71973-2828	2.700 (68.58)	2.795 (70.99)	3.058 (77.67)																							
29	58	X	71973-2629	X	71973-2729	X	71973-2829	2.800 (71.12)	2.895 (73.53)	3.158 (80.21)																							
30	60	X	71973-2630	X	71973-2730	X	71973-2830	2.900 (73.66)	2.995 (76.07)	3.258 (82.75)																							
31	62	X	71973-2631	X	71973-2731	X	71973-2831	3.000 (76.20)	3.095 (78.61)	3.358 (85.29)																							
32	64	X	71973-2632	X	71973-2732	X	71973-2832	3.100 (78.74)	3.195 (81.15)	3.458 (87.83)																							

<p>ADD OPTION K &amp; L EC NO: S2010-0534 DRWN:SKANG 2009/12/30 CHKD:ATSEE 2010/01/08 APPR:MLONG 2010/01/14</p>	QUALITY SYMBOLS	GENERAL TOLERANCES (UNLESS SPECIFIED)	DIMENSION STYLE IN/MM	SCALE NTS	DESIGN UNITS INCH	THIRD ANGLE PROJECTION																											
	$F_A = 0$ $F_G = 0$ $F_P = 0$	<table border="1"> <tr> <th></th> <th>mm</th> <th>INCH</th> </tr> <tr> <td>4 PLACES</td> <td>± ---</td> <td>± ---</td> </tr> <tr> <td>3 PLACES</td> <td>± ---</td> <td>± .010</td> </tr> <tr> <td>2 PLACES</td> <td>± 0.25</td> <td>± ---</td> </tr> <tr> <td>1 PLACE</td> <td>± ---</td> <td>± ---</td> </tr> </table>		mm	INCH	4 PLACES	± ---	± ---	3 PLACES	± ---	± .010	2 PLACES	± 0.25	± ---	1 PLACE	± ---	± ---	<table border="1"> <tr> <th>DRAWN BY</th> <th>DATE</th> </tr> <tr> <td>DJB</td> <td>1991/10/21</td> </tr> <tr> <th>CHECKED BY</th> <th>DATE</th> </tr> <tr> <td>DJB</td> <td>1991/10/21</td> </tr> <tr> <th>APPROVED BY</th> <th>DATE</th> </tr> <tr> <td>MLONG</td> <td>2010/01/14</td> </tr> </table>	DRAWN BY	DATE	DJB	1991/10/21	CHECKED BY	DATE	DJB	1991/10/21	APPROVED BY	DATE	MLONG	2010/01/14	TITLE		
		mm	INCH																														
	4 PLACES	± ---	± ---																														
3 PLACES	± ---	± .010																															
2 PLACES	± 0.25	± ---																															
1 PLACE	± ---	± ---																															
DRAWN BY	DATE																																
DJB	1991/10/21																																
CHECKED BY	DATE																																
DJB	1991/10/21																																
APPROVED BY	DATE																																
MLONG	2010/01/14																																
	DRAFT WHERE APPLICABLE MUST REMAIN WITHIN DIMENSIONS	SEE TABLE	ANGULAR ± 1/2°	MATERIAL NO.	DOCUMENT NO.	SHEET NO.																											

NO. OF CKTS		OPTION C ASSEMBLY PACKAGED IN TRAYS PER PK-70873-0239 (SEE SHEET 1 FOR FINISH SPECIFICATIONS)					DIMENSION			
PER ROW	TOTAL				A	B				
		15 GOLD	30 GOLD	50 GOLD						
4	8	71973-7404	71973-7504	71973-7604	.300 (7.62)	.395 (10.03)				
5	10	71973-7405	71973-7505	71973-7605	.400 (10.16)	.495 (12.57)				
6	12	71973-7406	71973-7506	71973-7606	.500 (12.70)	.595 (15.11)				
7	14	71973-7407	71973-7507	71973-7607	.600 (15.24)	.695 (17.65)				
8	16	71973-7408	71973-7508	71973-7608	.700 (17.78)	.795 (20.19)				
9	18	71973-7409	71973-7509	71973-7609	.800 (20.32)	.895 (22.73)				
10	20	71973-7410	71973-7510	71973-7610	.900 (22.86)	.995 (25.27)				
11	22	71973-7411	71973-7511	71973-7611	1.000 (25.40)	1.095 (27.81)				
12	24	71973-7412	71973-7512	71973-7612	1.100 (27.94)	1.195 (30.35)				
13	26	71973-7413	71973-7513	71973-7613	1.200 (30.48)	1.295 (32.89)				
14	28	71973-7414	71973-7514	71973-7614	1.300 (33.02)	1.395 (35.43)				
15	30	71973-7415	71973-7515	71973-7615	1.400 (35.56)	1.495 (37.97)				
16	32	71973-7416	71973-7516	71973-7616	1.500 (38.10)	1.595 (40.51)				
17	34	71973-7417	71973-7517	71973-7617	1.600 (40.64)	1.695 (43.05)				
18	36	71973-7418	71973-7518	71973-7618	1.700 (43.18)	1.795 (45.59)				
19	38	71973-7419	71973-7519	71973-7619	1.800 (45.72)	1.895 (48.13)				
20	40	71973-7420	71973-7520	71973-7620	1.900 (48.26)	1.995 (50.67)				
21	42	71973-7421	71973-7521	71973-7621	2.000 (50.80)	2.095 (53.21)				
22	44	71973-7422	71973-7522	71973-7622	2.100 (53.34)	2.195 (55.75)				
23	46	71973-7423	71973-7523	71973-7623	2.200 (55.88)	2.295 (58.29)				
24	48	71973-7424	71973-7524	71973-7624	2.300 (58.42)	2.395 (60.83)				
25	50	71973-7425	71973-7525	71973-7625	2.400 (60.96)	2.495 (63.37)				
26	52	71973-7426	71973-7526	71973-7626	2.500 (63.50)	2.595 (65.91)				
27	54	71973-7427	71973-7527	71973-7627	2.600 (66.04)	2.695 (68.45)				
28	56	71973-7428	71973-7528	71973-7628	2.700 (68.58)	2.795 (70.99)				
29	58	71973-7429	71973-7529	71973-7629	2.800 (71.12)	2.895 (73.53)				
30	60	71973-7430	71973-7530	71973-7630	2.900 (73.66)	2.995 (76.07)				
31	62	71973-7431	71973-7531	71973-7631	3.000 (76.20)	3.095 (78.61)				
32	64	71973-7432	71973-7532	71973-7632	3.100 (78.74)	3.195 (81.15)				

NO. OF CKTS		OPTION C ASSEMBLY PACKAGED IN TRAYS PER PK-70873-0239 (SEE SHEET 1 FOR FINISH SPECIFICATIONS)					DIMENSION			
PER ROW	TOTAL				A	B				
		15 GOLD	30 GOLD	50 GOLD						
33	66	71973-7433	71973-7533	71973-7633	3.200 (81.28)	3.295 (83.69)				
34	68	71973-7434	71973-7534	71973-7634	3.300 (83.82)	3.395 (86.23)				
35	70	71973-7435	71973-7535	71973-7635	3.400 (86.36)	3.495 (88.77)				
36	72	71973-7436	71973-7536	71973-7636	3.500 (88.90)	3.595 (91.31)				

<b>ADD OPTION K &amp; L</b> EC NO: S2010-0534 DRWN:SKANG 2009/12/30 CHKD:ATSEE 2010/01/08 APPR:MLONG 2010/01/14 K	QUALITY SYMBOLS $F_A=0$ $F_G=0$ $F_P=0$	GENERAL TOLERANCES (UNLESS SPECIFIED) DIMENSION STYLE IN/MM SCALE NTS DESIGN UNITS INCH THIRD ANGLE PROJECTION	DRAWN BY DJB DATE 1991/10/21 CHECKED BY DJB DATE 1991/10/21 APPROVED BY MLONG DATE 2010/01/14 MATERIAL NO. SEE TABLE DOCUMENT NO. SDA-71973-**** SHEET NO. 14 OF 26	TITLE <b>EARLY ENTRY R/A RECPT .120"PC TAIL W/O LOWER ROW PINSTOP-.100" GRID</b> <b>MOLEX INCORPORATED</b>
		4 PLACES ± --- ± --- 3 PLACES ± --- ± .010 2 PLACES ± 0.25 ± --- 1 PLACE ± --- ± --- ANGULAR ± 1/2°	DRAFT WHERE APPLICABLE MUST REMAIN WITHIN DIMENSIONS	THIS DRAWING CONTAINS INFORMATION THAT IS PROPRIETARY TO MOLEX INCORPORATED AND SHOULD NOT BE USED WITHOUT WRITTEN PERMISSION
		SIZE A3	REV	REV
		REV	REV	REV

10		9		8		7		6		5		4		3		2		1											
NO. OF CKTS		OPTION D ASSEMBLY PACKAGED IN TRAYS PER PK-70873-0239 (SEE SHEET I FOR FINISH SPECIFICATIONS)						DIMENSION				NO. OF CKTS		OPTION D ASSEMBLY PACKAGED IN TRAYS PER PK-70873-0239 (SEE SHEET I FOR FINISH SPECIFICATIONS)						DIMENSION									
PER ROW	TOTAL	15 GOLD		30 GOLD		50 GOLD		A	B			D	PER ROW	TOTAL	15 GOLD		30 GOLD		50 GOLD		A	B			D				
4	8			71973-7804	71973-7904	71973-8004	.300 (7.62)	.395 (10.03)			.658 (16.71)	33	66			71973-7833	71973-7933	71973-8033						3.200 (81.28)	3.295 (83.69)			3.558 (90.37)	
5	10			71973-7805	71973-7905	71973-8005	.400 (10.16)	.495 (12.57)			.758 (19.25)	34	68			71973-7834	71973-7934	71973-8034						3.300 (83.82)	3.395 (86.23)			3.658 (92.91)	
6	12			71973-7806	71973-7906	71973-8006	.500 (12.70)	.595 (15.11)			.858 (21.79)	35	70			71973-7835	71973-7935	71973-8035						3.400 (86.36)	3.495 (88.77)			3.758 (95.45)	
7	14			71973-7807	71973-7907	71973-8007	.600 (15.24)	.695 (17.65)			.958 (24.33)	36	72			71973-7836	71973-7936	71973-8036						3.500 (88.90)	3.595 (91.31)			3.858 (97.99)	
8	16			71973-7808	71973-7908	71973-8008	.700 (17.78)	.795 (20.19)			1.058 (26.87)																		
9	18			71973-7809	71973-7909	71973-8009	.800 (20.32)	.895 (22.73)			1.158 (29.41)																		
10	20			71973-7810	71973-7910	71973-8010	.900 (22.86)	.995 (25.27)			1.258 (31.95)																		
11	22			71973-7811	71973-7911	71973-8011	1.000 (25.40)	1.095 (27.81)			1.358 (34.49)																		
12	24			71973-7812	71973-7912	71973-8012	1.100 (27.94)	1.195 (30.35)			1.458 (37.03)																		
13	26			71973-7813	71973-7913	71973-8013	1.200 (30.48)	1.295 (32.89)			1.558 (39.57)																		
14	28			71973-7814	71973-7914	71973-8014	1.300 (33.02)	1.395 (35.43)			1.658 (42.11)																		
15	30			71973-7815	71973-7915	71973-8015	1.400 (35.56)	1.495 (37.97)			1.758 (44.65)																		
16	32			71973-7816	71973-7916	71973-8016	1.500 (38.10)	1.595 (40.51)			1.858 (47.19)																		
17	34			71973-7817	71973-7917	71973-8017	1.600 (40.64)	1.695 (43.05)			1.958 (49.73)																		
18	36			71973-7818	71973-7918	71973-8018	1.700 (43.18)	1.795 (45.59)			2.058 (52.27)																		
19	38			71973-7819	71973-7919	71973-8019	1.800 (45.72)	1.895 (48.13)			2.158 (54.81)																		
20	40			71973-7820	71973-7920	71973-8020	1.900 (48.26)	1.995 (50.67)			2.258 (57.35)																		
21	42			71973-7821	71973-7921	71973-8021	2.000 (50.80)	2.095 (53.21)			2.358 (59.89)																		
22	44			71973-7822	71973-7922	71973-8022	2.100 (53.34)	2.195 (55.75)			2.458 (62.43)																		
23	46			71973-7823	71973-7923	71973-8023	2.200 (55.88)	2.295 (58.29)			2.558 (64.97)																		
24	48			71973-7824	71973-7924	71973-8024	2.300 (58.42)	2.395 (60.83)			2.658 (67.51)																		
25	50			71973-7825	71973-7925	71973-8025	2.400 (60.96)	2.495 (63.37)			2.758 (70.05)																		
26	52			71973-7826	71973-7926	71973-8026	2.500 (63.50)	2.595 (65.91)			2.858 (72.59)																		
27	54			71973-7827	71973-7927	71973-8027	2.600 (66.04)	2.695 (68.45)			2.958 (75.13)																		
28	56			71973-7828	71973-7928	71973-8028	2.700 (68.58)	2.795 (70.99)			3.058 (77.67)																		
29	58			71973-7829	71973-7929	71973-8029	2.800 (71.12)	2.895 (73.53)			3.158 (80.21)																		
30	60			71973-7830	71973-7930	71973-8030	2.900 (73.66)	2.995 (76.07)			3.258 (82.75)																		
31	62			71973-7831	71973-7931	71973-8031	3.000 (76.20)	3.095 (78.61)			3.358 (85.29)																		
32	64			71973-7832	71973-7932	71973-8032	3.100 (78.74)	3.195 (81.15)			3.458 (87.83)																		

<b>ADD OPTION K &amp; L</b> EC NO: S2010-0534 DRWN:SKANG 2009/12/30 CHKD:ATSEE 2010/01/08 APPR:MLONG 2010/01/14	QUALITY SYMBOLS	GENERAL TOLERANCES (UNLESS SPECIFIED)	DIMENSION STYLE	SCALE	DESIGN UNITS	THIRD ANGLE PROJECTION	
	$F_A = 0$ $F_G = 0$ $F_P = 0$	mm    INCH 4 PLACES ± --- ± --- 3 PLACES ± --- ± .010 2 PLACES ± 0.25 ± --- 1 PLACE ± --- ± --- ANGULAR ± 1/2°	IN/MM DRAWN BY: DJB    DATE: 1991/10/21 CHECKED BY: DJB    DATE: 1991/10/21 APPROVED BY: MLONG    DATE: 2010/01/14	NTS TITLE: EARLY ENTRY R/A RECPT .120"PC TAIL W/O LOWER ROW PINSTOP-.100" GRID	INCH MOLEX INCORPORATED		SHEET NO. 15 OF 26
	DRAFT WHERE APPLICABLE MUST REMAIN WITHIN DIMENSIONS	SEE TABLE	MATERIAL NO.	DOCUMENT NO.	SDA-71973-****		
	SIZE A3	THIS DRAWING CONTAINS INFORMATION THAT IS PROPRIETARY TO MOLEX INCORPORATED AND SHOULD NOT BE USED WITHOUT WRITTEN PERMISSION					

10		9		8		7		6		5		4		3		2		1											
NO. OF CKTS		OPTION E ASSEMBLY PACKAGED IN TUBES PER PK-70873-0138 (SEE SHEET I FOR FINISH SPECIFICATIONS)						DIMENSION				NO. OF CKTS		OPTION E ASSEMBLY PACKAGED IN TUBES PER PK-70873-0138 (SEE SHEET I FOR FINISH SPECIFICATIONS)						DIMENSION									
PER ROW	TOTAL	15 GOLD		30 GOLD		50 GOLD		A	B					15 GOLD		30 GOLD		50 GOLD		A	B								
4	8			71973-3404	71973-3504	71973-3604	.300 (7.62)	.395 (10.03)							71973-3434	71973-3534	71973-3634	3.300 (83.82)	3.395 (86.23)										
5	10			71973-3405	71973-3505	71973-3605	.400 (10.16)	.495 (12.57)							71973-3435	71973-3535	71973-3635	3.400 (86.36)	3.495 (88.77)										
6	12			71973-3406	71973-3506	71973-3606	.500 (12.70)	.595 (15.11)							71973-3436	71973-3536	71973-3636	3.500 (88.90)	3.595 (91.31)										
7	14			71973-3407	71973-3507	71973-3607	.600 (15.24)	.695 (17.65)																					
8	16			71973-3408	71973-3508	71973-3608	.700 (17.78)	.795 (20.19)																					
9	18			71973-3409	71973-3509	71973-3609	.800 (20.32)	.895 (22.73)																					
10	20			71973-3410	71973-3510	71973-3610	.900 (22.86)	.995 (25.27)																					
11	22			71973-3411	71973-3511	71973-3611	1.000 (25.40)	1.095 (27.81)																					
12	24			71973-3412	71973-3512	71973-3612	1.100 (27.94)	1.195 (30.35)																					
13	26			71973-3413	71973-3513	71973-3613	1.200 (30.48)	1.295 (32.89)																					
14	28			71973-3414	71973-3514	71973-3614	1.300 (33.02)	1.395 (35.43)																					
15	30			71973-3415	71973-3515	71973-3615	1.400 (35.56)	1.495 (37.97)																					
16	32			71973-3416	71973-3516	71973-3616	1.500 (38.10)	1.595 (40.51)																					
17	34			71973-3417	71973-3517	71973-3617	1.600 (40.64)	1.695 (43.05)																					
18	36			71973-3418	71973-3518	71973-3618	1.700 (43.18)	1.795 (45.59)																					
19	38			71973-3419	71973-3519	71973-3619	1.800 (45.72)	1.895 (48.13)																					
20	40			71973-3420	71973-3520	71973-3620	1.900 (48.26)	1.995 (50.67)																					
21	42			71973-3421	71973-3521	71973-3621	2.000 (50.80)	2.095 (53.21)																					
22	44			71973-3422	71973-3522	71973-3622	2.100 (53.34)	2.195 (55.75)																					
23	46			71973-3423	71973-3523	71973-3623	2.200 (55.88)	2.295 (58.29)																					
24	48			71973-3424	71973-3524	71973-3624	2.300 (58.42)	2.395 (60.83)																					
25	50			71973-3425	71973-3525	71973-3625	2.400 (60.96)	2.495 (63.37)																					
26	52			71973-3426	71973-3526	71973-3626	2.500 (63.50)	2.595 (65.91)																					
27	54			71973-3427	71973-3527	71973-3627	2.600 (66.04)	2.695 (68.45)																					
28	56			71973-3428	71973-3528	71973-3628	2.700 (68.58)	2.795 (70.99)																					
29	58			71973-3429	71973-3529	71973-3629	2.800 (71.12)	2.895 (73.53)																					
30	60			71973-3430	71973-3530	71973-3630	2.900 (73.66)	2.995 (76.07)																					
31	62			71973-3431	71973-3531	71973-3631	3.000 (76.20)	3.095 (78.61)																					
32	64			71973-3432	71973-3532	71973-3632	3.100 (78.74)	3.195 (81.15)																					
33	66			71973-3433	71973-3533	71973-3633	3.200 (81.28)	3.295 (83.69)																					

ADD OPTION K & L EC NO: S2010-0534 DRWN:SKANG CHKD:ATSEE APPR:MLONG 2009/12/30 2010/01/08 2010/01/14	QUALITY SYMBOLS	GENERAL TOLERANCES (UNLESS SPECIFIED)	DIMENSION STYLE	SCALE	DESIGN UNITS	THIRD ANGLE PROJECTION
	$F_A = 0$ $F_G = 0$ $F_P = 0$	4 PLACES ± --- ± --- 3 PLACES ± --- ± .010 2 PLACES ± 0.25 ± --- 1 PLACE ± --- ± --- ANGULAR ± 1/2°	IN/MM	NTS	INCH	<input checked="" type="checkbox"/> THIRD ANGLE PROJECTION
	DRAWN BY: DJB CHECKED BY: DJB APPROVED BY: MLONG	DATE: 1991/10/21 DATE: 1991/10/21 DATE: 2010/01/14	TITLE	EARLY ENTRY R/A RECPT .120"PC TAIL W/O LOWER ROW PINSTOP-.100" GRID MOLEX INCORPORATED		
	MATERIAL NO. SEE TABLE SIZE A3 DRAFT WHERE APPLICABLE MUST REMAIN WITHIN DIMENSIONS	DOCUMENT NO. SDA-71973-**** SHEET NO. 16 OF 26 THIS DRAWING CONTAINS INFORMATION THAT IS PROPRIETARY TO MOLEX INCORPORATED AND SHOULD NOT BE USED WITHOUT WRITTEN PERMISSION				





NO. OF CKTS		OPTION E ASSEMBLY PACKAGED IN TRAYS PER PK-70873-0239 (SEE SHEET I FOR FINISH SPECIFICATIONS)					DIMENSION		NO. OF CKTS		OPTION E ASSEMBLY PACKAGED IN TRAYS PER PK-70873-0239 (SEE SHEET I FOR FINISH SPECIFICATIONS)					DIMENSION	
PER ROW	TOTAL	15 GOLD	30 GOLD	50 GOLD	A	B	PER ROW	TOTAL	15 GOLD	30 GOLD	50 GOLD	A	B				
4	8	71973-8204	71973-8304	71973-8404	.300 (7.62)	.395 (10.03)	34	68	71973-8234	71973-8334	71973-8434	3.300 (83.82)	3.395 (86.23)				
5	10	71973-8205	71973-8305	71973-8405	.400 (10.16)	.495 (12.57)	35	70	71973-8235	71973-8335	71973-8435	3.400 (86.36)	3.495 (88.77)				
6	12	71973-8206	71973-8306	71973-8406	.500 (12.70)	.595 (15.11)	36	72	71973-8236	71973-8336	71973-8436	3.500 (88.90)	3.595 (91.31)				
7	14	71973-8207	71973-8307	71973-8407	.600 (15.24)	.695 (17.65)											
8	16	71973-8208	71973-8308	71973-8408	.700 (17.78)	.795 (20.19)											
9	18	71973-8209	71973-8309	71973-8409	.800 (20.32)	.895 (22.73)											
10	20	71973-8210	71973-8310	71973-8410	.900 (22.86)	.995 (25.27)											
11	22	71973-8211	71973-8311	71973-8411	1.000 (25.40)	1.095 (27.81)											
12	24	71973-8212	71973-8312	71973-8412	1.100 (27.94)	1.195 (30.35)											
13	26	71973-8213	71973-8313	71973-8413	1.200 (30.48)	1.295 (32.89)											
14	28	71973-8214	71973-8314	71973-8414	1.300 (33.02)	1.395 (35.43)											
15	30	71973-8215	71973-8315	71973-8415	1.400 (35.56)	1.495 (37.97)											
16	32	71973-8216	71973-8316	71973-8416	1.500 (38.10)	1.595 (40.51)											
17	34	71973-8217	71973-8317	71973-8417	1.600 (40.64)	1.695 (43.05)											
18	36	71973-8218	71973-8318	71973-8418	1.700 (43.18)	1.795 (45.59)											
19	38	71973-8219	71973-8319	71973-8419	1.800 (45.72)	1.895 (48.13)											
20	40	71973-8220	71973-8320	71973-8420	1.900 (48.26)	1.995 (50.67)											
21	42	71973-8221	71973-8321	71973-8421	2.000 (50.80)	2.095 (53.21)											
22	44	71973-8222	71973-8322	71973-8422	2.100 (53.34)	2.195 (55.75)											
23	46	71973-8223	71973-8323	71973-8423	2.200 (55.88)	2.295 (58.29)											
24	48	71973-8224	71973-8324	71973-8424	2.300 (58.42)	2.395 (60.83)											
25	50	71973-8225	71973-8325	71973-8425	2.400 (60.96)	2.495 (63.37)											
26	52	71973-8226	71973-8326	71973-8426	2.500 (63.50)	2.595 (65.91)											
27	54	71973-8227	71973-8327	71973-8427	2.600 (66.04)	2.695 (68.45)											
28	56	71973-8228	71973-8328	71973-8428	2.700 (68.58)	2.795 (70.99)											
29	58	71973-8229	71973-8329	71973-8429	2.800 (71.12)	2.895 (73.53)											
30	60	71973-8230	71973-8330	71973-8430	2.900 (73.66)	2.995 (76.07)											
31	62	71973-8231	71973-8331	71973-8431	3.000 (76.20)	3.095 (78.61)											
32	64	71973-8232	71973-8332	71973-8432	3.100 (78.74)	3.195 (81.15)											
33	66	71973-8233	71973-8333	71973-8433	3.200 (81.28)	3.295 (83.69)											

*X INDICATES TOOLING IS NOT AVAILABLE.  ADD OPTION K & L EC NO: S2010-0534 DRWN:SKANG CHKD:ATSEE APPR:MLONG 2009/12/30 2010/01/08 2010/01/14	QUALITY SYMBOLS $F_A=0$ $F_B=0$ $F_P=0$	GENERAL TOLERANCES (UNLESS SPECIFIED) mm INCH 4 PLACES ± --- ± --- 3 PLACES ± --- ± .010 2 PLACES ± 0.25 ± --- 1 PLACE ± --- ± --- ANGULAR ± 1/2°	DIMENSION STYLE IN/MM DRAWN BY DATE DJB 1991/10/21 CHECKED BY DATE DJB 1991/10/21 APPROVED BY DATE MLONG 2010/01/14	SCALE NTS DESIGN UNITS INCH THIRD ANGLE PROJECTION	TITLE EARLY ENTRY R/A RECPT .120"PC TAIL W/O LOWER ROW PINSTOP-.100" GRID MOLEX INCORPORATED DOCUMENT NO. SDA-71973-****	SHEET NO. 18 OF 26
	DRAFT WHERE APPLICABLE MUST REMAIN WITHIN DIMENSIONS	SEE TABLE	THIS DRAWING CONTAINS INFORMATION THAT IS PROPRIETARY TO MOLEX INCORPORATED AND SHOULD NOT BE USED WITHOUT WRITTEN PERMISSION			
	SIZE A3					

NO. OF CKTS		OPTION F ASSEMBLY PACKAGED IN TRAYS PER PK-70873-0239 (SEE SHEET I FOR FINISH SPECIFICATIONS)					DIMENSION				NO. OF CKTS		OPTION F ASSEMBLY PACKAGED IN TRAYS PER PK-70873-0239 (SEE SHEET I FOR FINISH SPECIFICATIONS)					DIMENSION				
PER ROW	TOTAL	15 GOLD			30 GOLD	50 GOLD	A	B	D		PER ROW	TOTAL	15 GOLD			30 GOLD	50 GOLD	A	B	D		
4	8			71973-8604	71973-8704	71973-8804	.300 (16.71)	.395 (10.03)		.658 (16.71)	34	68			71973-8634	71973-8734	71973-8834	3.300 (83.82)	3.395 (86.23)		3.658 (92.91)	
5	10			71973-8605	71973-8705	71973-8805	.400 (10.16)	.495 (12.57)		.758 (19.25)	35	70			71973-8635	71973-8735	71973-8835	3.400 (86.36)	3.495 (88.77)		3.758 (95.45)	
6	12			71973-8606	71973-8706	71973-8806	.500 (12.70)	.595 (15.11)		.858 (21.79)	36	72			71973-8636	71973-8736	71973-8836	3.500 (88.90)	3.595 (91.31)		3.858 (97.99)	
7	14			71973-8607	71973-8707	71973-8807	.600 (15.24)	.695 (17.65)		.958 (24.33)												
8	16			71973-8608	71973-8708	71973-8808	.700 (17.78)	.795 (20.19)		1.058 (26.87)												
9	18			71973-8609	71973-8709	71973-8809	.800 (20.32)	.895 (22.73)		1.158 (29.41)												
10	20			71973-8610	71973-8710	71973-8810	.900 (22.86)	.995 (25.27)		1.258 (31.95)												
11	22			71973-8611	71973-8711	71973-8811	1.000 (25.40)	1.095 (27.81)		1.358 (34.49)												
12	24			71973-8612	71973-8712	71973-8812	1.100 (27.94)	1.195 (30.35)		1.458 (37.03)												
13	26			71973-8613	71973-8713	71973-8813	1.200 (30.48)	1.295 (32.89)		1.558 (39.57)												
14	28			71973-8614	71973-8714	71973-8814	1.300 (33.02)	1.395 (35.43)		1.658 (42.11)												
15	30			71973-8615	71973-8715	71973-8815	1.400 (35.56)	1.495 (37.97)		1.758 (44.65)												
16	32			71973-8616	71973-8716	71973-8816	1.500 (38.10)	1.595 (40.51)		1.858 (47.19)												
17	34			71973-8617	71973-8717	71973-8817	1.600 (40.64)	1.695 (43.05)		1.958 (49.73)												
18	36			71973-8618	71973-8718	71973-8818	1.700 (43.18)	1.795 (45.59)		2.058 (52.27)												
19	38			71973-8619	71973-8719	71973-8819	1.800 (45.72)	1.895 (48.13)		2.158 (54.81)												
20	40			71973-8620	71973-8720	71973-8820	1.900 (48.26)	1.995 (50.67)		2.258 (57.35)												
21	42			71973-8621	71973-8721	71973-8821	2.000 (50.80)	2.095 (53.21)		2.358 (59.89)												
22	44			71973-8622	71973-8722	71973-8822	2.100 (53.34)	2.195 (55.75)		2.458 (62.43)												
23	46			71973-8623	71973-8723	71973-8823	2.200 (55.88)	2.295 (58.29)		2.558 (64.97)												
24	48			71973-8624	71973-8724	71973-8824	2.300 (58.42)	2.395 (60.83)		2.658 (67.51)												
25	50			71973-8625	71973-8725	71973-8825	2.400 (60.96)	2.495 (63.37)		2.758 (70.05)												
26	52			71973-8626	71973-8726	71973-8826	2.500 (63.50)	2.595 (65.91)		2.858 (72.59)												
27	54			71973-8627	71973-8727	71973-8827	2.600 (66.04)	2.695 (68.45)		2.958 (75.13)												
28	56			71973-8628	71973-8728	71973-8828	2.700 (68.58)	2.795 (70.99)		3.058 (77.67)												
29	58			71973-8629	71973-8729	71973-8829	2.800 (71.12)	2.895 (73.53)		3.158 (80.21)												
30	60			71973-8630	71973-8730	71973-8830	2.900 (73.66)	2.995 (76.07)		3.258 (82.75)												
31	62			71973-8631	71973-8731	71973-8831	3.000 (76.20)	3.095 (78.61)		3.358 (85.29)												
32	64			71973-8632	71973-8732	71973-8832	3.100 (78.74)	3.195 (81.15)		3.458 (87.83)												
33	66			71973-8633	71973-8733	71973-8833	3.200 (81.28)	3.295 (83.69)		3.558 (90.37)												

\*X\* INDICATES TOOLING IS NOT AVAILABLE.

ADD OPTION K & L  
 EC NO: S2010-0534  
 DRWN:SKANG 2009/12/30  
 CHKD:ATSEE 2010/01/08  
 APPR:MLONG 2010/01/14

QUALITY SYMBOLS  
 $F_A=0$   
 $F_B=0$   
 $F_C=0$

DRAFT WHERE APPLICABLE  
 MUST REMAIN  
 WITHIN DIMENSIONS

GENERAL TOLERANCES  
 (UNLESS SPECIFIED)

	mm	INCH
4 PLACES	± ---	± ---
3 PLACES	± ---	± .010
2 PLACES	± 0.25	± ---
1 PLACE	± ---	± ---

ANGULAR ± 1/2°

DIMENSION STYLE  
 IN/MM

SCALE  
 NTS

DESIGN UNITS  
 INCH

THIRD ANGLE  
 PROJECTION

TITLE  
 EARLY ENTRY R/A RECPT  
 .120"PC TAIL W/O LOWER  
 ROW PINSTOP-.100" GRID

MOLEX MOLEX INCORPORATED

MATERIAL NO.  
 SEE TABLE

DOCUMENT NO.  
 SDA-71973-\*\*\*\*

SHEET NO.  
 19 OF 26

THIS DRAWING CONTAINS INFORMATION THAT IS PROPRIETARY TO MOLEX  
 INCORPORATED AND SHOULD NOT BE USED WITHOUT WRITTEN PERMISSION



10		9			8			7			6			5			4			3			2			1			
NO. OF CKTS		OPTION H ASSEMBLY PACKAGED IN TUBES PER PK-70873-0139 (SEE SHEET I FOR FINISH SPECIFICATIONS)									DIMENSION				NO. OF CKTS		OPTION H ASSEMBLY PACKAGED IN TUBES PER PK-70873-0139 (SEE SHEET I FOR FINISH SPECIFICATIONS)									DIMENSION			
PER ROW	TOTAL	15 GOLD			30 GOLD			50 GOLD			A	B		D	PER ROW	TOTAL	15 GOLD			30 GOLD			50 GOLD			A	B		D
4	8	X	71973-5804	X	71973-5904	X	71973-6004	.300 (7.62)	.395 (10.03)			.658 (16.71)	31	62	X	71973-5831	X	71973-5931	X	71973-6031	3.000 (76.20)	3.095 (78.61)			3.358 (85.29)				
5	10	X	71973-5805	X	71973-5905	X	71973-6005	.400 (10.16)	.495 (12.57)			.758 (19.25)	32	64	X	71973-5832	X	71973-5932	X	71973-6032	3.100 (78.74)	3.195 (81.15)			3.458 (87.83)				
6	12	X	71973-5806	X	71973-5906	X	71973-6006	.500 (12.70)	.595 (15.11)			.858 (21.79)	33	66	X	71973-5833	X	71973-5933	X	71973-6033	3.200 (81.28)	3.295 (83.69)			3.558 (90.37)				
7	14	X	71973-5807	X	71973-5907	X	71973-6007	.600 (15.24)	.695 (17.65)			.958 (24.33)	34	68	X	71973-5834	X	71973-5934	X	71973-6034	3.300 (83.82)	3.395 (86.23)			3.658 (92.91)				
8	16	X	71973-5808	X	71973-5908	X	71973-6008	.700 (17.78)	.795 (20.19)			1.058 (26.87)	35	70	X	71973-5835	X	71973-5935	X	71973-6035	3.400 (86.36)	3.495 (88.77)			3.758 (95.45)				
9	18	X	71973-5809	X	71973-5909	X	71973-6009	.800 (20.32)	.895 (22.73)			1.158 (29.41)	36	72	X	71973-5836	X	71973-5936	X	71973-6036	3.500 (88.90)	3.595 (91.31)			3.858 (97.99)				
10	20	X	71973-5810	X	71973-5910	X	71973-6010	.900 (22.86)	.995 (25.27)			1.258 (31.95)																	
11	22	X	71973-5811	X	71973-5911	X	71973-6011	1.000 (25.40)	1.095 (27.81)			1.358 (34.49)																	
12	24	X	71973-5812	X	71973-5912	X	71973-6012	1.100 (27.94)	1.195 (30.35)			1.458 (37.03)																	
13	26	X	71973-5813	X	71973-5913	X	71973-6013	1.200 (30.48)	1.295 (32.89)			1.558 (39.57)																	
14	28	X	71973-5814	X	71973-5914	X	71973-6014	1.300 (33.02)	1.395 (35.43)			1.658 (42.11)																	
15	30	X	71973-5815	X	71973-5915	X	71973-6015	1.400 (35.56)	1.495 (37.97)			1.758 (44.65)																	
16	32	X	71973-5816	X	71973-5916	X	71973-6016	1.500 (38.10)	1.595 (40.51)			1.858 (47.19)																	
17	34	X	71973-5817	X	71973-5917	X	71973-6017	1.600 (40.64)	1.695 (43.05)			1.958 (49.73)																	
18	36	X	71973-5818	X	71973-5918	X	71973-6018	1.700 (43.18)	1.795 (45.59)			2.058 (52.27)																	
19	38	X	71973-5819	X	71973-5919	X	71973-6019	1.800 (45.72)	1.895 (48.13)			2.158 (54.81)																	
20	40	X	71973-5820	X	71973-5920	X	71973-6020	1.900 (48.26)	1.995 (50.67)			2.258 (57.35)																	
21	42	X	71973-5821	X	71973-5921	X	71973-6021	2.000 (50.80)	2.095 (53.21)			2.358 (59.89)																	
22	44	X	71973-5822	X	71973-5922	X	71973-6022	2.100 (53.34)	2.195 (55.75)			2.458 (62.43)																	
23	46	X	71973-5823	X	71973-5923	X	71973-6023	2.200 (55.88)	2.295 (58.29)			2.558 (64.97)																	
24	48	X	71973-5824	X	71973-5924	X	71973-6024	2.300 (58.42)	2.395 (60.83)			2.658 (67.51)																	
25	50	X	71973-5825	X	71973-5925	X	71973-6025	2.400 (60.96)	2.495 (63.37)			2.758 (70.05)																	
26	52	X	71973-5826	X	71973-5926	X	71973-6026	2.500 (63.50)	2.595 (65.91)			2.858 (72.59)																	
27	54	X	71973-5827	X	71973-5927	X	71973-6027	2.600 (66.04)	2.695 (68.45)			2.958 (75.13)																	
28	56	X	71973-5828	X	71973-5928	X	71973-6028	2.700 (68.58)	2.795 (70.99)			3.058 (77.67)																	
29	58	X	71973-5829	X	71973-5929	X	71973-6029	2.800 (71.12)	2.895 (73.53)			3.158 (80.21)																	
30	60	X	71973-5830	X	71973-5930	X	71973-6030	2.900 (73.66)	2.995 (76.07)			3.258 (82.75)																	

\*X INDICATES TOOLING IS NOT AVAILABLE.

<b>ADD OPTION K &amp; L</b> EC NO: S2010-0534 DRWN:SKANG CHKD:ATSEE APPR:MLONG 2009/12/30 2010/01/08 2010/01/14	QUALITY SYMBOLS
	$F_A = 0$
	$F_C = 0$
	$F_P = 0$

GENERAL TOLERANCES (UNLESS SPECIFIED)	DIMENSION STYLE	SCALE	DESIGN UNITS	THIRD ANGLE PROJECTION
	IN/MM	NTS	INCH	
	mm INCH			
4 PLACES ± --- ± ---	DRAWN BY DATE	TITLE		
3 PLACES ± --- ± .010	CHECKED BY DATE	EARLY ENTRY R/A RECPT		
2 PLACES ± 0.25 ± ---	APPROVED BY DATE	.120"PC TAIL W/O LOWER		
1 PLACE ± --- ± ---	MATERIAL NO.	ROW PINSTOP-.100" GRID		
ANGULAR ± 1/2°	SEE TABLE	MOLEX INCORPORATED		
DRAFT WHERE APPLICABLE MUST REMAIN WITHIN DIMENSIONS	SIZE A3	SDA-71973-****		
		THIS DRAWING CONTAINS INFORMATION THAT IS PROPRIETARY TO MOLEX INCORPORATED AND SHOULD NOT BE USED WITHOUT WRITTEN PERMISSION		

NO. OF CKTS		OPTION G ASSEMBLY PACKAGED IN TRAYS PER PK-70873-0239 (SEE SHEET I FOR FINISH SPECIFICATIONS)					DIMENSION				NO. OF CKTS		OPTION G ASSEMBLY PACKAGED IN TRAYS PER PK-70873-0239 (SEE SHEET I FOR FINISH SPECIFICATIONS)					DIMENSION							
PER ROW	TOTAL				15 GOLD	30 GOLD	50 GOLD	A	B				PER ROW	TOTAL				15 GOLD	30 GOLD	50 GOLD	A	B			
4	8				71973-9004	71973-9104	71973-9204	.300 (7.62)	.395 (10.03)			34	68				71973-9034	71973-9134	71973-9234	3.300 (83.82)	3.395 (86.23)				
5	10				71973-9005	71973-9105	71973-9205	.400 (10.16)	.495 (12.57)			35	70				71973-9035	71973-9135	71973-9235	3.400 (86.36)	3.495 (88.77)				
6	12				71973-9006	71973-9106	71973-9206	.500 (12.70)	.595 (15.11)			36	72				71973-9036	71973-9136	71973-9236	3.500 (88.90)	3.595 (91.31)				
7	14				71973-9007	71973-9107	71973-9207	.600 (15.24)	.695 (17.65)																
8	16				71973-9008	71973-9108	71973-9208	.700 (17.78)	.795 (20.19)																
9	18				71973-9009	71973-9109	71973-9209	.800 (20.32)	.895 (22.73)																
10	20				71973-9010	71973-9110	71973-9210	.900 (22.86)	.995 (25.27)																
11	22				71973-9011	71973-9111	71973-9211	1.000 (25.40)	1.095 (27.81)																
12	24				71973-9012	71973-9112	71973-9212	1.100 (27.94)	1.195 (30.35)																
13	26				71973-9013	71973-9113	71973-9213	1.200 (30.48)	1.295 (32.89)																
14	28				71973-9014	71973-9114	71973-9214	1.300 (33.02)	1.395 (35.43)																
15	30				71973-9015	71973-9115	71973-9215	1.400 (35.56)	1.495 (37.97)																
16	32				71973-9016	71973-9116	71973-9216	1.500 (38.10)	1.595 (40.51)																
17	34				71973-9017	71973-9117	71973-9217	1.600 (40.64)	1.695 (43.05)																
18	36				71973-9018	71973-9118	71973-9218	1.700 (43.18)	1.795 (45.59)																
19	38				71973-9019	71973-9119	71973-9219	1.800 (45.72)	1.895 (48.13)																
20	40				71973-9020	71973-9120	71973-9220	1.900 (48.26)	1.995 (50.67)																
21	42				71973-9021	71973-9121	71973-9221	2.000 (50.80)	2.095 (53.21)																
22	44				71973-9022	71973-9122	71973-9222	2.100 (53.34)	2.195 (55.75)																
23	46				71973-9023	71973-9123	71973-9223	2.200 (55.88)	2.295 (58.29)																
24	48				71973-9024	71973-9124	71973-9224	2.300 (58.42)	2.395 (60.83)																
25	50				71973-9025	71973-9125	71973-9225	2.400 (60.96)	2.495 (63.37)																
26	52				71973-9026	71973-9126	71973-9226	2.500 (63.50)	2.595 (65.91)																
27	54				71973-9027	71973-9127	71973-9227	2.600 (66.04)	2.695 (68.45)																
28	56				71973-9028	71973-9128	71973-9228	2.700 (68.58)	2.795 (70.99)																
29	58				71973-9029	71973-9129	71973-9229	2.800 (71.12)	2.895 (73.53)																
30	60				71973-9030	71973-9130	71973-9230	2.900 (73.66)	2.995 (76.07)																
31	62				71973-9031	71973-9131	71973-9231	3.000 (76.20)	3.095 (78.61)																
32	64				71973-9032	71973-9132	71973-9232	3.100 (78.74)	3.195 (81.15)																
33	66				71973-9033	71973-9133	71973-9233	3.200 (81.28)	3.295 (83.69)																

ADD OPTION K & L EC NO: S2010-0534 DRWN:SKANG 2009/12/30 CHKD:ATSEE 2010/01/08 APPR:MLONG 2010/01/14	QUALITY SYMBOLS	GENERAL TOLERANCES (UNLESS SPECIFIED)	DIMENSION STYLE	SCALE	DESIGN UNITS	THIRD ANGLE PROJECTION	
	$F_A = 0$ $F_G = 0$ $F_P = 0$	mm INCH 4 PLACES ± --- ± --- 3 PLACES ± --- ± .010 2 PLACES ± 0.25 ± --- 1 PLACE ± --- ± --- ANGULAR ± 1/2°	IN/MM DRAWN BY DATE DJB 1991/10/21 CHECKED BY DATE DJB 1991/10/21 APPROVED BY DATE MLONG 2010/01/14	NTS TITLE EARLY ENTRY R/A RECPT .120"PC TAIL W/O LOWER ROW PINSTOP-.100" GRID	INCH		MOLEX INCORPORATED
	DRAFT WHERE APPLICABLE MUST REMAIN WITHIN DIMENSIONS	SEE TABLE	MATERIAL NO. DOCUMENT NO. SDA-71973-****	SHEET NO. 22 OF 26	THIS DRAWING CONTAINS INFORMATION THAT IS PROPRIETARY TO MOLEX INCORPORATED AND SHOULD NOT BE USED WITHOUT WRITTEN PERMISSION		
	*X* INDICATES TOOLING IS NOT AVAILABLE						

10		9			8			7			6			5			4			3			2			1		
NO. OF CKTS		OPTION H ASSEMBLY PACKAGED IN TRAYS PER PK-70873-0239 (SEE SHEET I FOR FINISH SPECIFICATIONS)									DIMENSION			NO. OF CKTS		OPTION H ASSEMBLY PACKAGED IN TRAYS PER PK-70873-0239 (SEE SHEET I FOR FINISH SPECIFICATIONS)									DIMENSION			
PER ROW	TOTAL		15 GOLD	30 GOLD	50 GOLD	A	B		D	PER ROW	TOTAL		15 GOLD	30 GOLD	50 GOLD	A	B		D									
4	8	X	71973-9404	X	71973-9504	X	71973-9604	.300 (7.62)	.395 (10.03)	.658 (16.71)	33	66	X	71973-9433	X	71973-9533	X	71973-9633	3.200 (81.28)	3.295 (83.69)	3.558 (90.37)							
5	10	X	71973-9405	X	71973-9505	X	71973-9605	.400 (10.16)	.495 (12.57)	.758 (19.25)	34	68	X	71973-9434	X	71973-9534	X	71973-9634	3.300 (83.82)	3.395 (86.23)	3.658 (92.91)							
6	12	X	71973-9406	X	71973-9506	X	71973-9606	.500 (12.70)	.595 (15.11)	.858 (21.79)	35	70	X	71973-9435	X	71973-9535	X	71973-9635	3.400 (86.36)	3.495 (88.77)	3.758 (95.45)							
7	14	X	71973-9407	X	71973-9507	X	71973-9607	.600 (15.24)	.695 (17.65)	.958 (24.33)	36	72	X	71973-9436	X	71973-9536	X	71973-9636	3.500 (88.90)	3.595 (91.31)	3.858 (97.99)							
8	16	X	71973-9408	X	71973-9508	X	71973-9608	.700 (17.78)	.795 (20.19)	1.058 (26.87)																		
9	18	X	71973-9409	X	71973-9509	X	71973-9609	.800 (20.32)	.895 (22.73)	1.158 (29.41)																		
10	20	X	71973-9410	X	71973-9510	X	71973-9610	.900 (22.86)	.995 (25.27)	1.258 (31.95)																		
11	22	X	71973-9411	X	71973-9511	X	71973-9611	1.000 (25.40)	1.095 (27.81)	1.358 (34.49)																		
12	24	X	71973-9412	X	71973-9512	X	71973-9612	1.100 (27.94)	1.195 (30.35)	1.458 (37.03)																		
13	26	X	71973-9413	X	71973-9513	X	71973-9613	1.200 (30.48)	1.295 (32.89)	1.558 (39.57)																		
14	28	X	71973-9414	X	71973-9514	X	71973-9614	1.300 (33.02)	1.395 (35.43)	1.658 (42.11)																		
15	30	X	71973-9415	X	71973-9515	X	71973-9615	1.400 (35.56)	1.495 (37.97)	1.758 (44.65)																		
16	32	X	71973-9416	X	71973-9516	X	71973-9616	1.500 (38.10)	1.595 (40.51)	1.858 (47.19)																		
17	34	X	71973-9417	X	71973-9517	X	71973-9617	1.600 (40.64)	1.695 (43.05)	1.958 (49.73)																		
18	36	X	71973-9418	X	71973-9518	X	71973-9618	1.700 (43.18)	1.795 (45.59)	2.058 (52.27)																		
19	38	X	71973-9419	X	71973-9519	X	71973-9619	1.800 (45.72)	1.895 (48.13)	2.158 (54.81)																		
20	40	X	71973-9420	X	71973-9520	X	71973-9620	1.900 (48.26)	1.995 (50.67)	2.258 (57.35)																		
21	42	X	71973-9421	X	71973-9521	X	71973-9621	2.000 (50.80)	2.095 (53.21)	2.358 (59.89)																		
22	44	X	71973-9422	X	71973-9522	X	71973-9622	2.100 (53.34)	2.195 (55.75)	2.458 (62.43)																		
23	46	X	71973-9423	X	71973-9523	X	71973-9623	2.200 (55.88)	2.295 (58.29)	2.558 (64.97)																		
24	48	X	71973-9424	X	71973-9524	X	71973-9624	2.300 (58.42)	2.395 (60.83)	2.658 (67.51)																		
25	50	X	71973-9425	X	71973-9525	X	71973-9625	2.400 (60.96)	2.495 (63.37)	2.758 (70.05)																		
26	52	X	71973-9426	X	71973-9526	X	71973-9626	2.500 (63.50)	2.595 (65.91)	2.858 (72.59)																		
27	54	X	71973-9427	X	71973-9527	X	71973-9627	2.600 (66.04)	2.695 (68.45)	2.958 (75.13)																		
28	56	X	71973-9428	X	71973-9528	X	71973-9628	2.700 (68.58)	2.795 (70.99)	3.058 (77.67)																		
29	58	X	71973-9429	X	71973-9529	X	71973-9629	2.800 (71.12)	2.895 (73.53)	3.158 (80.21)																		
30	60	X	71973-9430	X	71973-9530	X	71973-9630	2.900 (73.66)	2.995 (76.07)	3.258 (82.75)																		
31	62	X	71973-9431	X	71973-9531	X	71973-9631	3.000 (76.20)	3.095 (78.61)	3.358 (85.29)																		
32	64	X	71973-9432	X	71973-9532	X	71973-9632	3.100 (78.74)	3.195 (81.15)	3.458 (87.83)																		

X INDICATES TOOLING IS NOT AVAILABLE		<b>ADD OPTION K &amp; L</b> EC NO: S2010-0534 DRWIN:SKANG 2009/12/30 CHKD:ATSEE 2010/01/08 APPR:MLONG 2010/01/14		QUALITY SYMBOLS $F_A=0$ $F_C=0$ $F_P=0$	GENERAL TOLERANCES (UNLESS SPECIFIED) <table border="1"> <tr> <th></th> <th>mm</th> <th>INCH</th> </tr> <tr> <td>4 PLACES</td> <td>± .005</td> <td>± .0004</td> </tr> <tr> <td>3 PLACES</td> <td>± .003</td> <td>± .0001</td> </tr> <tr> <td>2 PLACES</td> <td>± 0.25</td> <td>± .010</td> </tr> <tr> <td>1 PLACE</td> <td>± .001</td> <td>± .0001</td> </tr> </table>		mm	INCH	4 PLACES	± .005	± .0004	3 PLACES	± .003	± .0001	2 PLACES	± 0.25	± .010	1 PLACE	± .001	± .0001	DIMENSION STYLE <b>IN/MM</b> DRAWN BY: DJB DATE: 1991/10/21 CHECKED BY: DJB DATE: 1991/10/21 APPROVED BY: MLONG DATE: 2010/01/14	SCALE <b>NTS</b>	DESIGN UNITS <b>INCH</b>		THIRD ANGLE PROJECTION	TITLE <b>EARLY ENTRY R/A RECPT .120"PC TAIL W/O LOWER ROW PINSTOP-.100" GRID</b>	<b>MOLEX INCORPORATED</b>	MATERIAL NO. <b>SDA-71973-****</b>	SHEET NO. <b>23 OF 26</b>
	mm	INCH																											
4 PLACES	± .005	± .0004																											
3 PLACES	± .003	± .0001																											
2 PLACES	± 0.25	± .010																											
1 PLACE	± .001	± .0001																											
DRAFT WHERE APPLICABLE MUST REMAIN WITHIN DIMENSIONS					SEE TABLE		THIS DRAWING CONTAINS INFORMATION THAT IS PROPRIETARY TO MOLEX INCORPORATED AND SHOULD NOT BE USED WITHOUT WRITTEN PERMISSION																						

10		9		8		7		6		5		4		3		2		1	
NO. OF CKTS	PER ROW	TOTAL	OPTION I ASSEMBLY PACKAGED IN TUBES PER PK-70873-0138 (SEE SHEET I FOR FINISH SPECIFICATIONS)			DIMENSION				NO. OF CKTS	PER ROW	TOTAL	OPTION I ASSEMBLY PACKAGED IN TUBES PER PK-70873-0138 (SEE SHEET I FOR FINISH SPECIFICATIONS)			DIMENSION			
			15 GOLD	30 GOLD	50 GOLD	A	B	C	D				15 GOLD	30 GOLD	50 GOLD	A	B	C	D
4	8		71973-9704	71973-9804	71973-9904	.300 (7.62)	.395 (10.03)	.200 (5.08)	.658 (16.71)	34	68		71973-9734	71973-9834	71973-9934	3.300 (83.82)	3.395 (86.23)	3.200 (81.28)	3.658 (92.91)
5	10		71973-9705	71973-9805	71973-9905	.400 (10.16)	.495 (12.57)	.300 (7.62)	.758 (19.25)	35	70		71973-9735	71973-9835	71973-9935	3.400 (86.36)	3.495 (88.77)	3.300 (83.82)	3.758 (95.45)
6	12		71973-9706	71973-9806	71973-9906	.500 (12.70)	.595 (15.11)	.400 (10.16)	.858 (21.79)	36	72		71973-9736	71973-9836	71973-9936	3.500 (88.90)	3.595 (91.31)	3.400 (86.36)	3.858 (97.99)
7	14		71973-9707	71973-9807	71973-9907	.600 (15.24)	.695 (17.65)	.500 (12.70)	.958 (24.33)										
8	16		71973-9708	71973-9808	71973-9908	.700 (17.78)	.795 (20.19)	.600 (15.24)	1.058 (26.87)										
9	18		71973-9709	71973-9809	71973-9909	.800 (20.32)	.895 (22.73)	.700 (17.78)	1.158 (29.41)										
10	20		71973-9710	71973-9810	71973-9910	.900 (22.86)	.995 (25.27)	.800 (20.32)	1.258 (31.95)										
11	22		71973-9711	71973-9811	71973-9911	1.000 (25.40)	1.095 (27.81)	.900 (22.86)	1.358 (34.49)										
12	24		71973-9712	71973-9812	71973-9912	1.100 (27.94)	1.195 (30.35)	1.000 (25.40)	1.458 (37.03)										
13	26		71973-9713	71973-9813	71973-9913	1.200 (30.48)	1.295 (32.89)	1.100 (27.94)	1.558 (39.57)										
14	28		71973-9714	71973-9814	71973-9914	1.300 (33.02)	1.395 (35.43)	1.200 (30.48)	1.658 (42.11)										
15	30		71973-9715	71973-9815	71973-9915	1.400 (35.56)	1.495 (37.97)	1.300 (33.02)	1.758 (44.65)										
16	32		71973-9716	71973-9816	71973-9916	1.500 (38.10)	1.595 (40.51)	1.400 (35.56)	1.858 (47.19)										
17	34		71973-9717	71973-9817	71973-9917	1.600 (40.64)	1.695 (43.05)	1.500 (38.10)	1.958 (49.73)										
18	36		71973-9718	71973-9818	71973-9918	1.700 (43.18)	1.795 (45.59)	1.600 (40.64)	2.058 (52.27)										
19	38		71973-9719	71973-9819	71973-9919	1.800 (45.72)	1.895 (48.13)	1.700 (43.18)	2.158 (54.81)										
20	40		71973-9720	71973-9820	71973-9920	1.900 (48.26)	1.995 (50.67)	1.800 (45.72)	2.258 (57.35)										
21	42		71973-9721	71973-9821	71973-9921	2.000 (50.80)	2.095 (53.21)	1.900 (48.26)	2.358 (59.89)										
22	44		71973-9722	71973-9822	71973-9922	2.100 (53.34)	2.195 (55.75)	2.000 (50.80)	2.458 (62.43)										
23	46		71973-9723	71973-9823	71973-9923	2.200 (55.88)	2.295 (58.29)	2.100 (53.34)	2.558 (64.97)										
24	48		71973-9724	71973-9824	71973-9924	2.300 (58.42)	2.395 (60.83)	2.200 (55.88)	2.658 (67.51)										
25	50		71973-9725	71973-9825	71973-9925	2.400 (60.96)	2.495 (63.37)	2.300 (58.42)	2.758 (70.05)										
26	52		71973-9726	71973-9826	71973-9926	2.500 (63.50)	2.595 (65.91)	2.400 (60.96)	2.858 (72.59)										
27	54		71973-9727	71973-9827	71973-9927	2.600 (66.04)	2.695 (68.45)	2.500 (63.50)	2.958 (75.13)										
28	56		71973-9728	71973-9828	71973-9928	2.700 (68.58)	2.795 (70.99)	2.600 (66.04)	3.058 (77.67)										
29	58		71973-9729	71973-9829	71973-9929	2.800 (71.12)	2.895 (73.53)	2.700 (68.58)	3.158 (80.21)										
30	60		71973-9730	71973-9830	71973-9930	2.900 (73.66)	2.995 (76.07)	2.800 (71.12)	3.258 (82.75)										
31	62		71973-9731	71973-9831	71973-9931	3.000 (76.20)	3.095 (78.61)	2.900 (73.66)	3.358 (85.29)										
32	64		71973-9732	71973-9832	71973-9932	3.100 (78.74)	3.195 (81.15)	3.000 (76.20)	3.458 (87.83)										
33	66		71973-9733	71973-9833	71973-9933	3.200 (81.28)	3.295 (83.69)	3.100 (78.74)	3.558 (90.37)										

ADD OPTION K & L EC NO: S2010-0534 DRWN:SKANG CHYD:ATSEE APPR:MLONG 2009/12/30 2010/01/08 2010/01/14	QUALITY SYMBOLS	GENERAL TOLERANCES (UNLESS SPECIFIED)	DIMENSION STYLE	SCALE	DESIGN UNITS	THIRD ANGLE PROJECTION	
	$F_A = 0$ $F_B = 0$ $F_P = 0$	mm    INCH 4 PLACES ± --- ± --- 3 PLACES ± --- ± .010 2 PLACES ± 0.25 ± --- 1 PLACE ± --- ± --- ANGULAR ± 1/2°	IN/MM DRAWN BY DATE DJB 1991/10/21 CHECKED BY DATE DJB 1991/10/21 APPROVED BY DATE MLONG 2010/01/14	NTS TITLE EARLY ENTRY R/A RECPT .120"PC TAIL W/O LOWER ROW PINSTOP-.100" GRID	INCH MOLEX INCORPORATED		SHEET NO. 24 OF 26
	DRAFT WHERE APPLICABLE MUST REMAIN WITHIN DIMENSIONS	SEE TABLE	MATERIAL NO. SDA-71973-****	DOCUMENT NO.	INCORPORATED AND SHOULD NOT BE USED WITHOUT WRITTEN PERMISSION		



NO. OF CKTS		OPTION K ASSEMBLY PACKAGED IN TUBES PER PK-70873-0138 (SEE SHEET I FOR FINISH SPECIFICATIONS)					DIMENSION				NO. OF CKTS		OPTION K ASSEMBLY PACKAGED IN TUBES PER PK-70873-0138 (SEE SHEET I FOR FINISH SPECIFICATIONS)					DIMENSION					
PER ROW	TOTAL	15 GOLD			30 GOLD	50 GOLD	A	B				PER ROW	TOTAL	15 GOLD			30 GOLD	50 GOLD	A	B			
4	8			71973-6204	71973-6304	71973-6404	.300 (7.62)	.395 (10.03)			32	64						3.100 (78.74)	3.195 (81.15)				
5	10			71973-6205	71973-6305	71973-6405	.400 (10.16)	.495 (12.57)			33	66			71973-6232	71973-6332	71973-6432	3.200 (81.28)	3.295 (83.69)				
6	12			71973-6206	71973-6306	71973-6406	.500 (12.70)	.595 (15.11)			34	68			71973-6233	71973-6333	71973-6433	3.300 (83.82)	3.395 (86.23)				
7	14			71973-6207	71973-6307	71973-6407	.600 (15.24)	.695 (17.65)			35	70			71973-6234	71973-6334	71973-6434	3.400 (86.36)	3.495 (88.77)				
8	16			71973-6208	71973-6308	71973-6408	.700 (17.78)	.795 (20.19)			36	72			71973-6235	71973-6335	71973-6435	3.500 (88.90)	3.595 (91.31)				
9	18			71973-6209	71973-6309	71973-6409	.800 (20.32)	.895 (22.73)															
10	20			71973-6210	71973-6310	71973-6410	.900 (22.86)	.995 (25.27)															
11	22			71973-6211	71973-6311	71973-6411	1.000 (25.40)	1.095 (27.81)															
12	24			71973-6212	71973-6312	71973-6412	1.100 (27.94)	1.195 (30.35)															
13	26			71973-6213	71973-6313	71973-6413	1.200 (30.48)	1.295 (32.89)															
14	28			71973-6214	71973-6314	71973-6414	1.300 (33.02)	1.395 (35.43)															
15	30			71973-6215	71973-6315	71973-6415	1.400 (35.56)	1.495 (37.97)															
16	32			71973-6216	71973-6316	71973-6416	1.500 (38.10)	1.595 (40.51)															
17	34			71973-6217	71973-6317	71973-6417	1.600 (40.64)	1.695 (43.05)															
18	36			71973-6218	71973-6318	71973-6418	1.700 (43.18)	1.795 (45.59)															
19	38			71973-6219	71973-6319	71973-6419	1.800 (45.72)	1.895 (48.13)															
20	40			71973-6220	71973-6320	71973-6420	1.900 (48.26)	1.995 (50.67)															
21	42			71973-6221	71973-6321	71973-6421	2.000 (50.80)	2.095 (53.21)															
22	44			71973-6222	71973-6322	71973-6422	2.100 (53.34)	2.195 (55.75)															
23	46			71973-6223	71973-6323	71973-6423	2.200 (55.88)	2.295 (58.29)															
24	48			71973-6224	71973-6324	71973-6424	2.300 (58.42)	2.395 (60.83)															
25	50			71973-6225	71973-6325	71973-6425	2.400 (60.96)	2.495 (63.37)															
26	52			71973-6226	71973-6326	71973-6426	2.500 (63.50)	2.595 (65.91)															
27	54			71973-6227	71973-6327	71973-6427	2.600 (66.04)	2.695 (68.45)															
28	56			71973-6228	71973-6328	71973-6428	2.700 (68.58)	2.795 (70.99)															
29	58			71973-6229	71973-6329	71973-6429	2.800 (71.12)	2.895 (73.53)															
30	60			71973-6230	71973-6330	71973-6430	2.900 (73.66)	2.995 (76.07)															
31	62			71973-6231	71973-6331	71973-6431	3.000 (76.20)	3.095 (78.61)															

\*X\* INDICATES TOOLING IS NOT AVAILABLE

ADD OPTION K & L	QUALITY SYMBOLS
EC NO: S2010-0534	$F_A=0$
DRWN:SKANG	$F_B=0$
CHKD:ATSEE	$F_C=0$
APPR:MLONG	$F_D=0$
2009/12/30	
2010/01/08	
2010/01/14	
DESCRIPTION	
REV	

GENERAL TOLERANCES (UNLESS SPECIFIED)	DIMENSION STYLE	SCALE	DESIGN UNITS	THIRD ANGLE PROJECTION
	IN/MM	NTS	INCH	
4 PLACES	mm INCH	DRAWN BY	DATE	TITLE
3 PLACES	± --- ± ---	DJB	1991/10/21	EARLY ENTRY R/A RECPT
2 PLACES	± --- ± .010	CHECKED BY	DATE	.120"PC TAIL W/O LOWER
1 PLACE	± 0.25 ± ---	DJB	1991/10/21	ROW PINSTOP-.100" GRID
	ANGULAR ± 1/2°	APPROVED BY	DATE	MOLEX INCORPORATED
		MLONG	2010/01/14	
DRAFT WHERE APPLICABLE MUST REMAIN WITHIN DIMENSIONS	SEE TABLE	MATERIAL NO.	DOCUMENT NO.	SHEET NO.
	SIZE A3		SDA-71973-****	25 OF 26

THIS DRAWING CONTAINS INFORMATION THAT IS PROPRIETARY TO MOLEX INCORPORATED AND SHOULD NOT BE USED WITHOUT WRITTEN PERMISSION	
---	--

NO. OF CKTS		OPTION L ASSEMBLY PACKAGED IN TUBES PER PK-70873-0138 (SEE SHEET 1 FOR FINISH SPECIFICATIONS)					DIMENSION			NO. OF CKTS		OPTION L ASSEMBLY PACKAGED IN TUBES PER PK-70873-0138 (SEE SHEET 1 FOR FINISH SPECIFICATIONS)					DIMENSION		
PER ROW	TOTAL	15 GOLD			30 GOLD	50 GOLD	A	B		PER ROW	TOTAL	15 GOLD			30 GOLD	50 GOLD	A	B	
4	8			71973-5404	71973-5504	71973-5604	.300 (7.62)	.395 (10.03)		31	62			71973-5431	71973-5531	71973-5631	3.000 (76.20)	3.095 (78.61)	
5	10			71973-5405	71973-5505	71973-5605	.400 (10.16)	.495 (12.57)		32	64			71973-5432	71973-5532	71973-5632	3.100 (78.74)	3.195 (81.15)	
6	12			71973-5406	71973-5506	71973-5606	.500 (12.70)	.595 (15.11)		33	66			71973-5433	71973-5533	71973-5633	3.200 (81.28)	3.295 (83.69)	
7	14			71973-5407	71973-5507	71973-5607	.600 (15.24)	.695 (17.65)		34	68			71973-5434	71973-5534	71973-5634	3.300 (83.82)	3.395 (86.23)	
8	16			71973-5408	71973-5508	71973-5608	.700 (17.78)	.795 (20.19)		35	70			71973-5435	71973-5535	71973-5635	3.400 (86.36)	3.495 (88.77)	
9	18			71973-5409	71973-5509	71973-5609	.800 (20.32)	.895 (22.73)		36	72			71973-5436	71973-5536	71973-5636	3.500 (88.90)	3.595 (91.31)	
10	20			71973-5410	71973-5510	71973-5610	.900 (22.86)	.995 (25.27)											
11	22			71973-5411	71973-5511	71973-5611	1.000 (25.40)	1.095 (27.81)											
12	24			71973-5412	71973-5512	71973-5612	1.100 (27.94)	1.195 (30.35)											
13	26			71973-5413	71973-5513	71973-5613	1.200 (30.48)	1.295 (32.89)											
14	28			71973-5414	71973-5514	71973-5614	1.300 (33.02)	1.395 (35.43)											
15	30			71973-5415	71973-5515	71973-5615	1.400 (35.56)	1.495 (37.97)											
16	32			71973-5416	71973-5516	71973-5616	1.500 (38.10)	1.595 (40.51)											
17	34			71973-5417	71973-5517	71973-5617	1.600 (40.64)	1.695 (43.05)											
18	36			71973-5418	71973-5518	71973-5618	1.700 (43.18)	1.795 (45.59)											
19	38			71973-5419	71973-5519	71973-5619	1.800 (45.72)	1.895 (48.13)											
20	40			71973-5420	71973-5520	71973-5620	1.900 (48.26)	1.995 (50.67)											
21	42			71973-5421	71973-5521	71973-5621	2.000 (50.80)	2.095 (53.21)											
22	44			71973-5422	71973-5522	71973-5622	2.100 (53.34)	2.195 (55.75)											
23	46			71973-5423	71973-5523	71973-5623	2.200 (55.88)	2.295 (58.29)											
24	48			71973-5424	71973-5524	71973-5624	2.300 (58.42)	2.395 (60.83)											
25	50			71973-5425	71973-5525	71973-5625	2.400 (60.96)	2.495 (63.37)											
26	52			71973-5426	71973-5526	71973-5626	2.500 (63.50)	2.595 (65.91)											
27	54			71973-5427	71973-5527	71973-5627	2.600 (66.04)	2.695 (68.45)											
28	56			71973-5428	71973-5528	71973-5628	2.700 (68.58)	2.795 (70.99)											
29	58			71973-5429	71973-5529	71973-5629	2.800 (71.12)	2.895 (73.53)											
30	60			71973-5430	71973-5530	71973-5630	2.900 (73.66)	2.995 (76.07)											

"X" INDICATES TOOLING IS NOT AVAILABLE  ADD OPTION K & L EC NO: S2010-0534 DRWN:SKANG 2009/12/30 CHYD:ATSEE 2010/01/08 APPR:MLONG 2010/01/14 K	QUALITY SYMBOLS	GENERAL TOLERANCES (UNLESS SPECIFIED)	DIMENSION STYLE	SCALE	DESIGN UNITS	THIRD ANGLE PROJECTION	
	$F_A = 0$ $F_C = 0$ $F_P = 0$	mm      INCH 4 PLACES ± --- ± --- 3 PLACES ± --- ± .010 2 PLACES ± 0.25 ± --- 1 PLACE ± --- ± --- ANGULAR ± 1/2°	IN/MM DRAWN BY DATE DJB 1991/10/21 CHECKED BY DATE DJB 1991/10/21 APPROVED BY DATE MLONG 2010/01/14	NTS TITLE EARLY ENTRY R/A RECPT .120"PC TAIL W/O LOWER ROW PINSTOP-.100" GRID	INCH MOLEX INCORPORATED		SEE TABLE SDA-71973-****
	DRAFT WHERE APPLICABLE MUST REMAIN WITHIN DIMENSIONS	MATERIAL NO.	DOCUMENT NO.	SHEET NO.			
	SIZE A3	THIS DRAWING CONTAINS INFORMATION THAT IS PROPRIETARY TO MOLEX INCORPORATED AND SHOULD NOT BE USED WITHOUT WRITTEN PERMISSION					