

FEATURES

Personal System/2* and VGA* Compatible
Plug-in Replacement for INMOS 171/176
66 MHz Pipelined Operation
Three 6-Bit D/A Converters
256 × 18 Color Palette RAM
RS-343A/RS-170 Compatible Outputs
Blank on All Three Channels
Standard MPU Interface
Asynchronous Access to All Internal Registers
+5 V CMOS Monolithic Construction
Low Power Dissipation
Standard 28-Pin, 0.6" DIP and 44-Pin PLCC

APPLICATIONS

High Resolution Color Graphics
CAE/CAD/CAM Applications
Image Processing
Instrumentation
Desktop Publishing

AVAILABLE CLOCK RATES

66 MHz
50 MHz
35 MHz

GENERAL DESCRIPTION

The ADV476 (ADV[®]) is a pin compatible and software compatible RAM-DAC designed specifically for VGA and Personal System/2 color graphics.

The ADV476 is a complete analog output RAM-DAC on a single monolithic chip. The part contains a 256 × 18 color lookup table, a pixel mask register as well as a triple 6-bit video D/A converter. The ADV476 is capable of simultaneously displaying up to 256 colors, from a total color palette of 262,144 addressable colors.

The on-chip asynchronous MPU bus allows access to the color lookup table without affecting the input video data via the pixel port. The pixel read mask register provides a convenient way of altering the displayed colors without updating the color lookup table. The ADV476 is capable of generating RGB video output signals which are compatible with RS-343A and RS-170 video standards, without requiring external buffering.

*Personal System/2 and VGA are trademarks of International Business Machines Corp.
 ADV is a registered trademark of Analog Devices, Inc.

REV. B

Information furnished by Analog Devices is believed to be accurate and reliable. However, no responsibility is assumed by Analog Devices for its use, nor for any infringements of patents or other rights of third parties which may result from its use. No license is granted by implication or otherwise under any patent or patent rights of Analog Devices.

FUNCTIONAL BLOCK DIAGRAM

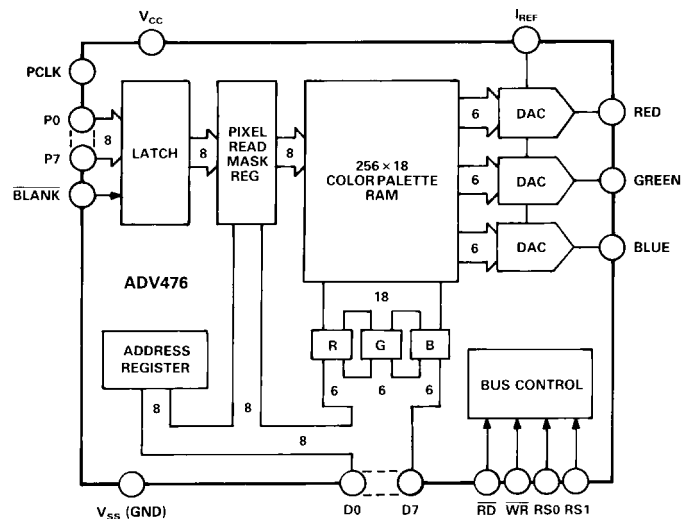

The ADV476 is fabricated in a +5 V CMOS process. Its monolithic CMOS construction ensures greater functionality with low power dissipation and small board area. The part is packaged in a 0.6", 28-pin DIP and a 44-pin PLCC.

PRODUCT HIGHLIGHTS

1. Standard video refresh rates, 35 MHz, 50 MHz and 66 MHz.
2. Fully compatible with VGA and Personal System/2 color graphics.
3. Guaranteed monotonic. Integral and differential linearity guaranteed to be a maximum of ±1 LSB.
4. Low glitch energy, 75 pV secs.

ADV476—SPECIFICATIONS

($V_{CC} = +5\text{ V} \pm 10\%$, $I_{REF} = 8.88\text{ mA}$)

All Specifications T_{MIN} to T_{MAX} ¹ unless otherwise noted.)

Parameter	All Versions	Units	Test Conditions/Comments
STATIC PERFORMANCE			
Resolution (Each DAC)	6	Bits	Guaranteed Monotonic Full Scale = $2.15 \times I_{REF} \times R_L$, $I_{REF} = 8.39\text{ mA}$ $\overline{\text{BLANK}}$ = Logic Low $\overline{\text{BLANK}}$ = Logic High
Accuracy (Each DAC)			
Integral Nonlinearity	± 0.5	LSB max	
Full Scale Error	± 5	% max	
Blank Level	± 0.5	LSB max	
Offset Error	± 0.5	LSB max	
DIGITAL INPUTS			
Input High Voltage, V_{INH}	2	V min	$V_{CC} = 5.5\text{ V}$, $V_{IN} = 0.4\text{ V}$ to V_{CC} $V_{CC} = 5.5\text{ V}$, $V_{IN} = 0.4\text{ V}$ to V_{CC}
Input Low Voltage, V_{INL}	0.8	V max	
Input Current, I_{IN}	± 10	μA max	
Input Current ($\overline{\text{RD}}$ Input Only)	± 100	μA max	
Input Capacitance, C_{IN}	7	pF typ	
DIGITAL OUTPUTS			
Output High Voltage, V_{OH}	2.4	V min	$I_{SOURCE} = 500\ \mu\text{A}$, $V_{CC} = 4.5\text{ V}$ $I_{SINK} = 5.0\text{ mA}$, $V_{CC} = 4.5\text{ V}$ $V_{CC} = 5.5\text{ V}$, $0.4\text{ V} < V_{IN} < V_{CC}$
Output Low Voltage, V_{OL}	0.4	V max	
Floating-State Leakage Current	± 50	μA max	
Floating-State Output Capacitance	7	pF typ	
ANALOG OUTPUTS			
Max Output Voltage	1.5	V min	$I_O < 10\text{ mA}$, $I_O = 2.15 \times I_{REF}$ $V_O \leq 1\text{ V}$ $\overline{\text{BLANK}}$ = Logic Low
Max Output Current	21	mA min	
DAC to DAC Matching ²	± 2.5	% max	
Analog Output Capacitance	10	pF typ	
CURRENT REFERENCE			
Input Current (I_{REF}) Range	$-3/-10$	mA min/mA max	$I_{REF} = 8.88\text{ mA}$
Voltage at I_{REF}	$V_{CC} - 3/V_{CC}$	V min/V max	
POWER SUPPLY			
Supply Voltage, V_{CC}	4.5/5.5	V min/V max	$f_{MAX} = 66\text{ MHz}$ $I_O = 2.15 \times I_{REF}$, D0–D7 Unloaded $4.5 < V_{CC} < 5.5\text{ V}$, $I_O = 2.15 \times I_{REF}$, $R_L = 37.5\ \Omega$, $C_L = 30\text{ pF}$, $I_{REF} = 8.88\text{ mA}$.
Supply Current, I_{CC}	220	mA max	
Power Supply Rejection Ratio	6	%/V	
DYNAMIC PERFORMANCE			
Clock and Data Feedthrough ^{3, 4}	-35	dB typ	
Glitch Impulse ^{3, 4}	75	pV secs typ	

NOTES

¹Temperature range (T_{MIN} to T_{MAX}); 0 to $+70^\circ\text{C}$.

²Relative to the midpoint of the distribution of the three DACs measured at full scale.

³TTL input values are 0 to 3 volts, with input rise/fall times $\leq 3\text{ ns}$, measured between the 10% and 90% points. Timing reference points at 50% for inputs and outputs. Analog output load $\leq 10\text{ pF}$, $37.5\ \Omega$. D0–D7 output load $\leq 50\text{ pF}$. See timing notes in Figure 2.

⁴Clock and data feedthrough is a function of the amount of overshoot and undershoot on the digital inputs. For this test, the digital inputs have a $1\text{ k}\Omega$ resistor to ground and are driven by 74HC logic. Glitch impulse includes clock and data feedthrough, -3 dB test bandwidth = $2 \times$ clock rate.

Specifications subject to change without notice.

TIMING CHARACTERISTICS¹ ($V_{CC} = +5\text{ V} \pm 10\%$. All Specifications T_{MIN} to T_{MAX} ²)

Parameter	66 MHz Version	50 MHz Version	35 MHz Version	Units	Conditions/Comments
f_{MAX}	66	50	35	MHz	Clock Rate
t_1	10	10	15	ns min	RS0, RS1 Setup Time
t_2	10	10	15	ns min	RS0, RS1 Hold Time
t_3	5	5	5	ns min	\overline{RD} Asserted to Data Bus Driven
t_4	40	40	40	ns max	\overline{RD} Asserted to Data Valid
t_5	20	20	20	ns max	\overline{RD} Negated to Data Bus 3-States
t_6	10	10	15	ns min	Write Data Setup Time
t_7	10	10	15	ns min	Write Data Hold Time
t_8	50	50	50	ns min	\overline{RD} , \overline{WR} Pulse Width Low
t_9	$4 \times t_{12}$	$4 \times t_{12}$	$4 \times t_{12}$	ns min	\overline{RD} , \overline{WR} Pulse Width High
t_{10}	3	3	4	ns min	Pixel & Control Setup Time
t_{11}	3	3	4	ns min	Pixel & Control Hold Time
t_{12}	15.3	20	28	ns min	Clock Cycle Time
t_{13}	5	6	7	ns min	Clock Pulse Width High Time
t_{14}	5	6	9	ns min	Clock Pulse Width Low Time
t_{15}	30	30	30	ns max	Analog Output Delay
	5	5	5	ns min	
t_{16}	6	8	8	ns max	Analog Output Rise/Fall Time
t_{17} ³	15.3	20	25	ns typ	Analog Output Settling Time
t_{18}	2	2	2	ns min	Analog Output Skew
t_{PD}	4	4	4	clocks	Pipeline Delay

NOTES

¹TTL input values are 0 to 3 volts, with input rise/fall times ≤ 3 ns, measured between the 10% and 90% points. Timing reference points at 50% for inputs and outputs. Analog output load ≤ 10 pF, 37.5 Ω . D0–D7 output load ≤ 50 pF. See timing notes in Figure 2.

²Temperature Range (T_{MIN} to T_{MAX}); 0 to +70°C

³Settling time does not include clock and data feedthrough. For this test, the digital inputs have a 1 k Ω resistor to ground and are driven by 74HC logic.

Specifications subject to change without notice.

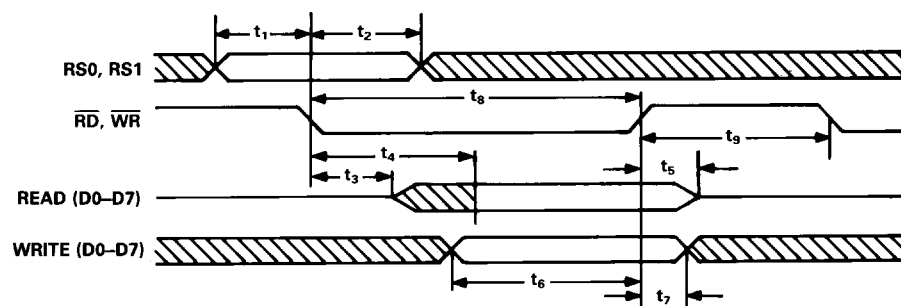
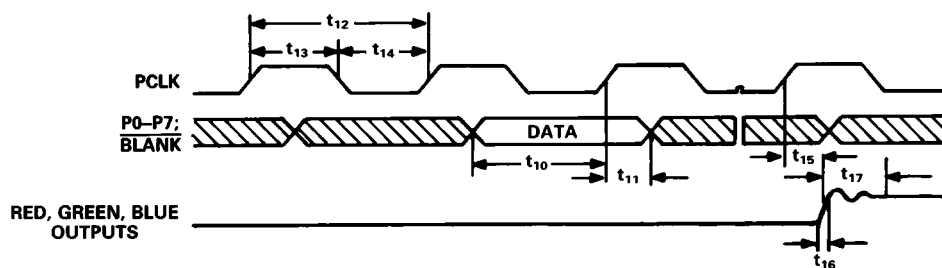

Figure 1. MPU Read/Write Timing



NOTES

1. OUTPUT DELAY (t_{15}) MEASURED FROM THE 50% POINT OF THE RISING EDGE OF THE PCLK TO THE 50% POINT OF FULL SCALE TRANSITION.
2. SETTling TIME (t_{17}) MEASURED FROM THE 50% POINT OF FULL SCALE TRANSITION TO THE OUTPUT REMAINING WITHIN $\pm 1/4$ LSB.
3. OUTPUT RISE/FALL TIME (t_{16}) MEASURED BETWEEN THE 10% AND 90% POINTS OF FULL SCALE TRANSITION.

Figure 2. Video Input/Output Timing

ADV476

ABSOLUTE MAXIMUM RATINGS¹

V _{CC} to GND	+7 V
Voltage on any Digital Pin	GND - 0.5 V to V _{CC} + 0.5 V
Ambient Operating Temperature (T _A)	-55°C to +125°C
Storage Temperature (T _S)	-65°C to +150°C
Junction Temperature (T _J)	+150°C
Lead Temperature (Soldering, 10 secs)	+300°C
Vapor Phase Soldering (1 minute)	+220°C
Red, Green, Blue to GND ²	0 V to V _{CC}

NOTES

¹Stresses above those listed under "Absolute Maximum Ratings" may cause permanent damage to the device. This is a stress rating only and functional operation of the device at these or any other conditions above those listed in the operational sections of this specification is not implied. Exposure to absolute maximum rating conditions for extended periods may affect device reliability.

²Analog output short circuit to any power supply or common can be of an indefinite duration.

ORDERING GUIDE^{1,2}

Model	Speed	Package Type	Package Option ³
ADV476KN35	35 MHz	28-Pin DIP	N-28
ADV476KN50	50 MHz	28-Pin DIP	N-28
ADV476KN66	66 MHz	28-Pin DIP	N-28
ADV476KP35	35 MHz	44-Pin PLCC	P-44A
ADV476KP50	50 MHz	44-Pin PLCC	P-44A
ADV476KP66	66 MHz	44-Pin PLCC	P-44A

NOTES

¹All devices are specified for 0°C to +70°C operation.

²Devices are packaged in 0.6" 28-pin plastic DIPs (N-28), and 44-pin J-leaded PLCC (P-44A).

³N = Plastic DIP; P = Plastic Leaded Chip Carrier.

RECOMMENDED OPERATING CONDITIONS

Parameter	Symbol	Min	Typ	Max	Units
Power Supply	V _{CC}	4.5	5.00	5.5	Volts
Ambient Operating Temperature	T _A	0		+70	°C
Output Load	R _L		37.5		Ω
Reference Current	I _{REF}	-3		-10	mA

CAUTION

ESD (electrostatic discharge) sensitive device. Electrostatic charges as high as 4000 V readily accumulate on the human body and test equipment and can discharge without detection. Although the ADV476 features proprietary ESD protection circuitry, permanent damage may occur on devices subjected to high energy electrostatic discharges. Therefore, proper ESD precautions are recommended to avoid performance degradation or loss of functionality.



PIN CONFIGURATIONS

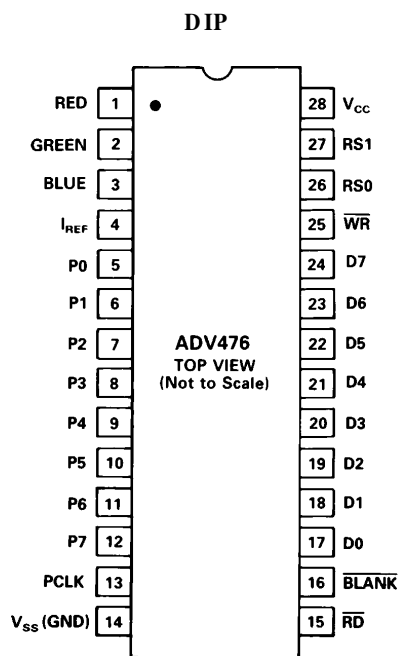
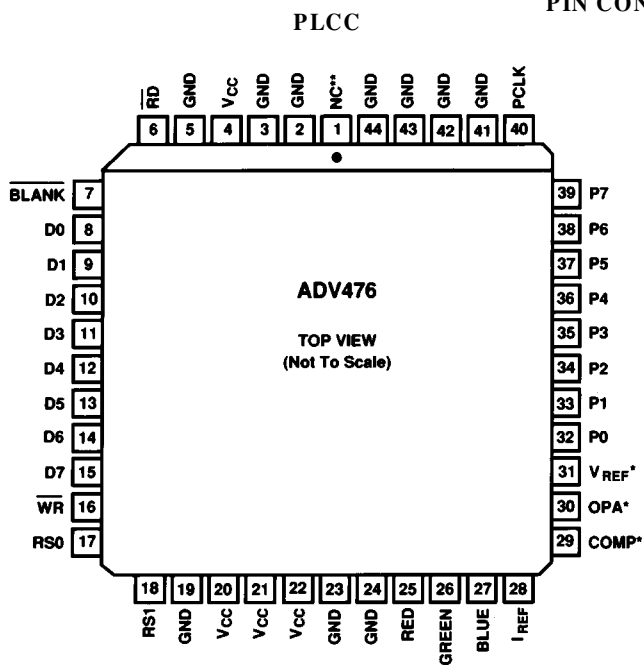

*V_{REF} MUST BE TERMINATED THROUGH A 0.1μF CERAMIC CAPACITOR TO V_{CC}. OPA IS LEFT UNCONNECTED; COMP IS CONNECTED TO I_{REF} (SEE FIGURE 8).
**NC = NO CONNECT

The above pins allow the ADV476KP (44-Pin PLCC) to be alternatively driven by a voltage reference. If it is desired to use a voltage reference configuration instead of the current reference configuration described in this data sheet, the above listed pins must be connected as described in Figure 6 of the ADV478/ADV471 data sheet of this reference manual.

PIN FUNCTION DESCRIPTION

Pin Mnemonic	Function
$\overline{\text{BLANK}}$	Composite blank control input (TTL compatible). A logic zero on this control input drives the analog outputs to the blanking level, as shown in Table V. The $\overline{\text{BLANK}}$ signal is latched on the rising edge of PCLK. While $\overline{\text{BLANK}}$ is a logical zero, the pixel inputs are ignored.
PCLK	Clock input (TTL compatible). The rising edge of PCLK latches the P0–P7 data inputs and the $\overline{\text{BLANK}}$ control input. It is typically the pixel clock rate of the video system. PCLK should be driven by a dedicated TTL buffer.
P0–P7	Pixel select inputs (TTL compatible). These inputs specify, on a pixel basis, which one of the 256 entries in the color palette RAM is to be used to provide color information. P0–P7 pixel select inputs are latched on the rising edge of PCLK. P0 is the LSB. Unused pixel select inputs should be connected to GND.
RED, GREEN, BLUE	Red, green and blue current outputs. These high impedance current sources are capable of directly driving a doubly terminated 75 Ω coaxial cable, as shown in Figure 4a. All three current outputs should have similar output loads whether or not they are all being used.
V _{CC}	Analog power supply (5 V \pm 10%).
GND	Analog ground.
I _{REF}	Current reference input. The relationship between the current input and the full scale output voltage of the DACs is given by the following expression: $I_{\text{REF}} = \text{VO (Full Scale)} / 2.15 \times R_L$ $R_L = \text{Load Resistance}$
$\overline{\text{WR}}$	Write control input (TTL compatible). $\overline{\text{WR}}$ must be at logical zero when writing data to the device. D0–D7 data is latched on the rising edge of $\overline{\text{WR}}$. See Figure 1.
$\overline{\text{RD}}$	Read control input (TTL compatible). $\overline{\text{RD}}$ must both be at logical zero when reading data from the device. See Figure 1.
RS0, RS1	Command control inputs (TTL compatible). RS0 and RS1 specify the type of read or write operation being carried out, i.e., address register or color palette RAM read or write operations. See Tables I, II, III.
D0–D7	Data bus (TTL compatible). Data is transferred to and from the address register and the color palette RAM over this 8-bit bidirectional data bus. D0 is the least significant bit.

TERMINOLOGY

Blanking Level

The level separating the SYNC portion from the Video portion of the waveform. Usually referred to as the Front Porch or Back Porch. At 0 IRE Units, it is the level which will shut off the picture tube, resulting in the blackest possible picture.

Color Video (RGB)

This usually refers to the technique of combining the three primary colors of Red, Green and Blue to produce color pictures within the usual spectrum. In RGB monitors, three DACs are required, one for each color.

Gray Scale

The discrete levels of video signal between Reference Black and Reference White levels. An 8-bit DAC contains 256 different levels while a 6-bit DAC contains 64.

Raster Scan

The most basic method of sweeping a CRT one line at a time to generate and display images.

Reference Black Level

The maximum negative polarity amplitude of the video signal.

Reference White Level

The maximum positive polarity amplitude of the video signal.

Video Signal

That portion of the composite video signal which varies in gray scale levels between Reference White and Reference Black. Also referred to as the picture signal, this is the portion which may be visually observed.

ADV476

MPU Interface

As illustrated in the functional block diagram, the ADV476 supports a standard MPU bus interface, allowing the MPU direct access to the color palette RAM.

The RS0 and RS1 control inputs specify whether the MPU is accessing the address register or the color palette RAM, as shown in Table I. The 8-bit address register is used to address the color palette RAM, eliminating the requirement for external address multiplexers.

Table I. Control Input Truth Table

RS1	RS0	Addressed by MPU
0	0	Pixel Address Register (RAM Write Mode)
1	1	Pixel Address Register (RAM Read Mode)
0	1	Color Palette RAM
1	0	Pixel Read Mask Register

To write color data, the MPU writes to the address register with the 8-bit address of the color palette RAM location which is to be modified. The MPU performs three successive write cycles (six bits of red data, six bits of green data and six bits of blue data). During the blue write cycle, the three bytes of color information are concatenated into an 18-bit word and written to the location specified by the address register. The address register then automatically increments to the next location which the MPU may modify by simply writing another sequence of red, green and blue data.

To read back color data, the MPU loads the address register with the address of the color palette RAM location to be read. The MPU performs three successive read cycles (6 bits each of red, green and blue data). Following the blue read cycle, the

address register increments to the next location which the MPU may read by simply reading another sequence of red, green and blue data.

This 6-bit color data is right justified, i.e., the lower six bits of the data bus with D0 being the LSB and D5 the MSB. D6 and D7 are ignored during a color write cycle and are set to zero during a color read cycle.

During color palette RAM access, the address register resets to 00H following a blue read or write operation to RAM location FFH.

The MPU interface operates asynchronously to the pixel clock. Data transfers between the color palette RAM and the color registers (R, G, and B in the block diagram) are synchronized by internal logic, and occur in the period between MPU accesses. Color (RGB) data is normally loaded to the color palette RAM during video screen retrace, i.e., during the video waveform blanking period, see Figure 5.

To keep track of the red, green and blue read/write cycles, the address register has two additional bits (ADDRa, ADDRb) that count modulo three, as shown in Table II. They are reset to zero when the MPU writes to the address register, and are not reset to zero when the MPU reads the address register. The MPU does not have access to these bits. The other eight bits of the address register, incremented following a blue read or write cycle, (ADDR0–7) are accessible to the MPU, and are used to address color palette RAM locations, as shown in Table III. ADDR0 is the LSB when the MPU is accessing the RAM. The MPU may read the address register at any time without modifying its contents or the existing read/write mode.

Figure 1 illustrates the MPU read/write timing and Table III shows the associated functional instructions.

Table II. Address Register (ADDR) Operation

	Value	RS1	RS0	Addressed by MPU
ADDRa,b (Counts Modulo 3)	00			Red Value
	01			Green Value
	10			Blue Value
ADDR0–7 (Counts Binary)	00H–FFH	0	1	Color Palette RAM

Table III. Truth Table for Read/Write Operations

\overline{RD}	\overline{WR}	RS0	RS1	ADDRa	ADDRb	Operation Performed
1	0	0	0	X	X	Write Address Register; D0–D7→ADDR0–7 0→ADDRa,b
1	0	1	0	0	0	Write Red Value; Increment ADDRa–b
1	0	1	0	0	1	Write Green Value; Increment ADDRa–b
1	0	1	0	1	0	Write Blue Value; Modify RAM Location Increment ADDR0–7 Increment ADDRa–b
0	1	1	1	X	X	Read Address Register; ADDR0–7→D0–D7
0	1	1	0	0	0	Read Red Value; Increment ADDRa–b
0	1	1	0	0	1	Read Green Value; Increment ADDRa–b
0	1	1	0	1	0	Read Blue Value; Increment ADDR0–7 Increment ADDRa–b
0	0	X	X	X	X	Invalid Operation

Frame Buffer Interface

The P0-P7 inputs are used to address the color palette RAM, as shown in Table IV. These inputs are latched on the rising edge of PCLK and address any of the 256 locations in the color palette RAM. The addressed location contains 18 bits of color (6 bits of red, 6 bits of green and 6 bits of blue) information. This data is transferred to the three DACs and is then converted to an analog output (RED, GREEN, BLUE), these outputs then control the red, green and blue electron guns in the monitor.

The $\overline{\text{BLANK}}$ input is also latched on the rising edge of PCLK. This is to maintain synchronization with the color data.

Table IV. Pixel Select/Color Palette Control Truth Table

P0-P7	Addressed by Frame Buffer
00H	Color Palette RAM Location 00H
01H	Color Palette RAM Location 01H
•	• •
•	• •
FFH	Color Palette RAM Location FFH

Pixel Read Mask Register

The Pixel Read Mask Register in the ADV476 can be used to implement register level pixel processing, thereby cutting down on software overhead. This is achieved by gating the input pixel stream (P0-P7) with the contents of the pixel read mask register. The operation is a bitwise logical ANDing of the pixel data. The contents of This register can be accessed and altered at any time by the MPU (D0-D7). Table I shows the relevant control signals.

This pixel masking operation can be used to alter the displayed colors without changing the contents of either the video frame

buffer or the color palette RAM. The effect of this operation is to partition the color palette into a user determined number of color planes. This process can be used for special effects including animation, overlays and flashing objects.

(See also application note entitled “Animation Using the Pixel Read Mask Register of the ADV47x Series of Video RAM-DACs,” available from Analog Devices (Pub No. E1316-15-10/89).

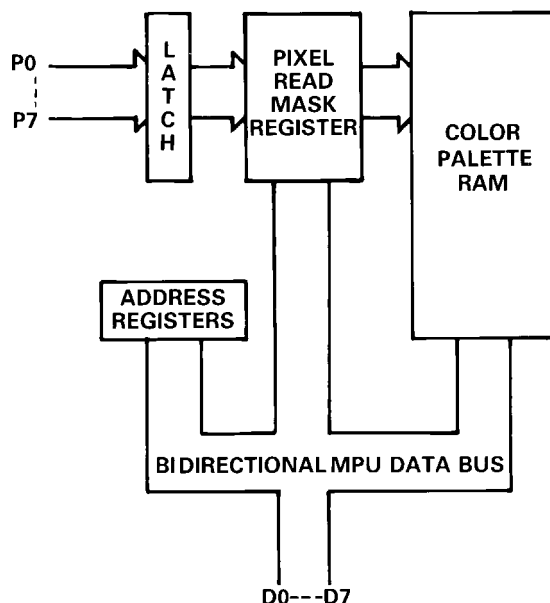

Figure 3. Block Diagram Showing Pixel Read Mask Register

Analog Interface

The ADV476 has three analog outputs, corresponding to the Red, Green and Blue video signals.

The Red, Green and Blue analog outputs of the ADV476 are high impedance current sources. Each one of these three RGB current outputs is capable of directly driving a 37.5 Ω load, such as a doubly-terminated 75 Ω coaxial cable. Figure 4a shows the required configuration for each of the three RGB outputs connected into a doubly-terminated 75 Ω load. This arrangement will develop RS-343A video output voltage levels across a 75 Ω monitor. A simple method of driving RS-170 video levels into a 75 Ω monitor is shown in Figure 4b. The output current levels of the DACs remain unchanged but the source termination

resistance, Z_s on each of the three DACs is increased from 75 Ω to 150 Ω.

More detailed information regarding load terminations for various output configurations, including RS-343A and RS-170, is available in an application note entitled “Video Formats & Required Load Terminations,” available from Analog Devices.

Figure 5 shows the video waveforms associated with the three RGB outputs, driving the doubly terminated 75 Ω load of Figure 4a. The $\overline{\text{BLANK}}$ control input drives the analog outputs to the Black Level. $\overline{\text{BLANK}}$ is asserted prior to horizontal and vertical screen retrace. Table V details how the $\overline{\text{BLANK}}$ input modifies the output levels.

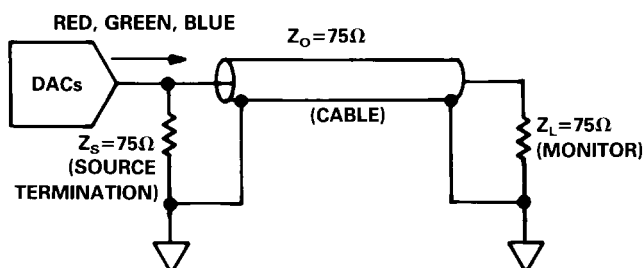

Figure 4a. Recommended Analog Output Termination for RS-343A

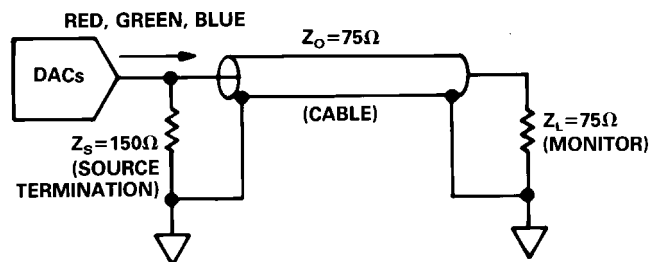
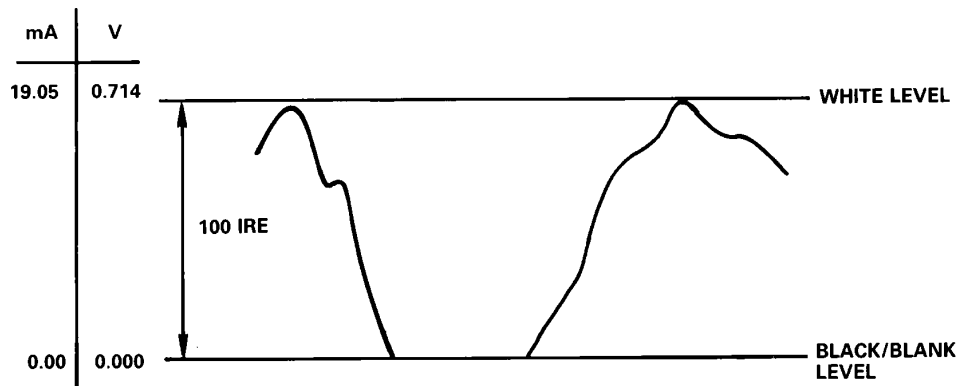

Figure 4b. Recommended Analog Output Termination for RS-170



- NOTES**
1. OUTPUTS CONNECTED TO A DOUBLY TERMINATED 75Ω LOAD.
 2. $I_{REF}=8.88\text{mA}$.
 3. RS-343A LEVELS AND TOLERANCES ASSUMED ON ALL LEVELS.

Figure 5. RGB Video Output Waveform

Table V. Video Output Truth Table

Description	RED, GREEN, BLUE, (mA) ¹	<u>BLANK</u>	DAC Input Data
WHITE LEVEL	19.05	1	FFH
VIDEO	Video	1	DATA
BLACK LEVEL	0	1	00H
BLANK LEVEL	0	0	xxH

NOTE

¹Typical with full Scale RED, GREEN, BLUE = 19.05 mA. I_{REF} = 8.88 mA.

Reference Input

The ADV476 requires an active current reference to enable the DACs provide stable and accurate video output levels. The relationship between the output voltage and the required input reference current is given by:

$$I_{REF} = \frac{VO(FULL\ SCALE)}{2.15 \times R_L}$$

where $R_L = 37.5 \Omega$ (for doubly terminated 75 Ω load)
 $= 75 \Omega$ (for singly terminated 75 Ω load)

and $VO = 0.714 \text{ V}$ (RS-343A video levels)
 $= 1.0 \text{ V}$ (RS-170 video levels).

In a standard application which requires RS-343A video levels to be driven into a doubly terminated 75 Ω load ($R_L = 37.5 \Omega$), the necessary reference input current is:

$$I_{REF} = 8.88 \text{ mA}.$$

To drive the same levels into a singly terminated 75 Ω load ($R_L = 75 \Omega$), the reference current is:

$$I_{REF} = 4.44 \text{ mA}.$$

A suggested current reference design for the doubly terminated case, with RS-343A video levels and based on the LM334, a three-terminal adjustable current source, is shown in Figure 6.

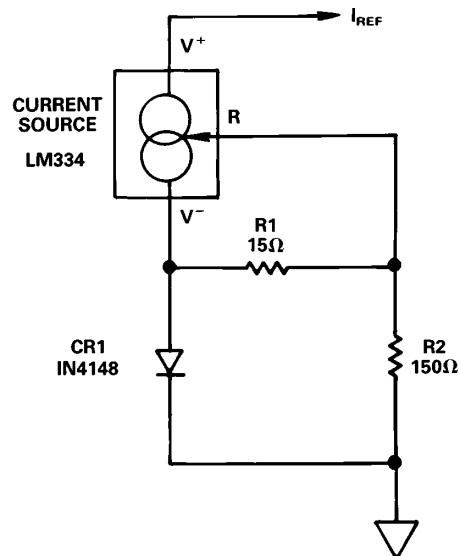

Figure 6. Current Reference Design Using an LM334 Current Source

PC BOARD LAYOUT CONSIDERATIONS

The ADV476 is optimally designed for lowest noise performance, both radiated and conducted noise. For optimum system noise performance, it is imperative that great care be given to the PC board layout. The layout should be optimized for lowest noise on the ADV476 power and ground lines. This can be achieved by shielding the digital inputs and providing good decoupling. The lead length between groups of V_{CC} and GND pins should be minimized so as to minimize inductive ringing.

Ground Planes

The ground plane should encompass all ADV476 ground pins, voltage reference circuitry, power supply bypass circuitry, the analog output traces and all the digital signal traces leading up to the ADV476.

Power Planes

The PC board layout should have two distinct power planes, one for analog circuitry and one for digital circuitry. The analog power plane (V_{CC}) should encompass the ADV476 and all associated analog circuitry. This power plane should be connected to the regular PCB power plane at a single point through a ferrite bead, as illustrated in Figure 7. This bead should be located within three inches of the ADV476.

The PCB power plane should provide power to all digital logic on the PC board, and the analog power plane should provide power to all ADV476 power pins, current reference circuitry and any output amplifiers.

The PCB power and ground planes should not overlay portions of the analog power plane. Keeping the PCB power and ground planes from overlaying the analog power plane will contribute to a reduction in plane-to-plane noise coupling.

Supply Decoupling

Noise on the analog power plane can be further reduced by the use of multiple decoupling capacitors, see Figure 7.

Optimum performance is achieved by the use of 0.1 μF ceramic capacitors. This should be done by placing the capacitors as close as possible to the device with the capacitor leads as short as possible, thus minimizing lead inductance.

It is important to note that while the ADV476 contains circuitry to reject power supply noise, this rejection decreases with frequency. If a high frequency switching power supply is used, the designer should pay close attention to reducing power supply noise. A dc power supply filter (Murata BNX002) will provide EMI suppression between the switching power supply and the main PCB. Alternatively, consideration could be given to using a three terminal voltage regulator.

Digital Signal Interconnect

The digital signal lines to the ADV476 should be isolated as much as possible from the analog outputs and other analog circuitry. Digital signal lines should not overlay the analog power plane.

Due to the high clock rates used, long clock lines to the ADV476 should be avoided so as to minimize noise pickup.

Any active pull-up termination resistors for the digital inputs should be connected to the regular PCB power plane and not the analog power plane.

Analog Signal Interconnect

The ADV476 should be located as close as possible to the output connectors thus minimizing noise pickup and reflections due to impedance mismatch.

The video output signals should overlay the ground plane, and not the analog power plane, thereby maximizing the high frequency power supply rejection.

For optimum performance, the analog outputs should each have a source termination resistance to ground of 75 Ω . This termination resistance should be as close as possible to the ADV476 to minimize reflections.

Note: For additional information on PC Board-Layout see Application Note "Design and Layout of a Video Graphics System for Reduced EMI", available from Analog Devices (Pub. No. E1309-15-10/89).

ADV476

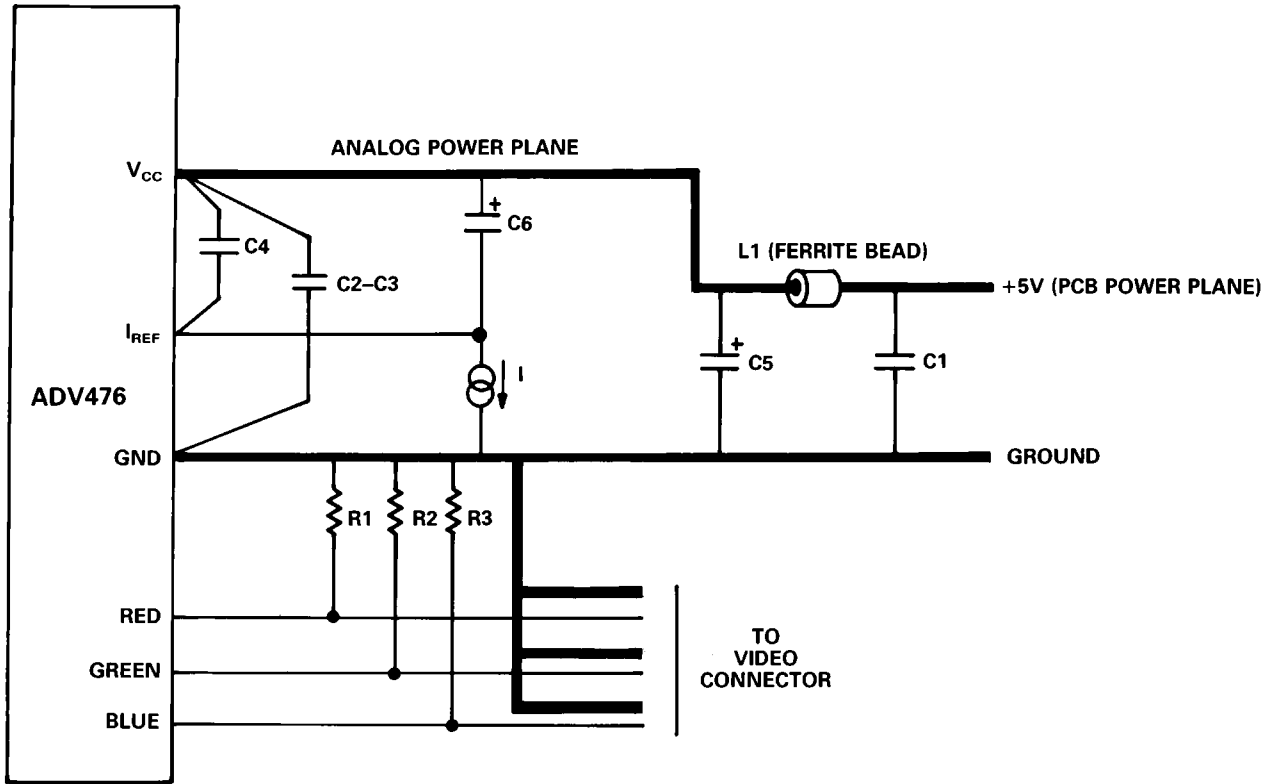

COMPONENT	DESCRIPTION	VENDOR PART NUMBER
C1-C4	0.1 μ F CERAMIC CAPACITOR	ERIE RPE112Z5U104M50V
C5	10 μ F TANTALUM CAPACITOR	MALLORY CSR13G106KM
C6	47 μ F TANTALUM CAPACITOR	MALLORY CSR13F476KM
L1	FERRITE BEAD	FAIR-RITE 2743001111
R1, R2, R3	75 Ω 1% METAL FILM RESISTOR	DALE CMF-55C

Figure 7. ADV476 Typical Connection Diagram and Component List

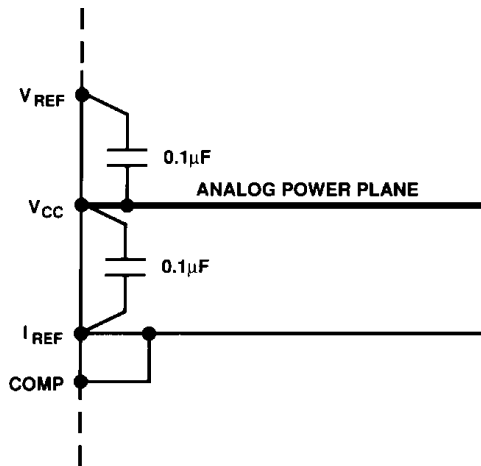
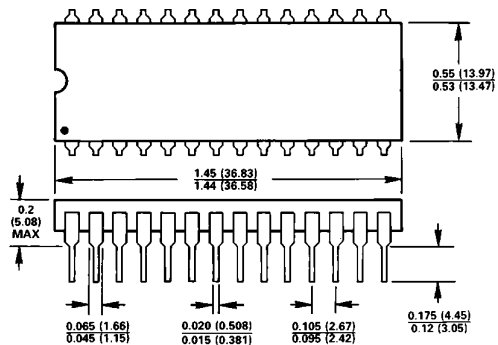

Figure 8. Connection of V_{REF} and COMP with the ADV476KP (44-Pin PLCC)

OUTLINE DIMENSIONS

Dimensions shown in inches and (mm).

28-Pin Plastic DIP (N-28)



LEAD NO. 1 IDENTIFIED BY DOT OR NOTCH
LEADS ARE SOLDER OR TIN PLATED KOVAR OR ALLOY 42

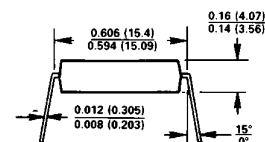

Package/Price Information

CMOS 66 MHz Monolithic 256 x 18 Color Palette RAM-DAC

Model	Status	Package Description	Pin Count	Temperature Range	Price* (100-499)
ADV476KN35	PRODUCTION	PLASTIC/EPOXY DIP	28	COMMERCIAL	\$4.50
ADV476KN50	PRODUCTION	PLASTIC/EPOXY DIP	28	COMMERCIAL	\$5.00
ADV476KN66	PRODUCTION	PLASTIC/EPOXY DIP	28	COMMERCIAL	-
ADV476KN80	PRODUCTION	PLASTIC/EPOXY DIP	28	COMMERCIAL	-
ADV476KP100	PRODUCTION	PLASTIC LEAD CHIP CARRIER	44	COMMERCIAL	\$9.00
ADV476KP35	PRODUCTION	PLASTIC LEAD CHIP CARRIER	44	COMMERCIAL	\$4.50
ADV476KP35-REEL	PRODUCTION	PLASTIC LEAD CHIP CARRIER	44	COMMERCIAL	-
ADV476KP50	PRODUCTION	PLASTIC LEAD CHIP CARRIER	44	COMMERCIAL	\$5.00
ADV476KP50-REEL	PRODUCTION	PLASTIC LEAD CHIP CARRIER	44	COMMERCIAL	-
ADV476KP66	PRODUCTION	PLASTIC LEAD CHIP CARRIER	44	COMMERCIAL	-
ADV476KP66-REEL	PRODUCTION	PLASTIC LEAD CHIP CARRIER	44	COMMERCIAL	-
ADV476KP80	PRODUCTION	PLASTIC LEAD CHIP CARRIER	44	COMMERCIAL	\$7.20
ADV476KP80-REEL	PRODUCTION	PLASTIC LEAD CHIP CARRIER	44	COMMERCIAL	\$7.20

* This price is provided for budgetary purposes as recommended list price in U.S. Dollars per unit in the stated volume. Pricing displayed for Evaluation Boards and Kits is based on 1-piece pricing. View [Pricing and Availability](#) for further information.