

# Customer Information Sheet

DRAWING No.: W2632-00

IF IN DOUBT - ASK



NOT TO SCALE

THIRD ANGLE PROJECTION

ALL DIMENSIONS IN mm

**OBSOLETE**

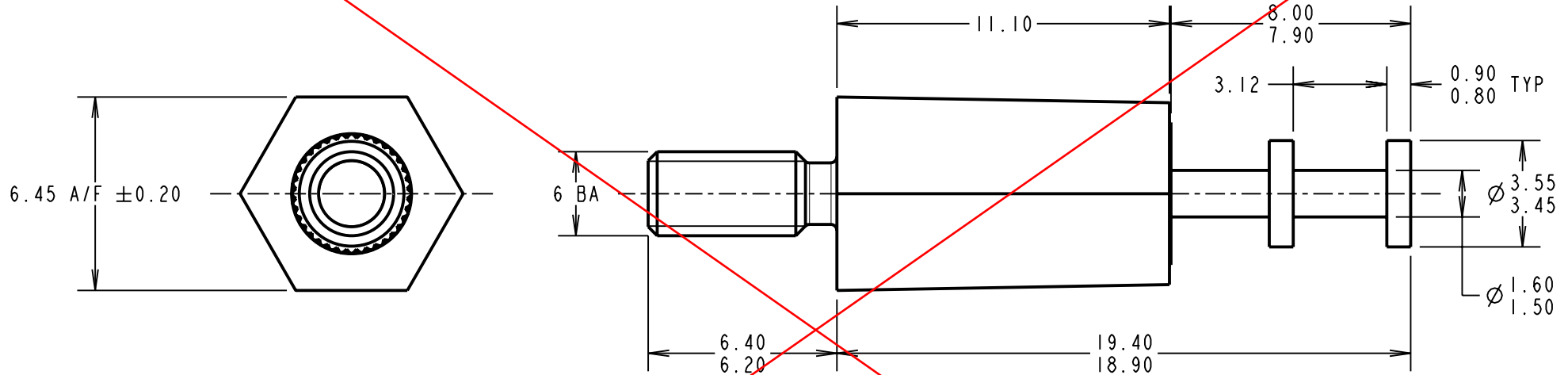

**SPECIFICATIONS:**

**MATERIAL:**

INSULATOR = POLYAMIDE 46, BLACK

INSERTS = BRASS

**FINISH:**

BOTTOM STUD INSERT = 1.25μ NICKEL

DOUBLE TURRET INSERT = 7.6μ 100% TIN OVER 2.4μ NICKEL

**ELECTRICAL:**

CURRENT RATING = 10A MAX

VOLTAGE PROOF = 10kV MIN

**ENVIRONMENTAL:**

OPERATING TEMPERATURE = -55°C TO +125°C

|                        |      |          |        |
|------------------------|------|----------|--------|
| SM                     | 7    | 09.06.10 | 10826  |
| NAME                   | ISS. | DATE     | C/NOTE |
| APPROVED: S. MCCULLAGH |      |          |        |
| CHECKED:               |      | R. ADDE  |        |
| DRAWN:                 |      | K. SHIER |        |
| CUSTOMER REF.:         |      |          |        |
| ASSEMBLY DRG:          |      |          |        |

**HARWIN**

HARWIN USA  
TEL: 603 893 5376  
FAX: 603 893 5396  
mis@harwin.com

HARWIN Europe (UK)  
TEL: 023 9231 4545  
FAX: 023 9231 4590  
mis@harwin.co.uk

HARWIN Asia  
TEL: +65 6 779 4909  
FAX: +65 6 779 3868  
mis@harwin.com.sg

THIS DRAWING AND ANY INFORMATION OR DESCRIPTIVE MATTER SET OUT HEREON ARE CONFIDENTIAL AND COPYRIGHT PROPERTY OF THE HARWIN GROUP AND MUST NOT BE DISCLOSED, LOANED, COPIED OR USED FOR MANUFACTURING, TENDERING OR FOR ANY OTHER PURPOSE WITHOUT THEIR WRITTEN PERMISSION.

**TOLERANCES**  
X. = ±1mm  
X.X = ±0.25mm  
X.XX = ±0.10mm  
X.XXX = ±0.01mm  
**ANGLES = ±5°**  
**UNLESS STATED**

**MATERIAL:**  
SEE ABOVE  
**FINISH:** SEE ABOVE  
**S/AREA:** mm<sup>2</sup>

**TITLE:**  
INSULATED TERMINAL  
DOUBLE TURRET  
**DRAWING NUMBER:**  
W2632-00

SHT  
2  
OF  
2