

Single Stage Flyback or Buck-Boost Current Control with Active PFC for LED lighting

DESCRIPTION

TS19705 is constant current control IC with active power factor correction isolated or non-isolated AC-DC LED lighting control. The TS19705 is configurable as an isolated, primary-side-regulated Flyback controller or non-isolated Buck-Boost converter for LED lighting applications. The IC achieves high power factor and low Total Harmonic Distortion (THD) operation by Boundary Conduction Mode (BCM). The line and load regulation of LED current is about $<\pm 3\%$ because of particular control method. TS19705 also provides gate driving voltage clamping, V_{CC} overvoltage protection and system output open/short circuit protection to increase IC performance.

FEATURES

- Accuracy Constant Current $<\pm 3\%$
- Low BOM Cost
- Flyback or Buck-Boost w/o photocoupler
- Application Voltage Range: $90\sim 264V_{AC}$
- Built-in Active Power Factor Correction
- Good Line and Load Regulation
- Open-LED Protection on DMG pin
- Over-Voltage Protection on V_{CC} pin
- Short-LED Protection
- Cycle by Cycle Over Current Protection on CS pin
- Over-Temperature Protection
- Gate Driving Voltage Clamping

APPLICATION

- LED lighting
- Down lights, Tube lamps, PAR Lamps, Bulbs



SOT-26



Pin Definition:

1. COM
2. GND
3. CS
4. Output
5. V_{CC}
6. DMG

Notes: MSL 3 (Moisture Sensitivity Level) per J-STD-020

TYPICAL APPLICATION CIRCUIT

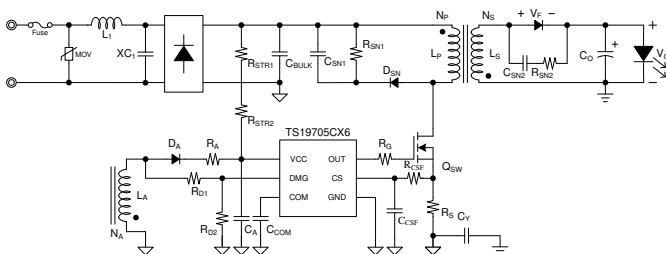

Flyback Converter

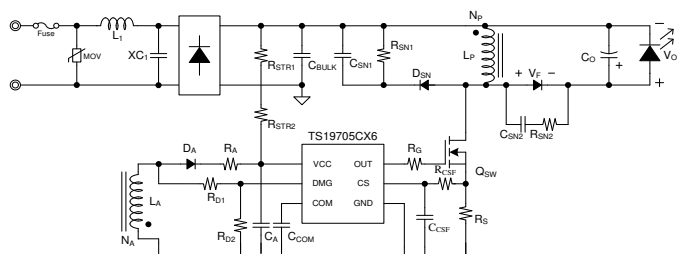

Buck-Boost Converter

ABSOLUTE MAXIMUM RATINGS ($T_A = 25^\circ\text{C}$ unless otherwise specified) ^(Note 1)			
PARAMETER	SYMBOL	LIMIT	UNIT
Power supply pin	V_{CC}	40	V
DMG voltage to GND	V_{DMG}	-0.3 to 40	V
OUT voltage to GND	V_{OUT}	-0.3 to 40	V
CS voltage to GND	V_{CS}	-0.3 to 5.5	V
COM voltage to GND	V_{COM}	-0.3 to 5	V
Junction Temperature Range	T_J	-40 to +150	$^\circ\text{C}$
Storage Temperature Range	T_{STG}	-65 to +150	$^\circ\text{C}$
Power Dissipation @ $T_A=25^\circ\text{C}$	P_D	0.3	W
ESD Rating (Human Body Model)	ESD	2	kV

THERMAL PERFORMANCE ^(Note 3)			
PARAMETER	SYMBOL	TYP	UNIT
Thermal Resistance - Junction to Case	$R_{\theta JC}$	106	$^\circ\text{C/W}$
Thermal Resistance - Junction to Ambient	$R_{\theta JA}$	220	$^\circ\text{C/W}$

RECOMMENDED OPERATING CONDITION ($T_A = 25^\circ\text{C}$ unless otherwise specified) ^(Note 4)			
PARAMETER	SYMBOL	LIMIT	UNIT
Power supply pin	V_{CC}	38	V
DMG voltage to GND	V_{DMG}	-0.3 to 38	V
OUT voltage to GND	V_{OUT}	-0.3 to 38	V
CS voltage to GND	V_{CS}	-0.3 to 5	V
COM voltage to GND	V_{COM}	-0.3 to V_{CC}	V
Operating Junction Temperature Range	T_J	-40 to +125	$^\circ\text{C}$
Operating Ambient Temperature Range	T_{OPA}	-40 to +85	$^\circ\text{C}$

ELECTRICAL SPECIFICATIONS ($T_A = 25^\circ\text{C}$ unless otherwise specified)						
PARAMETER	SYMBOL	CONDITION	MIN	TYP	MAX	UNIT
Supply Voltage						
Turn-on voltage	V_{CC_ON}		17	18	19	V
Turn-off voltage	V_{CC_OFF}		8.5	9.5	10	V
Quiescent current 1	I_{Q1}	$V_{CC}=17\text{V}$, @ V_{CC} off	--	30	50	μA
Quiescent current 2	I_{Q2}	Start-up @ 4.5kHz	--	600	800	μA
Operation supply current	I_{CC}		--	2.5	3.0	mA
Protection						
V_{CC} voltage protection	V_{OVPA}		31	32	34	V
Output voltage protection	V_{OVPS}		10	10.5	11	V
CS limit voltage	V_{OCP}		1.15	1.25	1.35	V
Short circuit protection	V_{SCP}	Guaranteed by design	--	3	--	V
Oscillator						
Start-up timer	t_{STR}		--	220	--	μs

ELECTRICAL SPECIFICATIONS ($T_A = 25^\circ\text{C}$ unless otherwise specified)						
PARAMETER	SYMBOL	CONDITION	MIN	TYP	MAX	UNIT
GM Amplifier						
Transconductance	g_m		--	60	--	$\mu\text{A/V}$
Source current	$I_{\text{COMP_SOU}}$		--	20	--	μA
MOSFET Section						
Dropout voltage	V_{OH}	$V_{\text{CC}}=33\text{V}, I_o = 10\text{mA}$	--	1.2	1.5	V
	V_{OL}	$V_{\text{CC}}=33\text{V}, I_o = -10\text{mA}$	--	0.12	--	V
Rising time	t_r	$V_{\text{CC}}=20\text{V}, C_o = 1\text{nF}$	--	40	--	ns
Falling time	t_f	$V_{\text{CC}}=20\text{V}, C_o = 1\text{nF}$	--	80	--	ns
Output clamp voltage	$V_{\text{O_CLAMP}}$		--	--	19	V
Leading edge blanking time	LEB_t		--	0.5	--	μs

Note:

1. Stresses listed as the above "Absolute Maximum Ratings" may cause permanent damage to the device. These are for stress ratings. Functional operation of the device at these or any other conditions beyond those indicated in the operational sections of the specifications is not implied. Exposure to absolute maximum rating conditions for extended periods may remain possibility to affect device reliability.
2. Devices are ESD sensitive. Handling precaution recommended.
3. Thermal Resistance is specified with the component mounted on a low effective thermal conductivity test board in free air at $T_A=25^\circ\text{C}$.
4. The device is not guaranteed to function outside its operating conditions.
5. Guaranteed by design.
6. Auto Recovery Type.

ORDERING INFORMATION

ORDERING CODE	PACKAGE	PACKING
TS19705CX6 RFG	SOT-26	3,000pcs / 7"Reel

FUNCTION BLOCK

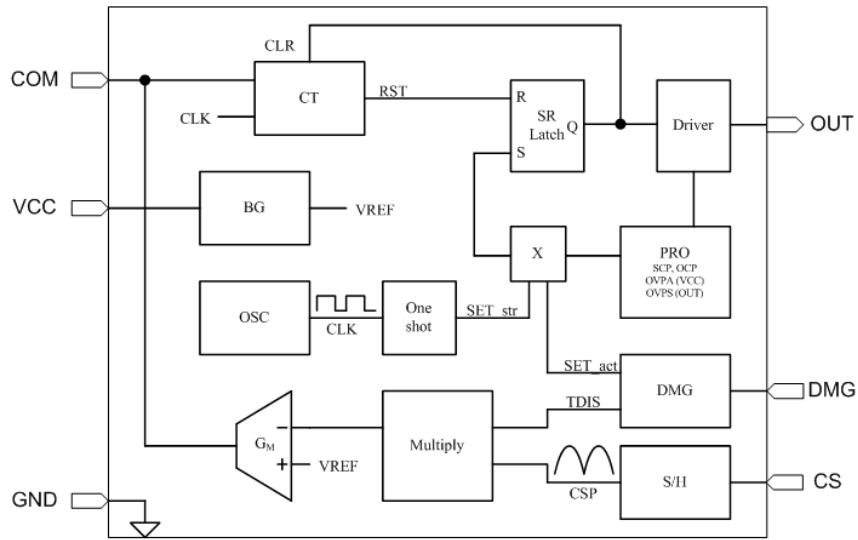

PIN DESCRIPTION

PIN NO.	NAME	FUNCTION
1	COM	Output pin of error amplifier.
2	GND	Ground return for all internal circuitry.
3	CS	Input current sense pin.
4	OUT	Power MOS output pin.
5	V _{CC}	Power supply pin for all internal circuitry.
6	DMG	Zero current demagnetization sensing.

APPLICATION INFORMATION

Function Description

TS19705 is constant current control IC with active power factor correction isolated or non-isolated AC-DC LED lighting control. The TS19705 is configurable as an isolated, primary-side-regulated Flyback controller or non-isolated Buck-Boost converter for LED lighting applications. The controller is Boundary Conduction Mode (BCM) operation with constant on time based regulator design to achieve high power factor performance.

The TS19705 has built-in V_{CC} over voltage protection, open LED protection, short LED protection, over temperature protection, primary side current limit and gate clamp functions.

The average output current can be expressed as below.

$$I_{O_avg} = \frac{N_P}{N_S} \times \frac{0.333 * \eta}{2 * R_S}$$

Where :

- I_{O_avg} is the average output current
- N_P is the primary-side turn ratio
- N_S is the secondary-side turn ratio
- R_S is the sensing resistor connected between the MOSFET source and the GND

Pin Detail

Compensation

This is the output of the g_m amplifier. Connect with a suitable RC network to ground.

Ground

GND is the reference node of internal circuit.

Current Sense

MOSFET current signal sensing for multiplication and current limit setting function.

$$I_{CS (LIMIT)} = \frac{1.25}{R_S}$$

Where :

- I_{CS} is the input current sense
- R_S is the sensing resistor connected between the MOSFET source and GND

Output

Gate drive for external MOSFET switch and is built-in gate clamp function.

V_{CC}

Power supply for the controller during normal operation. The controller will start up when V_{CC} reaches 18V (typical) and will shut-down when V_{CC} voltage is below 9.5V (typical). A decoupling capacitor should be connected between the V_{CC} and GND pin as close as possible.

The TS19705 performs V_{CC} over voltage protection though V_{CC} pin. Once V_{CC} pin exceeds in 32V, TS19705 turns off and latches out the MOSFET switcher until V_{CC} goes below V_{CC_OFF} .

APPLICATION INFORMATION (Continue)

Pin Detail

DMG

The Output voltage is reflected by the auxiliary winding (N_{AUX}) voltage of Flyback transformer, the DMG pin can sense output information to depart from start up voltage (V_{O_STR}) and protection voltage (V_{O_OVP}).

When DMG sense voltage under V_{O_STR} , the circuit will work on short circuit protection, $f_{STR}=1/t_{STR}$.

When DMG sense voltage over V_{O_OVP} , the circuit will work on over voltage protection, it will latches out until V_{CC} goes below V_{CC_OFF} .

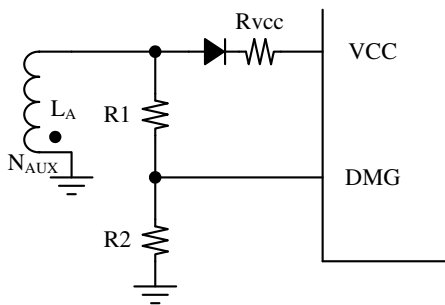

$$V_{O_OVP} = \frac{N_{SEC}}{N_{AUX}} \times V_{OVPS} \times \frac{R1+R2}{R2}$$

$$V_{O_STR} = \frac{N_{SEC}}{N_{AUX}} \times 3 \times \frac{R1+R2}{R2}$$

Where :

- V_{OUT_OVP} is the output-over-voltage protection point
- V_{OVPS} is the over voltage protection signal
- V_{O_STR} is the start-up timer
- N_{AUX} is the number of auxiliary-winding turns
- N_{SEC} is the number of secondary-winding turns

PACKAGE OUTLINE DIMENSIONS (Unit: Millimeters)

SOT-26

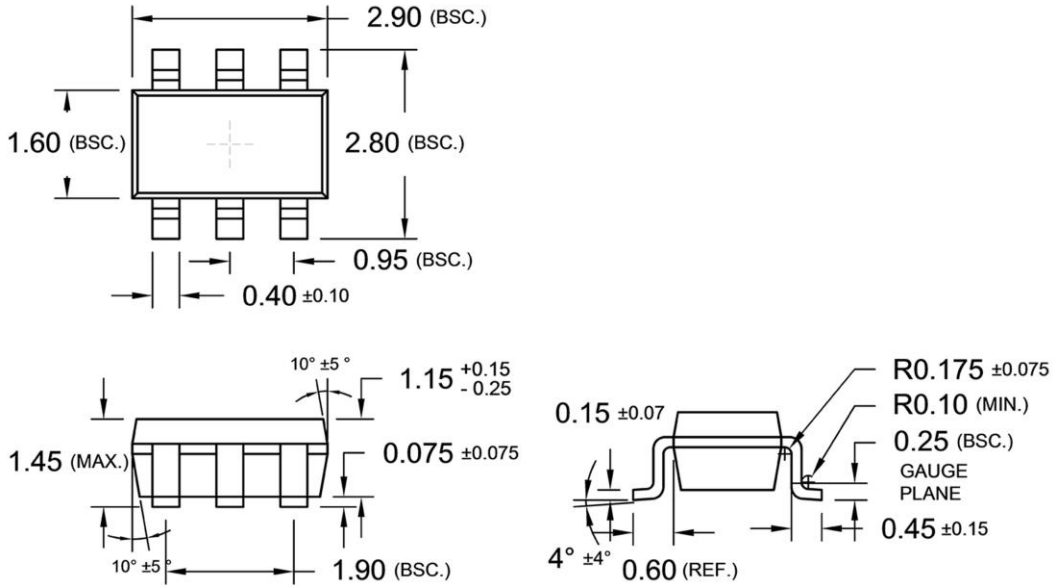

SUGGESTED PAD LAYOUT (Unit: Millimeters)

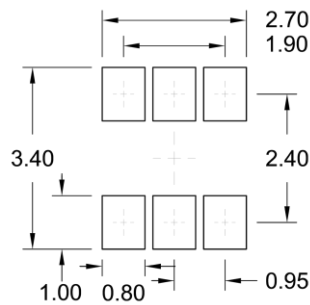

MARKING DIAGRAM

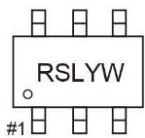

- RS** = Device code
- L** = Lot Code A~Z
- Y** = Year Code
(F=2016, G=2017, H=2018, J=2019, K=2020)
- W** = Week Code
A~Z = wk1~wk26
A~Z = wk27~wk52

Notice

Specifications of the products displayed herein are subject to change without notice. TSC or anyone on its behalf, assumes no responsibility or liability for any errors or inaccuracies.

Information contained herein is intended to provide a product description only. No license, express or implied, to any intellectual property rights is granted by this document. Except as provided in TSC's terms and conditions of sale for such products, TSC assumes no liability whatsoever, and disclaims any express or implied warranty, relating to sale and/or use of TSC products including liability or warranties relating to fitness for a particular purpose, merchantability, or infringement of any patent, copyright, or other intellectual property right.

The products shown herein are not designed for use in medical, life-saving, or life-sustaining applications. Customers using or selling these products for use in such applications do so at their own risk and agree to fully indemnify TSC for any damages resulting from such improper use or sale.