

bq24210 800-mA, Single-Input, Single-Cell Li-Ion Battery Solar Charger

1 Features

- Input Voltage Dynamic Power Management Feature (VBUS_DPM)
- Selectable Battery Tracking Mode to Maximize the Charge Rate from Solar Panel Using DPM Feature
- Load Mode to Support Loads Connected at VBUS Pin
- 20-V Input Rating, With Overvoltage Protection (OVP)
- 1% Battery Voltage Regulation Accuracy
- Current Charge up to 800 mA With 10% Charge Current Accuracy
- Thermal Regulation Protection for Output Current Control
- Low Battery Leakage Current
- BAT Short-Circuit Protection
- NTC Input Monitoring
- Built-In Safety Timer With Reset Control
- Status Indication – Charging/Power Present
- Available in Small 2-mm × 3-mm 10-Pin WSON Package

2 Applications

- Smart Phones
- PDAs
- MP3 Players
- Low-Power Handheld Devices
- Auxiliary Solar Chargers

3 Description

The bq24210 device is a highly integrated Li-Ion linear charger targeted at space-limited portable applications. The battery is charged in three phases: conditioning, constant current and constant voltage with an IC thermal protection and safety timer. The charge current value is programmable through an external resistor. The high input voltage range with input overvoltage protection supports low-cost unregulated adapters. The input voltage regulation loop with programmable input voltage regulation threshold make it suitable for charging from alternative power sources, such as solar panel or inductive charging pad. Furthermore, when no input source is present, the IC has a load mode to power peripherals by connecting the battery to the VBUS. Load mode has current limiting function to prevent overload.

Device Information⁽¹⁾

PART NUMBER	PACKAGE	BODY SIZE (NOM)
bq24210	WSON (10)	2.00 mm × 3.00 mm

(1) For all available packages, see the orderable addendum at the end of the data sheet.

4 Typical Application Schematic

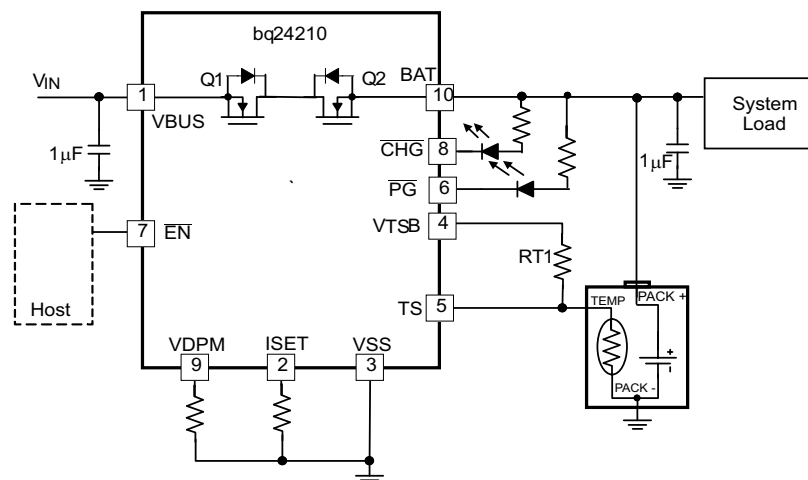

Table of Contents

1 Features	1	8.3 Feature Description.....	11
2 Applications	1	8.4 Device Functional Modes.....	12
3 Description	1	9 Application and Implementation	20
4 Typical Application Schematic	1	9.1 Application Information.....	20
5 Revision History	2	9.2 Typical Application	20
6 Pin Configuration and Functions	3	10 Power Supply Recommendations	22
7 Specifications	4	11 Layout	22
7.1 Absolute Maximum Ratings	4	11.1 Layout Guidelines	22
7.2 ESD Ratings.....	4	11.2 Layout Example	22
7.3 Recommended Operating Conditions.....	4	12 Device and Documentation Support	23
7.4 Thermal Information	5	12.1 Device Support.....	23
7.5 Electrical Characteristics.....	5	12.2 Trademarks	23
7.6 Typical Characteristics	8	12.3 Electrostatic Discharge Caution.....	23
8 Detailed Description	9	12.4 Glossary	23
8.1 Overview	9	13 Mechanical, Packaging, and Orderable Information	23
8.2 Functional Block Diagram	10		

5 Revision History

NOTE: Page numbers for previous revisions may differ from page numbers in the current version.

Changes from Revision A (May 2011) to Revision B	Page
• Added <i>ESD Ratings</i> table, <i>Feature Description</i> section, <i>Device Functional Modes</i> , <i>Application and Implementation</i> section, <i>Power Supply Recommendations</i> section, <i>Layout</i> section, <i>Device and Documentation Support</i> section, and <i>Mechanical, Packaging, and Orderable Information</i> section	1

Changes from Original (December 2010) to Revision A	Page
• Changed from Product Preview to Production Data.....	1
• Changed VBUS description in PIN FUNCTIONS table	3
• Added values to the Thermal Information table.....	5
• Changed titles in Figure 1 and Figure 2	8
• Changed paragraph under Load Mode section	15
• Changed Figure 13	20

6 Pin Configuration and Functions

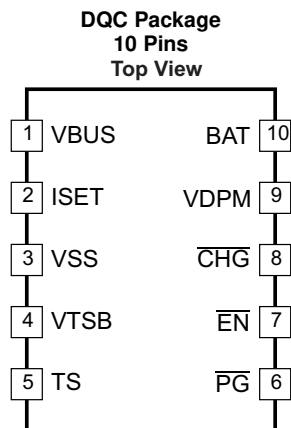

Pin Functions

PIN		I/O	DESCRIPTION
NAME	NO.		
BAT	10	I/O	Battery Connection. System Load may be connected. Expected range of bypass capacitors 1 μ F to 10 μ F, connected from BAT to VSS.
$\overline{\text{CHG}}$	8	O	Charge Status indication, Low (FET ON) indicates charging, and High impedance (open drain FET OFF) in other cases
$\overline{\text{EN}}$	7	I	Chip enable control. Low to enable charge or load mode, and high to enable suspend mode.
ISET	2	I	Programs the Fast-charge current setting. External resistor from ISET to VSS defines fast charge current value.
$\overline{\text{PG}}$	6	O	Power Present indication. LOW (FET ON) When input voltage is in normal range (VBUS>BAT and VBUS>UVLO), High impedance (open drain FET OFF) in other cases.
TS	5	I	Temperature sense pin, connected to NTC Thermistor in the battery pack. Pulling High puts part in limited power charging mode. Must not be left floating.
VBUS	1	I/O	For charging mode, input for charging source, connect to external DC supply (ie, Solar Panel, Inductive charging PAD, or Wall Adapter) For load mode, output for current limited battery voltage. Expected range of bypass capacitors 1 μ F to 10 μ F, connected from VBUS to VSS.
VDPM	9	I	Programs the input voltage regulation threshold. Expected range of programming resistor is 1 k Ω to 10 k Ω , connected from VDPM to VSS. When VDPM is floating, the VIN DPM loop operates in battery tracking mode, and the VIN DPM threshold is BAT+100 mV (BAT>3.6 V) or 3.7 V (BAT \leq 3.6 V) in this case. VIN DPM threshold should be programmed higher than battery voltage to ensure proper operation.
VSS	3	–	Ground terminal
VTSB	4	O	TS bias reference voltage pin, regulated output. No external capacitor is required from VTSB to VSS. Only enabled during charge.
Thermal PAD and Package	–	–	There is an internal electrical connection between the exposed thermal pad and the VSS pin of the device. The thermal pad must be connected to the same potential as the VSS pin on the printed circuit board. Do not use the thermal pad as the primary ground input for the device. VSS pin must be connected to ground at all times.

7 Specifications

7.1 Absolute Maximum Ratings

 over operating temperature range (unless otherwise noted)⁽¹⁾⁽²⁾

		MIN	MAX	UNIT
Input Voltage	VBUS (with respect to VSS)	-0.3	20	V
	BAT (with respect to VSS)	-0.3	7	
	VDPM, VTSB, ISET, TS, \overline{EN} , \overline{CHG} , \overline{PG} (with respect to VSS)	-0.3	7	
Input Current	VBUS		1.25	A
Output Current (Continuous)	BAT		1.25	A
Output Sink Current	\overline{CHG} , \overline{PG}		15	mA
Junction temperature, T _J		-40	150	°C
Storage Temperature, T _{stg}		-65	150	°C

- (1) Stresses beyond those listed under *Absolute Maximum Ratings* may cause permanent damage to the device. These are stress ratings only, and functional operation of the device at these or any other conditions beyond those indicated under *Recommended Operating Conditions* is not implied. Exposure to absolute-maximum-rated conditions for extended periods may affect device reliability.
- (2) All voltage values are with respect to the network ground terminal unless otherwise noted.

7.2 ESD Ratings

		VALUE	UNIT
V _(ESD) Electrostatic discharge	Human body model (HBM), per ANSI/ESDA/JEDEC JS-001 ⁽¹⁾	±3000	V
	Charged-device model (CDM), per JEDEC specification JESD22-C101 ⁽²⁾	±1000	

- (1) JEDEC document JEP155 states that 500-V HBM allows safe manufacturing with a standard ESD control process.
- (2) JEDEC document JEP157 states that 250-V CDM allows safe manufacturing with a standard ESD control process.

7.3 Recommended Operating Conditions

		MIN	MAX	UNIT
VBUS	Voltage range	3.5	18	V
	Operating voltage range, Restricted by UVLO and OVP	3.5	7.0	
IBUS	Input current, VBUS pin		0.8	A
I _{BAT}	Current, BAT pin		0.8	A
T _J	Junction Temperature	0	125	°C
R _{VDPM}	Programs input voltage regulation Thresholds	1k	10k	Ω
R _{ISET}	Fast-charge current programming resistor	675	10.8K	Ω
V _{TS}	Voltage across NTC Thermistor for charging	12	57	%VTSB
C _{BAT}	By-pass capacitor on BAT pin	1	10	μF
C _{VBUS}	By-pass capacitor on VBUS pin	1	10	μF
C _{VTSB}	By-pass capacitor on VTSB pin		0.1	μF

7.4 Thermal Information

THERMAL METRIC ⁽¹⁾		bq24210	UNIT
		DQC	
		10 PINS	
R _{θJA}	Junction-to-ambient thermal resistance	60.7	°C/W
R _{θJC(top)}	Junction-to-case (top) thermal resistance	53.1	
R _{θJB}	Junction-to-board thermal resistance	22.2	
ψ _{JT}	Junction-to-top characterization parameter	0.8	
ψ _{JB}	Junction-to-board characterization parameter	22.1	
R _{θJC(bot)}	Junction-to-case (bottom) thermal resistance	4.7	

(1) For more information about traditional and new thermal metrics, see the *IC Package Thermal Metrics* application report, [SPRA953](#).

7.5 Electrical Characteristics

Over junction temperature range 0°C ≤ T_J ≤ 125°C, V_{BUS}=5 V, charge mode (\overline{EN} = Low) (unless otherwise noted)

PARAMETER	TEST CONDITIONS	MIN	TYP	MAX	UNIT		
INPUT							
V _{UVLO}	Undervoltage lock-out Exit	VBUS: 0 V → 4 V		3.15	3.3	3.45	V
V _{HYS_UVLO}	Hysteresis on V _{UVLO} Falling	VBUS: 4 V → 0 V, V _{UVLO_FALL} = V _{UVLO} - V _{HYS_UVLO}		175	227	280	mV
V _{BUS-DT}	Input Power Good detection threshold VBUS above BAT	(Input power good if VBUS > BAT + V _{BUS-DT}); BAT = 3.6 V, VBUS: 3.5 V → 4 V		150	200	250	mV
V _{HYS-VBUSDT}	Hysteresis on V _{BUS-DT} Falling	BAT = 3.6 V, VBUS: 4 V → 3.5 V			250		mV
t _{DGL(PG_PWR)}	Deglintch time on exiting sleep	Time measured from VBUS: 0 V → 5 V 1-μs rise-time to \overline{PG} = Low, BAT=3.6 V			90		μs
t _{DGL(PG_NO-PWR)}	Deglintch time on V _{HYS-VBUSDT} power down. Same as entering sleep.	Time measured from VBUS: 5 V → 3.2 V 1-μs fall-time to \overline{PG} = Open Circuit			29		ms
V _{OVP}	Input overvoltage protection threshold	VBUS: 5 V → 8 V		7.3	7.5	7.7	V
V _{HYS-OVP}	Hysteresis on OVP	VBUS: 11 V → 5 V			200		mV
t _{BLK(OVP)}	Input overvoltage blanking time	VBUS: 5 V → 12 V			113		μs
t _{DGL(PG_OVP)}	Deglintch time exiting OVP	Time measured from VBUS: 12 V → 5 V 1-μs fall-time to \overline{PG} = Low			5		ms
V _{BUS-DPM}	Input voltage regulation threshold. Restricts I _{out} at V _{BUS-DPM}	Programmable, the programming resistor at VDPM pin R _{VDPM} = 1kΩ		3.55	3.65	3.75	V
		Programmable, the programming resistor at VDPM pin R _{VDPM} = 10kΩ		4.8	5	5.1	
KVBUS_DPM	Term Factor	BAT > V _{LOWV} , VBUS = 5 V, R _{VDPM} = 1 kΩ to 10 kΩ; R _{VDPM} = KVBUS_DPM × (VBUS_DPM - VBUS_DPM_1)		0.135	0.15	0.165	V/KΩ
VBUS_DPM_1	Initial voltage for VBUS_DPM threshold setting	BAT > V _{LOWV} , VBUS = 5 V, R _{VDPM} = 1 kΩ to 10 kΩ		3.41	3.5	3.59	V
VBUS_DPM_0	VBUS_DPM threshold when VDPM is shorted to VSS	BAT > V _{LOWV} , VBUS = 5 V, R _{VDPM} < 500 Ω			3.65		V
IVBUS_DPM	Current for programming VBUS_DPM				75		μA
V _{TRK}	Battery voltage tracking threshold for VBUS DPM loop	VDPM pin Float (open circuit, R _{TS} > 500 kΩ), BAT rising	BAT ≤ 3.6 V	3.65	3.7	3.75	V
			BAT > 3.6 V	BAT +0.07	BAT +0.10	BAT +0.145	
V _{TRK_HYS}	Hysteresis for V _{TRK}	BAT falling			60		mV
V _{BUS_CHG}	Input voltage to enable \overline{CHG} pin, VBUS-V _{BUS_DPM} or VBUS-V _{TRK}	\overline{EN} =LOW, VBUS rising above VIN DPM threshold			80		mV
V _{BUS_CHG_HYS}	Hysteresis for V _{BUS_CHG}	\overline{EN} =LOW, VBUS falling			160		mV
t _{DGL_CHG}	Deglintch time for \overline{CHG} pin status change				5		mS

Electrical Characteristics (continued)

 Over junction temperature range $0^{\circ}\text{C} \leq T_J \leq 125^{\circ}\text{C}$, $V_{\text{BUS}}=5\text{ V}$, charge mode ($\overline{\text{EN}} = \text{Low}$) (unless otherwise noted)

PARAMETER		TEST CONDITIONS	MIN	TYP	MAX	UNIT
ISET SHORT CIRCUIT TEST						
$R_{\text{ISET_MAX}}$	Highest Resistor value considered a fault (short). Monitored for $I_{\text{OUT}} > 90\text{mA}$	Riset: $600\ \Omega \rightarrow 250\ \Omega$, I_{OUT} latches off. Cycle power to Reset. Fault range $> 1.10\ \text{A}$	200	250	300	Ω
$t_{\text{DGL_SHORT}}$	Deglintch time transition from ISET Short to Iout Disable	Clear fault by cycling IN or $\overline{\text{CHGEN}}$		1		ms
$I_{\text{OUT_CL}}$	Maximum OUT current limit regulation (Clamp)		0.95		1.4	A
BATTERY SHORT PROTECTION						
$I_{\text{BAT(SC)}}$	Source current out BAT pin during short-circuit detection		13	17	21	mA
$\text{BAT}_{(\text{SC})}$	BAT pin short-circuit detection threshold/ Pre-Charge Threshold	$\text{BAT}: 3\ \text{V} \rightarrow 0.5\ \text{V}$, no deglitch	0.75	0.8	0.85	V
$\text{BAT}_{(\text{SC-HYS})}$	BAT pin Short Hysteresis	Recovery $\rightarrow \text{BAT}_{(\text{SC})} + \text{BAT}_{(\text{SC-HYS})}$; Rising, no Deglitch		77		mV
QUIESCENT CURRENT						
$I_{\text{OUT(DONE)}}$	BAT pin current, charging terminated	$\overline{\text{EN}} = \text{Low}$, $V_{\text{BUS}} = 6\ \text{V}$, Terminated			9	μA
$I_{\text{OUT(STDBY)}}$	Suspend current into BAT pin	$\overline{\text{EN}} = \text{High}$, $V_{\text{BUS}} = 0\ \text{V}$, $\text{BAT} = 4.2\ \text{V}$			5	μA
$I_{\text{BUS(STDBY)}}$	Suspend current into VBUS pin	$\overline{\text{EN}} = \text{High}$, $V_{\text{BUS}} \leq 6\ \text{V}$		100	175	μA
I_{CC}	Active supply current, VBUS pin	No load on VTSB pin, $\overline{\text{EN}} = \text{Low}$, $V_{\text{BUS}} = 6\ \text{V}$, no load on BAT pin, $\text{BAT} > V_{\text{O(REG)}}$, IC enabled		0.8	1.2	mA
$I_{\text{CC_REV}}$	Active supply current, BAT pin in load mode	$\overline{\text{EN}} = \text{Low}$, $\text{BAT} = 4\ \text{V}$, no load on VBUS pin		50	80	μA
BATTERY CHARGER FAST-CHARGE						
$V_{\text{O(REG)}}$	Battery regulation voltage	$V_{\text{BUS}} = 5.5\ \text{V}$, $I_{\text{OUT}} = 25\ \text{mA}$, ($V_{\text{TS_0C}} < V_{\text{TS}} < V_{\text{TS_45C}}$)	4.16	4.20	4.23	V
$V_{\text{O_HT(REG)}}$	Battery hot regulation Voltage	$V_{\text{BUS}} = 5.5\ \text{V}$, $I_{\text{OUT}} = 25\ \text{mA}$, ($V_{\text{TS_45C}} < V_{\text{TS}} < V_{\text{TS_60C}}$)	4.02	4.06	4.1	
I_{OUT}	Programmed output "fast charge" current range	$V_{\text{O(REG)}} > \text{BAT} > V_{\text{LOWV}}$, $V_{\text{BUS}} = 5\ \text{V}$, $R_{\text{ISET}} = 469\ \text{to}\ 7.5\ \text{k}\Omega$	50		800	mA
$V_{\text{DO(IN-OUT)}}$	Drop-Out, VBUS – BAT	Adjust VBUS down until $I_{\text{OUT}} = 0.5\ \text{A}$, $\text{BAT} = 4.15\ \text{V}$, $R_{\text{ISET}} = 675$, $T_J < 100^{\circ}\text{C}$.		250	400	mV
I_{OUT}	Output "fast charge" formula	$V_{\text{O(REG)}} > \text{BAT} > V_{\text{LOWV}}$, $V_{\text{BUS}} = 5\ \text{V}$		$K_{\text{ISET}}/R_{\text{ISET}}$		A
K_{ISET}	Fast charge current factor	$R_{\text{ISET}} = K_{\text{ISET}}/I_{\text{OUT}}$; $250\ \text{mA} \leq I_{\text{OUT}} < 800\ \text{mA}$	373	390	407	A Ω
		$R_{\text{ISET}} = K_{\text{ISET}}/I_{\text{OUT}}$; $50\ \text{mA} \leq \text{ICHG} < 250\ \text{mA}$	375	395	416	
		$R_{\text{ISET}} = K_{\text{ISET}}/I_{\text{OUT}}$; $10 < \text{ICHG} < 50\ \text{mA}$	320	400	490	
PRECHARGE – INTERNALLY SET						
V_{LOWV}	Pre-charge to fast-charge transition threshold		2.4	2.5	2.6	V
$t_{\text{DGL1(LOWV)}}$	Deglitch time on pre-charge to fast-charge transition			100		μs
$t_{\text{DGL2(LOWV)}}$	Deglitch time on fast-charge to pre-charge transition			32		ms
$I_{\text{PRE-CHG}}$	Pre-charge current, Internally set	$\text{BAT} < V_{\text{LOWV}}$, $\text{ICHG} \geq 250\ \text{mA}$	18	20	22	% IOUT
TERMINATION – INTERNALLY SET						
I_{TERM}	Termination current, Internally set	$\text{ICHG} \geq 250\ \text{mA}$	8	10	12	% ICHG
$t_{\text{DGL(TERM)}}$	Deglitch time, termination detected			29		ms
RECHARGE OR REFRESH						
V_{RCH}	Recharge detection threshold- normal temp	$V_{\text{TS_0C}} < V_{\text{TS}} < V_{\text{TS_45C}}$, $\text{BAT}: 4.2\ \text{V} \rightarrow V_{\text{RCH}}$	$V_{\text{O(REG)}} - 0.120$	$V_{\text{O(REG)}} - 0.095$	$V_{\text{O(REG)}} - 0.070$	V
	Recharge detection threshold-hot temp	$V_{\text{TS_45C}} < V_{\text{TS}} < V_{\text{TS_60C}}$, $\text{BAT}: 4.15\ \text{V} \rightarrow V_{\text{RCH}}$	$V_{\text{O(REG)}} - 0.130$	$V_{\text{O(REG)}} - 0.105$	$V_{\text{O(REG)}} - 0.80$	V
$t_{\text{DGL1(RCH)}}$	Deglitch time, recharge threshold detected	$V_{\text{TS_0C}} < V_{\text{TS}} < V_{\text{TS_45C}}$, $\text{BAT}: 4.25\ \text{V} \rightarrow 3.5\ \text{V}$ in $1\ \mu\text{s}$; $t_{\text{DGL(RCH)}}$ is time to ISET ramp		29		ms

Electrical Characteristics (continued)

 Over junction temperature range $0^{\circ}\text{C} \leq T_J \leq 125^{\circ}\text{C}$, $V_{\text{BUS}}=5\text{ V}$, charge mode ($\overline{\text{EN}} = \text{Low}$) (unless otherwise noted)

PARAMETER		TEST CONDITIONS	MIN	TYP	MAX	UNIT
$t_{\text{DGL2(RCH)}}$	Deglitch time, recharge threshold in BAT_Detect mode	$V_{\text{TS}_0\text{C}} < V_{\text{TS}} < V_{\text{TS}_45\text{C}}$, BAT: 3.5 V inserted; $t_{\text{DGL(RCH)}}$ is time to ISET ramp		3.6		ms
BATTERY DETECTION ROUTINE						
$V_{\text{REG_BD}}$	BAT Reduced regulation during battery detect	$V_{\text{TS}_0\text{C}} < V_{\text{TS}} < V_{\text{TS}_45\text{C}}$, Battery present	$V_{\text{O(REG)}}$ -0.45	$V_{\text{O(REG)}}$ -0.4	$V_{\text{O(REG)}}$ -0.35	V
$V_{\text{BD_SINK}}$	Sink current during $V_{\text{REG_BD}}$	$V_{\text{TS}_0\text{C}} < V_{\text{TS}} < V_{\text{TS}_45\text{C}}$, Battery present	5	7	9	mA
$t_{\text{DGL1(HI/LOW_REG)}}$	Regulation time at V_{REG} or $V_{\text{REG_BD}}$	$V_{\text{TS}_0\text{C}} < V_{\text{TS}} < V_{\text{TS}_45\text{C}}$, Battery present		25		ms
$V_{\text{BD_HI}}$	High battery detection threshold	$V_{\text{TS}_0\text{C}} < V_{\text{TS}} < V_{\text{TS}_45\text{C}}$, Battery present	$V_{\text{O(REG)}}$ -0.158	$V_{\text{O(REG)}}$ -0.108	$V_{\text{O(REG)}}$ -0.058	V
$V_{\text{BD_LO}}$	Low battery detection threshold	$V_{\text{TS}_0\text{C}} < V_{\text{TS}} < V_{\text{TS}_45\text{C}}$, Battery present	$V_{\text{REG_BD}}$ +0.05	$V_{\text{REG_BD}}$ +0.1	$V_{\text{REG_BD}}$ +0.15	V
BATTERY CHARGING TIMERS AND FAULT TIMERS						
t_{PRECHG}	Pre-charge safety timer value	Restarts when entering Pre-charge; Always enabled when in pre-charge. $V_{\text{TS}} < V_{\text{SM(TS)}}$	1700	1940	2250	s
t_{MAXCH}	Charge safety timer value	Clears fault or resets at UVLO, $\overline{\text{EN}}$ disable, BAT Short, exiting LOWV and Refresh	34000	38800	45000	s
t_{MAXTERM}	Termination timer in limited power charge mode	Limited power charge mode, terminate charge when VIN DPM active, normal termination conditions met and this timer expires	6800	7760	9000	s
BATTERY-PACK NTC MONITOR						
V_{TSB}	TS Bias Voltage	$I_{\text{VTSB}} < 1\text{ mA}$	2	2.2	2.4	V
$I_{\text{VTSB (Min)}}$	Maximum current from TS-bias pin (short circuit protection)				1	mA
C_{VTSB}	Optional capacitance for ESD				0.1	μF
C_{TS}	Optional capacitance for ESD			0.22		μF
$V_{0\text{C}}$				57		%VTSB
$V_{0\text{C-Hyst}}$	Hysteresis on 0C comparator			1		%VTSB
$V_{10\text{C}}$				46		%VTSB
$V_{10\text{C-Hyst}}$	Hysteresis on 10C comparator			1		%VTSB
$V_{45\text{C}}$				18.6		%VTSB
$V_{45\text{C-Hyst}}$	Hysteresis on 45C comparator			1		%VTSB
$V_{60\text{C}}$				12		%VTSB
$V_{60\text{C-Hyst}}$	Hysteresis on 60C comparator			1		%VTSB
$t_{\text{DGL(TS}_10\text{C)}}$	Deglitch for TS thresholds: 10C	Normal to cold operation: V_{TS} : 30% \rightarrow 50% VTSB		50		ms
		Cold to Normal operation: V_{TS} : 50% \rightarrow 30% VTSB		12		
$t_{\text{DGL(TS)}}$	Deglitch for TS thresholds: 10/45/60C	Battery charging		30		ms
$V_{\text{LP(TS)}}$	Limited power charge mode threshold - Enter	V_{TS} : 0.4VTSB \rightarrow 0.9VTSB;	75	80	85	%VTSB
$V_{\text{HYS-LP(TS)}}$	Hysteresis exiting limited power charge mode	V_{TS} : 1.7 V \rightarrow 0.5 V;		5		
$t_{\text{DGL(LDO)}}$	Deglitch exit limited power charge mode between states	Battery charging		57		ms
	Deglitch enter limited power charge mode between states			8		μs
THERMAL REGULATION						
$T_{\text{J(REG)}}$	Temperature regulation limit			125		$^{\circ}\text{C}$
$T_{\text{J(OFF)}}$	Thermal shutdown temperature			155		$^{\circ}\text{C}$
$T_{\text{J(OFF-HYS)}}$	Thermal shutdown hysteresis			20		$^{\circ}\text{C}$

Electrical Characteristics (continued)

Over junction temperature range $0^{\circ}\text{C} \leq T_J \leq 125^{\circ}\text{C}$, $\text{VBUS}=5\text{ V}$, charge mode ($\overline{\text{EN}} = \text{Low}$) (unless otherwise noted)

PARAMETER		TEST CONDITIONS	MIN	TYP	MAX	UNIT
LOGIC LEVELS ON $\overline{\text{EN}}$						
V_{IL}	Logic LOW input voltage	Sink $8\ \mu\text{A}$			0.4	V
V_{IH}	Logic HIGH input voltage	Source $8\ \mu\text{A}$	1.4			V
I_{IL}	Sink current required for LO		2		10.5	μA
I_{IH}	Source current required for HI		0.8		2	μA
LOGIC LEVELS ON $\overline{\text{CHG}}$ AND $\overline{\text{PG}}$						
V_{OL}	Output LOW voltage	$I_{\text{SINK}} = 5\ \text{mA}$			0.4	V
I_{LEAK}	Leakage current into IC	$V_{\text{chg}} = 5\ \text{V}$, $\text{VPG} = 5\ \text{V}$			1	μA
LOAD MODE ($\overline{\text{EN}}=\text{LOW}$)						
$\text{BAT}_{\text{REV_ST}}$	Minimum voltage for load mode		2.8	3.0	3.2	V
$V_{\text{DO(BAT-VBUS)}}$	Drop-Out, $V(\text{BAT}) - V(\text{VBUS})$	Adjust VBUS down until $I(\text{VBUS}) = 0.1\ \text{A}$, $\text{BAT} = 4.15\ \text{V}$, $T_J < 100^{\circ}\text{C}$.		200	320	mV
$V_{\text{BUS-LM}}$	Load mode exiting threshold (VBUS above BAT)	$\text{BAT} = 3.6\ \text{V}$, VBUS : rising $3\ \text{V} \rightarrow 4\ \text{V}$	-100	-50	0	mV
$V_{\text{HYS-VBUSLM}}$	Hysteresis on $V_{\text{BUS-LM}}$ falling	$\text{BAT} = 3.6\ \text{V}$, VBUS : $4\ \text{V} \rightarrow 3\ \text{V}$		150		mV
$t_{\text{DGL(LM_Exit)}}$	Deglitch time on exiting load mode			100		mS
$t_{\text{DGL(LM_Enter)}}$	Deglitch time on $V_{\text{HYS-VBUSLM}}$ same as entering load mode			5		μs
$I_{\text{LM_MIN}}$	The minimum load current to keep IC in load mode	During load mode	0.3	1.8	3.1	mA
$I_{\text{REV_LIMIT}}$	Initial current limit in load mode for blanking time $t_{\text{REV_LIMIT_BLK}}$	$\text{BAT} = 3.6\ \text{V}$	130	170	215	mA
$t_{\text{REV_LIMIT_BLK}}$	Blanking time for initial current limit			200		ms
$I_{\text{REV_LIMIT_BK}}$	Reverse load mode current limit after the initial blanking time		40	55	70	mA
$t_{\text{REV_LIMIT_REC}}$	Delay time to set load current limit back to $I_{\text{REV_LIMIT}}$	Reverse current drops from 100% to 30% of $I_{\text{REV_LIMIT_BK}}$		200		ms

7.6 Typical Characteristics

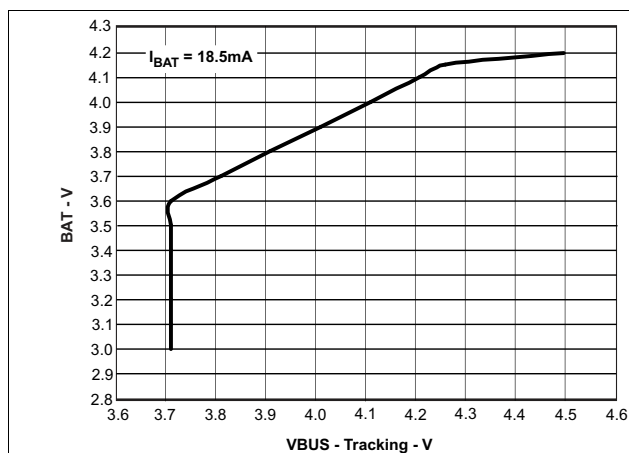

Figure 1. Tracking vs BAT

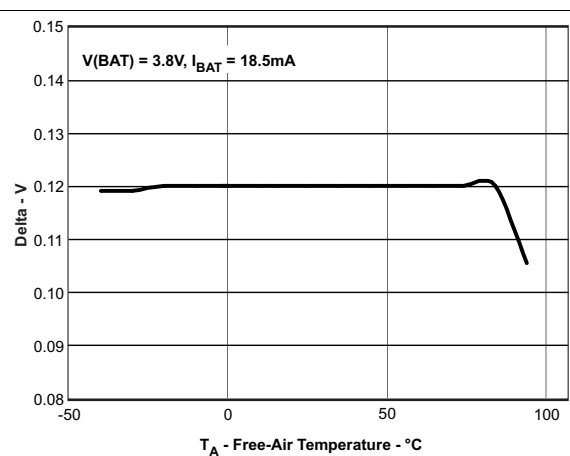

Figure 2. Tracking vs Temperature

8 Detailed Description

8.1 Overview

The bq24210 is a highly integrated 2-mm x 3-mm² single-cell Li-Ion charger with bidirectional power flow capability. Depending on the status of control pins and source conditions, the IC can operate in several modes: sleep, charge, load, and suspend mode.

At power up (VBUS or BAT ramps up, or \overline{EN} pin changes status), the IC performs the operation mode detection automatically. Depending on the VBUS and BAT levels, the IC enters sleep, charge, load, or suspend mode.

In charge mode, the charger has three phases of charging: Pre-charge to recondition a full discharged battery, fast-charge constant current to supply the buck charge safely and voltage regulation to safely reach full capacity, as shown in Figure 3. The charge operating mode is very flexible, allowing programming of the fast-charge current, and input voltage regulation threshold. The programmable input voltage regulation threshold makes the IC compatible with both low impedance power sources, like USB ports or wall adapters, or high impedance sources such as solar panel or thermo-electric generators.

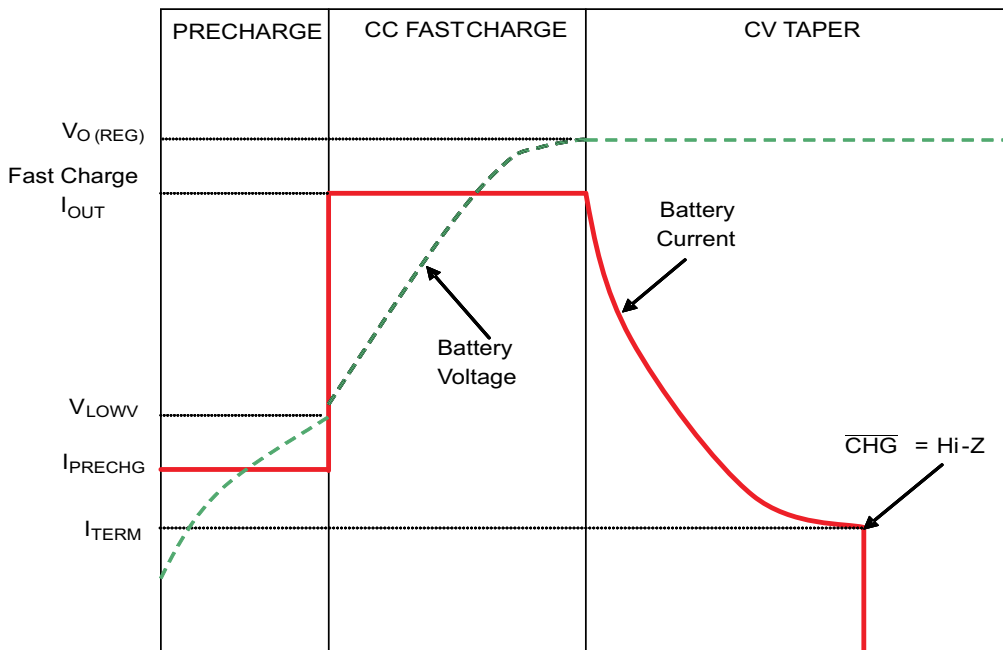

Figure 3. Charge Profile

In load mode, the IC connects the battery voltage to the input pin (VBUS pin) through the back to back FET (Q1 and Q2) to power the load connected at VBUS pin. The load current is limited to provide overload protection.

In sleep mode, Q2 is OFF and the IC standby current is reduced to I_{CC_REV} .

In suspend mode, the IC turns off both Q1 and Q2, and no charging or reverse conduction is allowed.

8.2 Functional Block Diagram

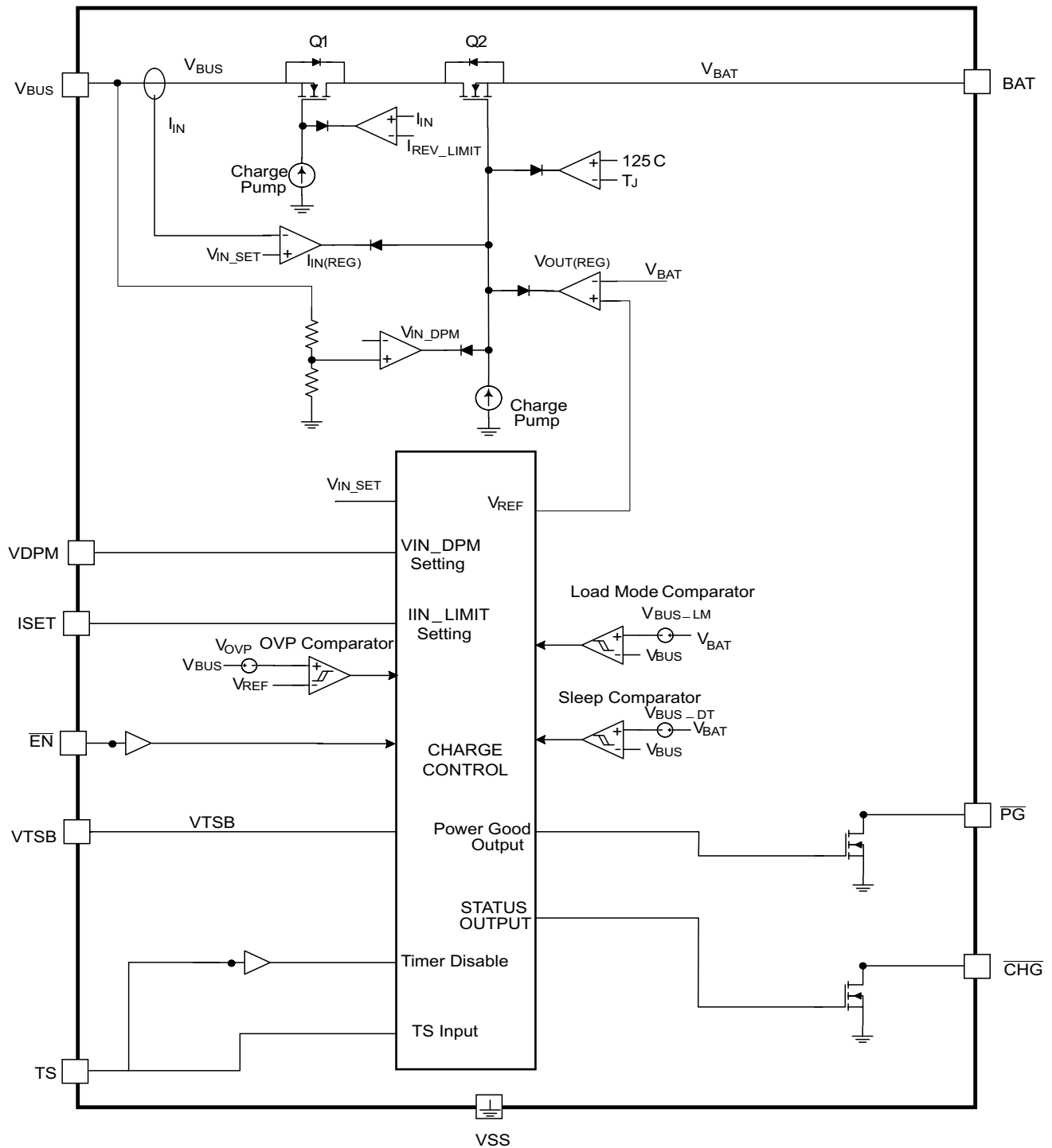

8.3 Feature Description

8.3.1 Input Voltage-Based Dynamic Power Management (VBUS-DPM)

The VBUS-DPM feature is used to detect an input source voltage that is reaching its current limit due to excessive load and causing the voltage to reduce. When the input voltage drops to the VBUS-DPM threshold the internal pass FET reduces the current until there is no further drop in voltage at the input. This prevents a source with voltage less than VBUS_{DPM} to power the BAT pin. This unique feature makes the IC work well with current limited (for example, high impedance) power sources, such as solar panels or inductive charging pads. This is also an added safety feature that helps protect the source from excessive loads.

An external resistor is used to program the VBUS_{DPM}. The programming resistor, R_{VDPM} is dictated by the following equation:

$$R_{VDPM} = (VBUS_{DPM} - VBUS_{DPM_1}) / K_{VBUS_DPM}$$

where

- VBUS_{DPM} is the desired input voltage regulation voltage threshold;
- VBUS_{DPM_1} is the built in offset threshold, typically 3.5 V
- K_{VBUS_DPM} is a gain factor found in the electrical specification. (1)

If VDPM pin is shorted to VSS, the VBUS_{DPM} is set to typically 3.65 V.

If the VDPM pin is floated (open circuit), the IC operates in battery tracking mode. In this case, VBUS DPM threshold is internally set as V_{TRK}, which is typically BAT+100 mV (BAT>3.65 V) or 3.75 V (BAT≤3.4 V).

8.3.2 \overline{CHG} Pin Indication

The charge pin has an internal open drain FET which is on (pulls down to V_{SS}) during the first charge only (unless TS pin is tied to VTSB pin) and is turned off once the battery reaches voltage regulation and the charge current tapers to the internally set termination threshold.

The charge pin is high impedance in sleep mode and OVP (if \overline{PG} is high impedance) and return to its previous state once the condition is removed.

Cycling input power, toggling \overline{EN} pin, or releasing or entering pre-charge mode causes the \overline{CHG} pin to go low if power is good and a discharged battery is attached. This is considered the start of a first charge cycle.

8.3.3 \overline{CHG} and \overline{PG} LED Pull-Up Source

For host monitoring, a pullup resistor is used between the STATUS pin and the V_{CC} of the host. For a visual indication a resistor in series with an LED is connected between the STATUS pin and a power source. If the \overline{CHG} or \overline{PG} source is capable of exceeding 7 V, a 6.2-V Zener diode should be used to clamp the voltage. If the source is the BAT pin, note that as the battery changes voltage, the brightness of the LEDs vary.

Table 1. \overline{CHG}

CHARGING STATE	\overline{CHG} FET/LED (V _{TS} < V _{LP(TS)})	\overline{CHG} FET/LED (V _{TS} > V _{LP(TS)})
1 st Charge	ON	ON
Refresh Charge	OFF	ON
OVP		OFF
Sleep		OFF
TEMP Fault	ON for 1 st Charge	ON
Charge when BAT< BAT _(SC)	OFF	ON

Table 2. \overline{PG}

INPUT POWER GOOD STATE	\overline{PG} FET/LED
Normal Input (BAT+VBUS _{DT} <VBUS<V _{OVP}) and (VBUS _{DPM} <V _{BUS} <V _{OVP})	ON

Table 2. $\overline{\text{PG}}$ (continued)

INPUT POWER GOOD STATE	$\overline{\text{PG}}$ FET/LED
UVLO	OFF
Sleep Mode	
OVP Mode	
$\overline{\text{PG}}$ is independent of chip disable	

8.3.4 Power Good Indication ($\overline{\text{PG}}$)

After a source is applied to VBUS and the voltage rises above the UVLO and sleep thresholds ($\text{VBUS} > \text{BAT} + V_{\text{BUS-DT}}$) and VBUS-DPM threshold ($V_{\text{BUS-DPM}}$ or V_{TRK}), but is less than OVP ($\text{VBUS} < V_{\text{OVP}}$), then the $\overline{\text{PG}}$ FET turns on and provides a low impedance path to ground. The EN pin state does not affect this functionality.

8.4 Device Functional Modes

8.4.1 Power-Down or Undervoltage Lockout (UVLO)

The IC is in power down mode if the VBUS and BAT pin voltages are both less than UVLO. The part is considered "dead" and all the pins are high impedance. Once the VBUS voltage rises above the UVLO threshold the IC enters sleep mode or an active mode depending on control pin status and the BAT pin (battery) voltage.

8.4.2 Operation Mode Detection and Transition

On power up (VBUS or BAT ramps up, or $\overline{\text{EN}}$ pin changes status), the IC performs operation mode detection to identify the operation mode based on the VBUS voltage, battery voltage, load current, and control pin status.

Two comparators are needed for the detection, load mode comparator and sleep mode comparator.

When VBUS falls below the lower limit of the load mode comparator, the IC goes to load mode; when VBUS is above the upper limit of the sleep comparator, the IC goes to charge mode, as shown in [Figure 4](#).

Device Functional Modes (continued)

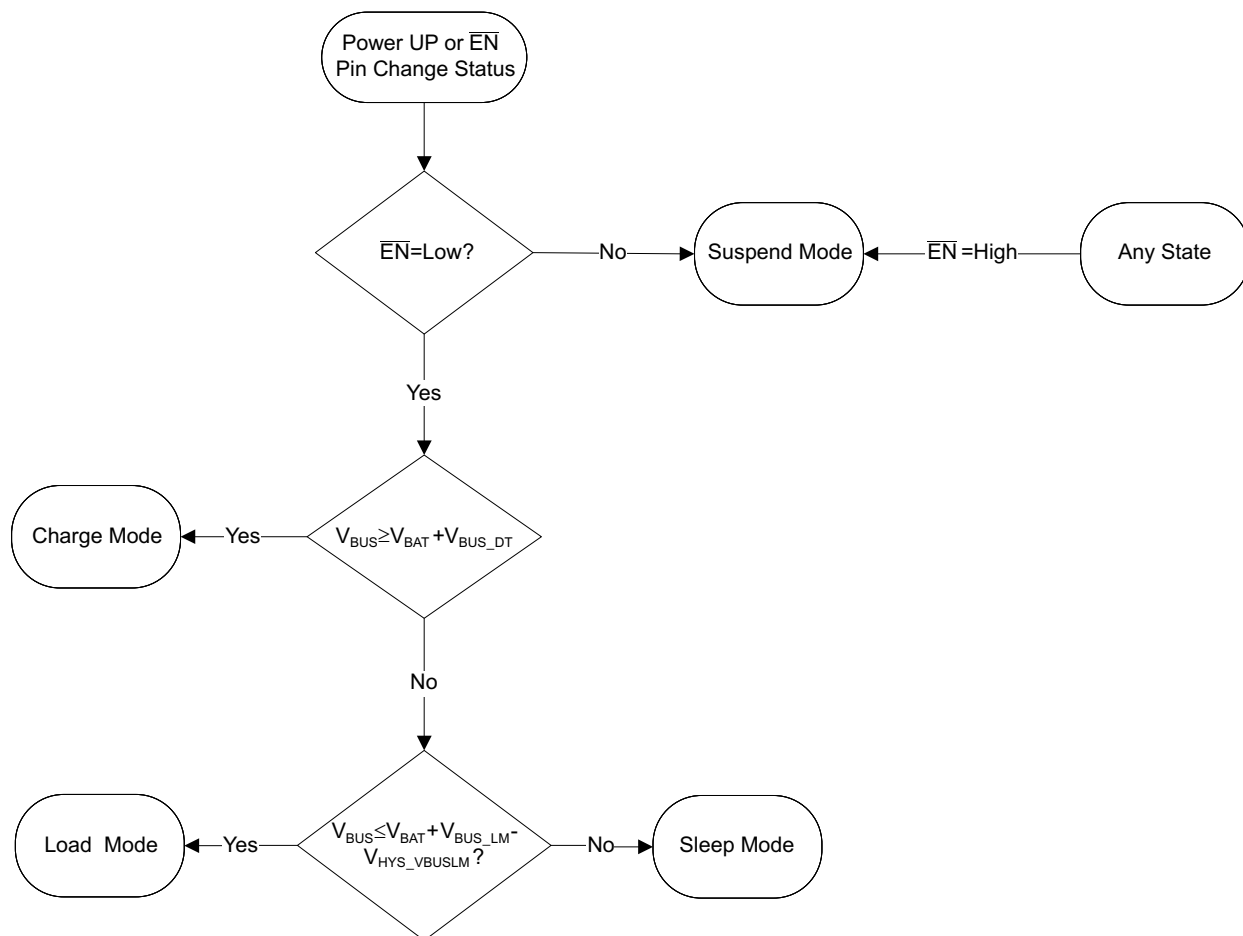

Figure 4. Operation Mode Detection Flow Chart

During load mode, when VBUS is above upper limit of load mode and the load current is below the minimum load current (I_{LM_MIN}), the IC stays in load mode for a deglitch time of 100 mS and then goes to sleep mode.

If VBUS is above the upper limit of the sleep comparator during this period, after 45- μ s deglitch time, the IC stops load mode and goes into the charge mode. The maximum current to the battery is limited by the FET RDSon during this transition.

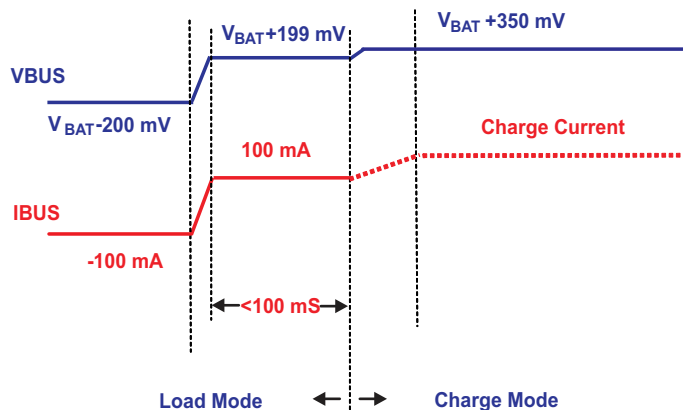

Figure 5. Sleep Comparator Operation

Device Functional Modes (continued)

During charge mode, if V_{BUS} falls to the lower limit of sleep comparator, the IC goes to sleep mode after a deglitch time of 32 mS. If V_{BUS} falls faster than 32 ms to below the lower limit of load mode comparator, the IC goes to load mode after a deglitch time of 32 ms, as shown in Figure 6.

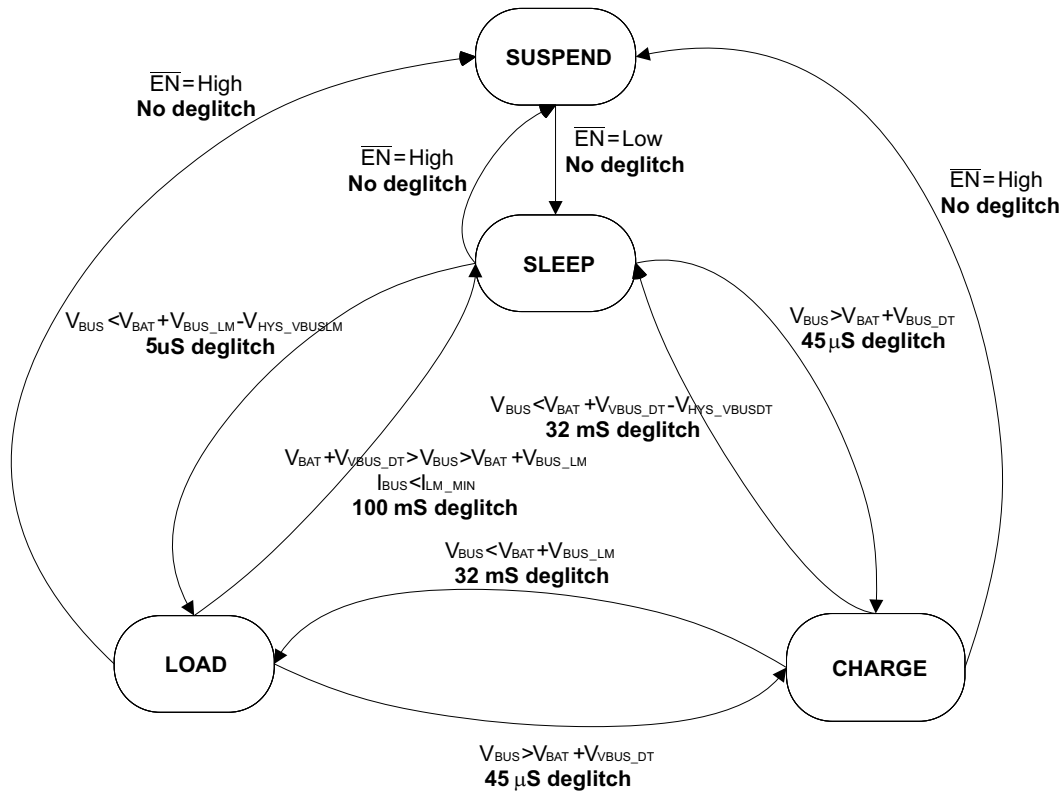

Figure 6. Operation Mode Transition Diagram

In load mode, if the load is higher than I_{LM_MIN}, or the voltage at V_{BUS} pin is lower than upper limit of load mode comparator, load mode is continuous.

If the load is smaller than I_{LM_MIN} in load mode, and V_{BUS} is higher than the upper limit, then the IC goes to sleep mode after deglitch time of 100 mS. In sleep mode, once V_{BUS} drops lower than the lower limits of the load mode comparator, the IC goes to load mode again. In this case, the above process repeats, and IC keeps changing operations mode (between sleep mode and load mode). The mode change frequency is less than 10 Hz, and V_{BUS} has a ripple of 150 mV.

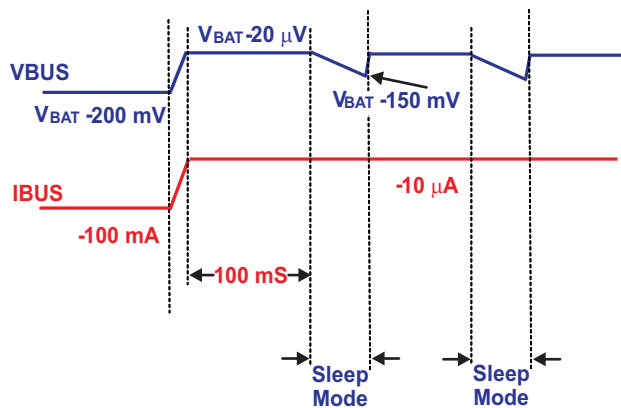

Figure 7. Load Mode Operation

Device Functional Modes (continued)

8.4.3 Sleep Mode

If the VBUS pin voltage is below the BAT voltage and above the UVLO threshold, the charge current is disabled, the safety timer counting pauses (not reset) and the $\overline{\text{PG}}$ and $\overline{\text{CHG}}$ pins are high impedance. As the input voltage rises and the charger exits sleep mode, the $\overline{\text{PG}}$ pin goes low, the safety timer continues to count, charge is enabled, and the $\overline{\text{CHG}}$ pin remains high impedance until current flows out the BAT pin.

8.4.4 Load Mode

Load mode is used when the charging source is removed and an external accessory needs power from the battery.

To start the load mode, the minimum BAT pin voltage is $\text{BAT}_{\text{REV_ST}}$. When load mode is active, the oscillator and charge pump will operate at reduced speed to reduce quiescent current prolonging battery life.

During load mode, reverse current is monitored, and once it rises to an internally set threshold, $I_{\text{REV_LIMIT}}$, the load current regulation loop will limit the load current to the threshold for a blanking time of $t_{\text{REV_LIMIT_BLK}}$. If the overload condition continues after the blanking time of $t_{\text{REV_LIMIT_BLK}}$, the load current limit threshold will be reduced to $I_{\text{REV_LIMIT_BK}}$ (about 50mA) and load mode continues, until the VBUS drops below UVLO or other failure occurs. If the load current drops below $I_{\text{REV_LIMIT_BK}}$, the load current limit will be set back to $I_{\text{REV_LIMIT}}$ after a delay of $t_{\text{REV_LIMIT_REC}}$, as shown in Figure 8.

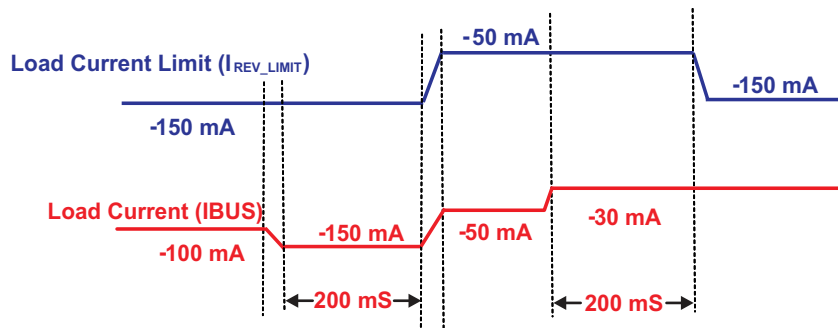

Figure 8. Load Current Limiting

8.4.5 Charge Mode

8.4.5.1 Overvoltage Protection (OVP) – Continuously Monitored

If the input source applies an overvoltage, the pass FET, if previously on, turns off after a deglitch, $t_{\text{BLK(OVP)}}$. The timer ends and the $\overline{\text{CHG}}$ and $\overline{\text{PG}}$ pins go to a high impedance state. Once the overvoltage returns to a normal voltage and after a deglitch time of $t_{\text{DGL(PG_OVP)}}$, the $\overline{\text{PG}}$ pin goes low, timer continues, charge continues, and the $\overline{\text{CHG}}$ pin goes low after a 25-ms deglitch.

8.4.5.2 Power Up

The IC is alive after the VBUS or BAT voltage ramps above UVLO (see sleep mode), the IC resets all logic and timers, and starts to perform many of the continuous monitoring routines. Typically the input voltage quickly rises through the UVLO and sleep states where the IC declares power good, starts the safety timer, enables the $\overline{\text{CHG}}$ pin, and starts the normal charge routine.

8.4.5.3 Battery Detect Routine

The battery detect routine checks for a missing battery while keeping the BAT pin at a useable voltage. Whenever the battery is missing, the $\overline{\text{CHG}}$ pin is high impedance.

The battery detect routine is run when entering and exiting LPCM to verify if battery is present, or run all the time if battery is missing. On power-up, if battery voltage is greater than V_{RCH} threshold, a battery detect routine is run to determine if a battery is present.

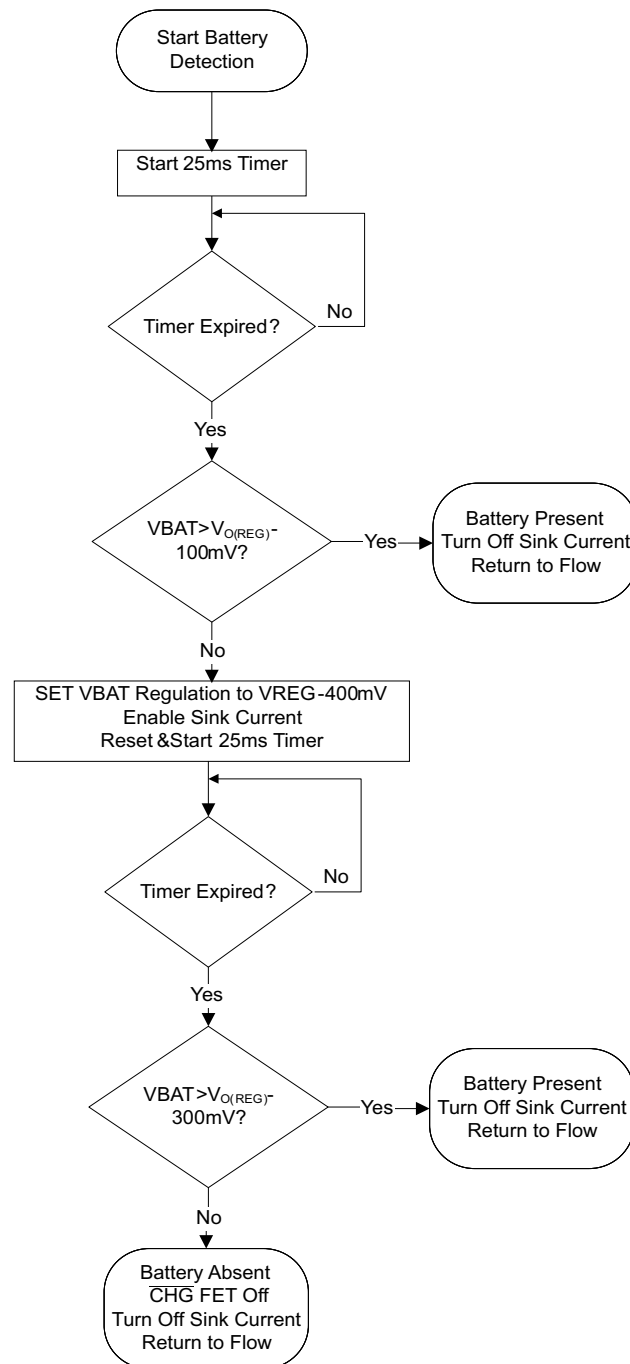
Device Functional Modes (continued)

Figure 9. Battery Detection Flow Chart
8.4.5.4 New Charge Cycle

A new charge cycle is started when a good power source is applied, when performing a charge disable/enable ($\overline{\text{EN}}$), when exiting limited power charge mode (LPCM), when detecting a battery insertion, or when the BAT voltage dropping below the VRCH threshold. The $\overline{\text{CHG}}$ pin is active low only during the first charge cycle, therefore exiting LPCM or dropping below VRCH will not turn on the $\overline{\text{CHG}}$ pin FET, if the $\overline{\text{CHG}}$ pin is already high impedance.

Device Functional Modes (continued)

8.4.5.5 BAT Output

The charger's BAT pin provides current (I_{OUT}) to the battery and to the system, if present. This IC can be used to charge the battery plus power the system or charge just the battery assuming the loads do not exceed the available current. The BAT pin is a current limited source and is inherently protected against shorts. If the system load ever exceeds the output programmed current threshold, the output voltage will drop unless there is sufficient capacitance or a charged battery present to supplement the excessive load. If the voltage on BAT drops below the pre-charge to fast-charge threshold, $V_{LOWV} = 2.5$ V typical, I_{OUT} is reduced to 10% typical of the fast charge current.

8.4.5.6 Fast Charge Current (I_{OUT})

An external resistor on the ISET pin is used to program the output current (50 to 800mA) and can be used as a current monitor.

$$R_{ISET} = K_{ISET} / I_{OUT}$$

where

- I_{OUT} is the desired fast charge current in amps;
- K_{ISET} is a gain factor found in the electrical specification, typically 395 A Ω (2)

The ISET resistor is short protected and will detect a resistance lower than R_{ISET_MAX} . The detection requires at least 80mA of output current. If a *short* is detected, then the IC will latch off and can only be reset by cycling the power. The BAT current is internally clamped to a maximum current I_{OUT_CL} which is independent of the ISET short detection circuitry.

8.4.5.7 Termination

Once the BAT pin goes above V_{RCH} (reaches voltage regulation), and the current tapers down to the termination threshold (20% of the fast charge current), the \overline{CHG} pin goes high impedance, and a battery detect route is run to determine if the battery was removed or the battery is full. If the battery is present, the charge current will terminate. If the battery was removed along with the thermister, then the TS pin is driven high and the charger enters LPCM. If the battery was removed and the TS pin is held in the active region, then the battery detect routine will continue until a battery is inserted. After termination, if the BAT pin voltage drops to V_{RCH} (100mV below regulation) while input power remains applied then a new charge is initiated, but the \overline{CHG} pin remains at a high impedance (off). The termination threshold is raised by 14%, for the first minute of a charge cycle so if a full battery is removed and reinserted or a new charge cycle is initiated, that the new charge terminates (less than 1 minute). Batteries that have relaxed many hours may take several minutes to taper to the termination threshold and terminate charge.

8.4.5.8 Timers

The pre-charge timer is set to 30 minutes. The fast charge timer is fixed at 10 hours and can be increased real time by going into thermal regulation or V_{BUS_DPM} . While in thermal regulation or V_{BUS_DPM} , the timer clock slows by a factor of 2, resulting in a clock that counts half as fast which will increase the total time. If either the 30 minute or ten hour timer times out, the charging is terminated and the \overline{CHG} pin goes high impedance if not already in that state. The timer is reset by disabling the IC, cycling power, or going into and out of LPCM.

8.4.5.9 Battery Temperature Monitoring

When connected to a thermistor that monitors the battery's temperature, the TS feature prevents battery damage by reducing charge current or voltage at battery temperature extremes. The TS feature is designed to be compatible with the JEITA temperature standard for Li-Ion batteries. There are four thresholds, 60°C, 45°C, 10°C, and 0°C. Normal operation occurs between 10°C and 45°C. If between 0°C and 10°C, the charge current level is cut in half and if between 45°C and 60°C, the regulation voltage is reduced to 4.1Vmax.

The voltage based TS sensing is used due to the flexibility to be compatible with different NTCs. V_{TSB} is used as the voltage reference for TS sensing, and two external TS voltage divider (RT1 and RTH) are used to set the targeted temperature threshold. Above 60°C or below 0°C the charge is disabled.

Device Functional Modes (continued)

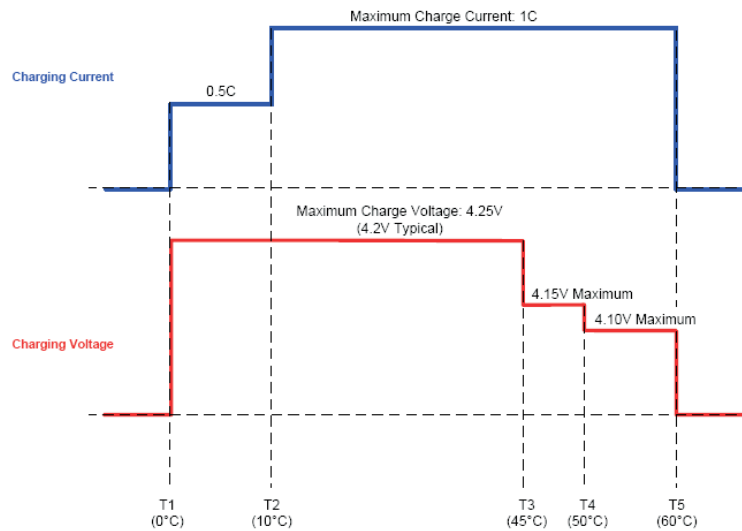

Figure 10. Charge JEITA Profile

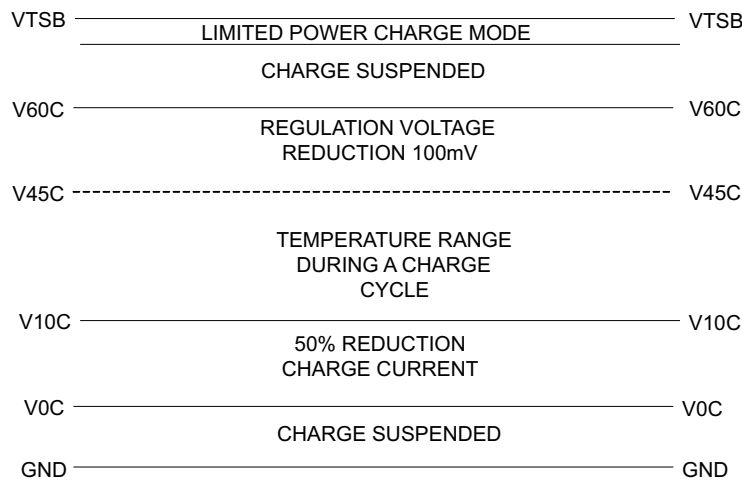

Figure 11. TS Pin, Thermister Sense Thresholds

Assuming a 103AT NTC thermister on the battery pack as shown in [Figure 13](#), the value RT1 can be determined by using the following equation (select the most critical temperature for the best precision):

$$RT1 = \frac{1}{V_{V45C}} \times R_{TH}(45C) - R_{TH}(45C) \tag{3}$$

Device Functional Modes (continued)

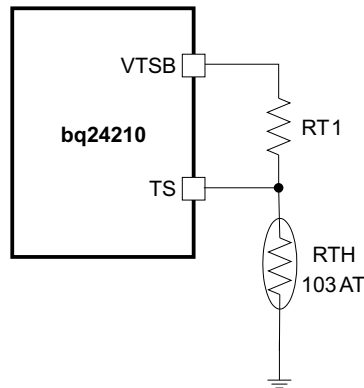

Figure 12. TS Resistor Network

The TS pin has another additional feature. When the TS pin is driven high ($V_{TS} > V_{LP(TS)}$), the IC operates in limited power charge mode.

8.4.5.10 Limited Power Charge Mode – TS Pin High

When the TS pin goes high to the limited power charge mode (LPCM) threshold ($V_{LP(TS)}$), the part enters limited power charge mode. This mode is used normally for solar charging applications or other high impedance input sources that desire to modify the termination routine and other timers. When entering the limited power charging mode, the pre-charge timer and 10 hour safety timer is held in reset, and the termination routine is modified. A battery detect routine is run to see if the battery was removed or not. If the battery was removed then the \overline{CHG} pin will go to its high impedance state if not already there. If a battery is detected, the normal charge process begins. If the normal termination conditions are met ($I_{charge} < I_{TERM}$, $BAT > V_{RCH}$) and V_{BUS_DPM} loop is not active, the charging process terminates, and the \overline{CHG} pin goes to its high impedance state if not already there. When the regular timers are disabled there still is a 2 hour timer if the part is stuck in DPM above 4.1 V but outside of termination conditions at which point charging will terminate and re-start if the voltage falls below 4.1V.

When coming out of the limited power charging mode, the battery detect routine is run and if a battery is detected, then a new charge cycle begins and the \overline{CHG} LED turns on.

Limited power charge mode is not necessary for all solar charging. A solar panel charging in normal mode without TS pulled high would keep the normal termination timers active and would allow the TS temperature monitoring functions to be used.

If limited power charging mode is not desired upon removal of the battery with a thermister, apply a voltage equal to 30% VTSB on TS pin using two external resistors to set a voltage divider and disable the TS monitor function.

8.4.6 Suspend Mode

When \overline{EN} pin is pulled to HIGH level, the IC operates in suspend mode, with Q1 and Q2 OFF and very low leakage current into and between VBUS and BAT pins. The PG pin continues to operate to indicate a good power source even while in suspend mode.

9 Application and Implementation

NOTE

Information in the following applications sections is not part of the TI component specification, and TI does not warrant its accuracy or completeness. TI's customers are responsible for determining suitability of components for their purposes. Customers should validate and test their design implementation to confirm system functionality.

9.1 Application Information

Although it can be powered from low impedance sources like a USB port or wall adapter, this IC's VBUS-DPM feature makes it ideal to be powered from high impedance sources like solar panels or inductor charging pads.

9.2 Typical Application

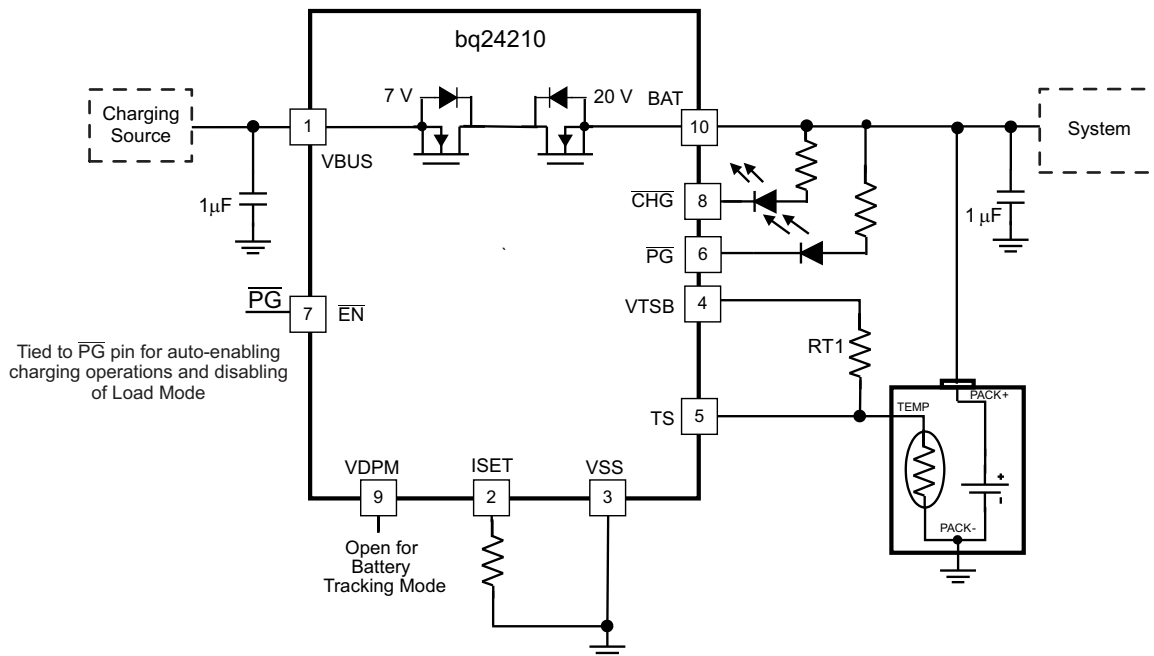

Figure 13. Typical System Schematic

9.2.1 Design Requirements

A solar panel with $V_{OC} = 6\text{ V}$ in direct sunlight and capable of up to 1 W of output power is available to charge a 500 mAHr Lilon battery at a 1C rate. Because the light intensity will vary over time, this application uses the IC in battery tracking mode. The IC will never use load mode so \overline{EN} is tied to \overline{PG} .

9.2.2 Detailed Design Procedure

The minimum recommend capacitors of 1 μF for VBUS and BAT are used. The pullup resistors for \overline{CHG} and \overline{PG} are 2 k Ω .

Using $R_{ISET} = K_{ISET} / I_{OUT}$ and set $I_{OUT} = I_C = 500\text{mA}$ gives $R_{ISET} = 390\text{ A}\Omega / 500\text{ mA} = 780\text{ }\Omega \rightarrow 787\text{ }\Omega$ closest 1% resistor.

Using Equation 3 and finding $R_{TH}(45)$ from the 103AT-4 thermistor datasheet as 4911 Ω , $RT1 = 1 / (0.186) * 4911\text{ }\Omega - 4911\text{ }\Omega = 21.492\text{ k}\Omega \rightarrow 21.5\text{ k}\Omega$ closest 1% resistor.

For battery tracking mode, we leave V_{DPM} floating. If we decided to power the charger using a 5-V wall adapter that a minimum output voltage of 4.6 V, we would size a resistor V_{DPM} to ground using $R_{VDPM} = (V_{BUS_DPM} - V_{BUS_DPM_1}) / K_{VBUS_DPM} = (4.6\text{ V} - 3.5\text{ V}) / (0.15\text{ V/k}\Omega) = 7.333\text{ k}\Omega \rightarrow 7.32\text{ k}\Omega$ closest 1% resistor.

Typical Application (continued)

9.2.3 Application Curves

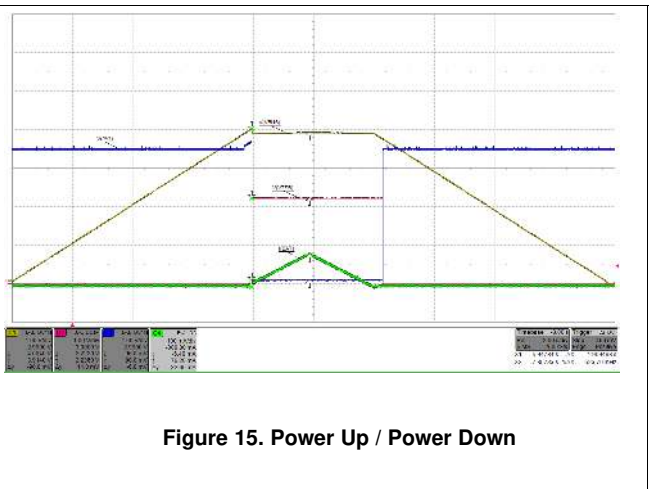
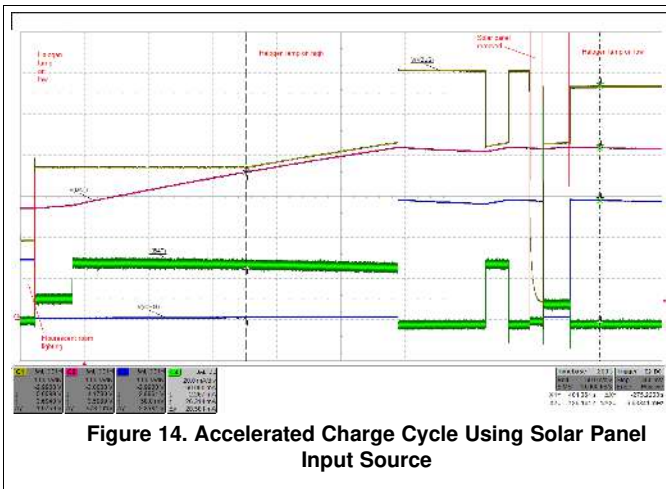

10 Power Supply Recommendations

In order for the IC to charge a battery, the power source at VBUS must be larger than the undervoltage lockout threshold of 3.3 V typical and the battery voltage, V(BAT) plus 200 mV typical to prevent SLEEP mode but less than the OVP threshold of 7.5 V typical. The input power source can be a low impedance USB port or wall adapter or a high impedance solar panel if the VBUS_DPM feature is appropriately configured.

11 Layout

11.1 Layout Guidelines

The minimum VBUS and BAT capacitors, CVBUS and CBAT, of 1 uF are required to be placed as close as possible between the respective pins and the IC ground pin. Higher bulk capacitance values and additional high frequency (< 0.1 uF) bypass capacitors are allowed. Next, the resistor on ISET, Riset, and on VDPM, RVDPM, should be placed as close as possible to the respective pins and the IC ground pin. The TS pullup resistor, RVTSB or RT1, can then be placed between the VTSB and TS pins. Optional capacitors up to 1.0 uF on TS, CTS, and VTSB, CVTSB, can be placed to minimize noise coupling.

11.2 Layout Example

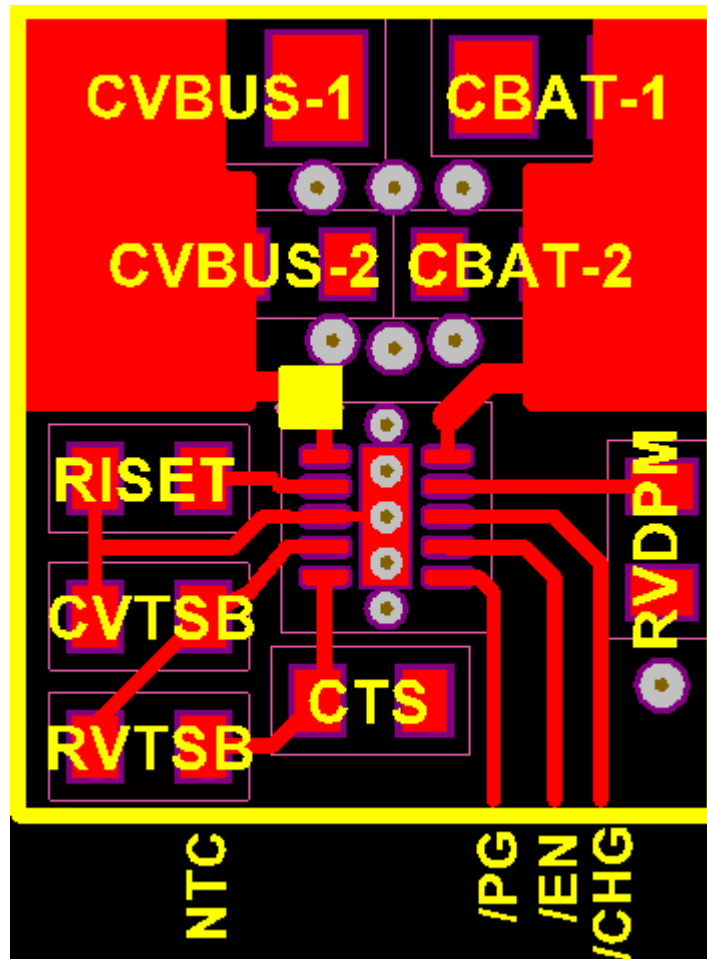

Figure 16. Recommended Layout

12 Device and Documentation Support

12.1 Device Support

12.1.1 Third-Party Products Disclaimer

TI'S PUBLICATION OF INFORMATION REGARDING THIRD-PARTY PRODUCTS OR SERVICES DOES NOT CONSTITUTE AN ENDORSEMENT REGARDING THE SUITABILITY OF SUCH PRODUCTS OR SERVICES OR A WARRANTY, REPRESENTATION OR ENDORSEMENT OF SUCH PRODUCTS OR SERVICES, EITHER ALONE OR IN COMBINATION WITH ANY TI PRODUCT OR SERVICE.

12.2 Trademarks

All trademarks are the property of their respective owners.

12.3 Electrostatic Discharge Caution



These devices have limited built-in ESD protection. The leads should be shorted together or the device placed in conductive foam during storage or handling to prevent electrostatic damage to the MOS gates.

12.4 Glossary

[SLYZ022](#) — *TI Glossary*.

This glossary lists and explains terms, acronyms, and definitions.

13 Mechanical, Packaging, and Orderable Information

The following pages include mechanical, packaging, and orderable information. This information is the most current data available for the designated devices. This data is subject to change without notice and revision of this document. For browser-based versions of this data sheet, refer to the left-hand navigation.

PACKAGING INFORMATION

Orderable Device	Status (1)	Package Type	Package Drawing	Pins	Package Qty	Eco Plan (2)	Lead finish/ Ball material (6)	MSL Peak Temp (3)	Op Temp (°C)	Device Marking (4/5)	Samples
BQ24210DQCR	ACTIVE	WSON	DQC	10	3000	RoHS & Green	NIPDAU	Level-2-260C-1 YEAR	-40 to 85	QXI	Samples
BQ24210DQCT	ACTIVE	WSON	DQC	10	250	RoHS & Green	NIPDAU	Level-2-260C-1 YEAR	-40 to 85	QXI	Samples

(1) The marketing status values are defined as follows:

ACTIVE: Product device recommended for new designs.

LIFEBUY: TI has announced that the device will be discontinued, and a lifetime-buy period is in effect.

NRND: Not recommended for new designs. Device is in production to support existing customers, but TI does not recommend using this part in a new design.

PREVIEW: Device has been announced but is not in production. Samples may or may not be available.

OBSOLETE: TI has discontinued the production of the device.

(2) **RoHS:** TI defines "RoHS" to mean semiconductor products that are compliant with the current EU RoHS requirements for all 10 RoHS substances, including the requirement that RoHS substance do not exceed 0.1% by weight in homogeneous materials. Where designed to be soldered at high temperatures, "RoHS" products are suitable for use in specified lead-free processes. TI may reference these types of products as "Pb-Free".

RoHS Exempt: TI defines "RoHS Exempt" to mean products that contain lead but are compliant with EU RoHS pursuant to a specific EU RoHS exemption.

Green: TI defines "Green" to mean the content of Chlorine (Cl) and Bromine (Br) based flame retardants meet JS709B low halogen requirements of <=1000ppm threshold. Antimony trioxide based flame retardants must also meet the <=1000ppm threshold requirement.

(3) MSL, Peak Temp. - The Moisture Sensitivity Level rating according to the JEDEC industry standard classifications, and peak solder temperature.

(4) There may be additional marking, which relates to the logo, the lot trace code information, or the environmental category on the device.

(5) Multiple Device Markings will be inside parentheses. Only one Device Marking contained in parentheses and separated by a "~" will appear on a device. If a line is indented then it is a continuation of the previous line and the two combined represent the entire Device Marking for that device.

(6) Lead finish/Ball material - Orderable Devices may have multiple material finish options. Finish options are separated by a vertical ruled line. Lead finish/Ball material values may wrap to two lines if the finish value exceeds the maximum column width.

Important Information and Disclaimer:The information provided on this page represents TI's knowledge and belief as of the date that it is provided. TI bases its knowledge and belief on information provided by third parties, and makes no representation or warranty as to the accuracy of such information. Efforts are underway to better integrate information from third parties. TI has taken and continues to take reasonable steps to provide representative and accurate information but may not have conducted destructive testing or chemical analysis on incoming materials and chemicals. TI and TI suppliers consider certain information to be proprietary, and thus CAS numbers and other limited information may not be available for release.

In no event shall TI's liability arising out of such information exceed the total purchase price of the TI part(s) at issue in this document sold by TI to Customer on an annual basis.

TAPE AND REEL INFORMATION



QUADRANT ASSIGNMENTS FOR PIN 1 ORIENTATION IN TAPE



*All dimensions are nominal

Device	Package Type	Package Drawing	Pins	SPQ	Reel Diameter (mm)	Reel Width W1 (mm)	A0 (mm)	B0 (mm)	K0 (mm)	P1 (mm)	W (mm)	Pin1 Quadrant
BQ24210DQCR	WSON	DQC	10	3000	180.0	8.4	2.25	3.25	1.05	4.0	8.0	Q1
BQ24210DQCT	WSON	DQC	10	250	180.0	8.4	2.25	3.25	1.05	4.0	8.0	Q1

TAPE AND REEL BOX DIMENSIONS

*All dimensions are nominal

Device	Package Type	Package Drawing	Pins	SPQ	Length (mm)	Width (mm)	Height (mm)
BQ24210DQCR	WSON	DQC	10	3000	210.0	185.0	35.0
BQ24210DQCT	WSON	DQC	10	250	210.0	185.0	35.0

GENERIC PACKAGE VIEW

DQC 10

WSON - 0.8 mm max height

PLASTIC SMALL OUTLINE - NO LEAD

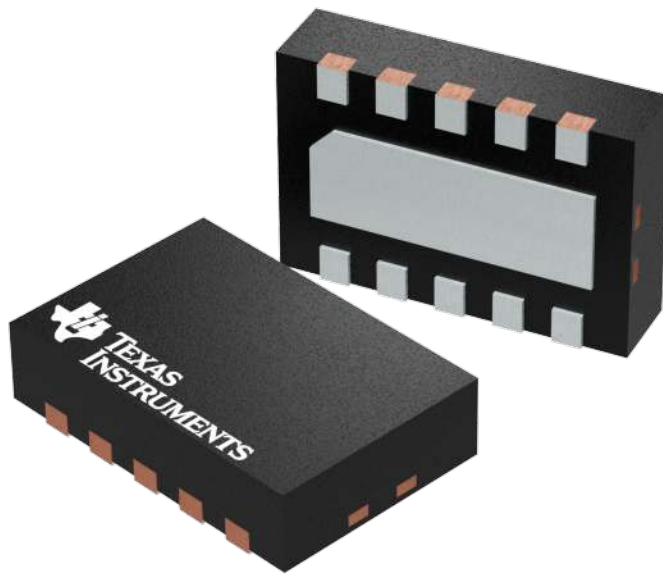

Images above are just a representation of the package family, actual package may vary.
Refer to the product data sheet for package details.

4209674/B

EXAMPLE BOARD LAYOUT

DQC0010A

WSON - 0.8mm max height

PLASTIC SMALL OUTLINE - NO LEAD

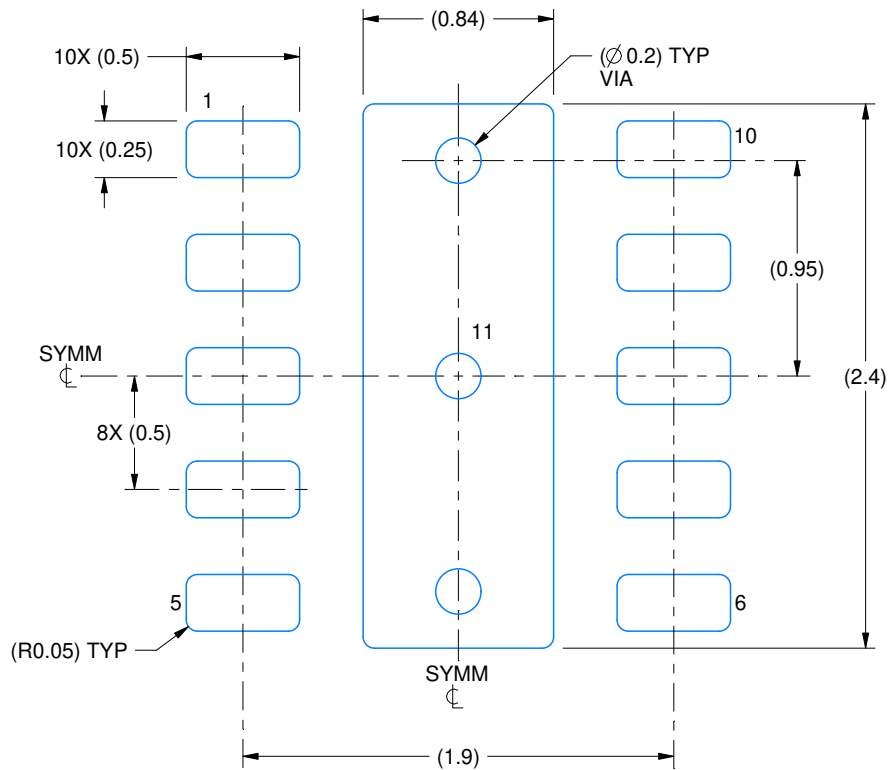

LAND PATTERN EXAMPLE
SCALE: 30X

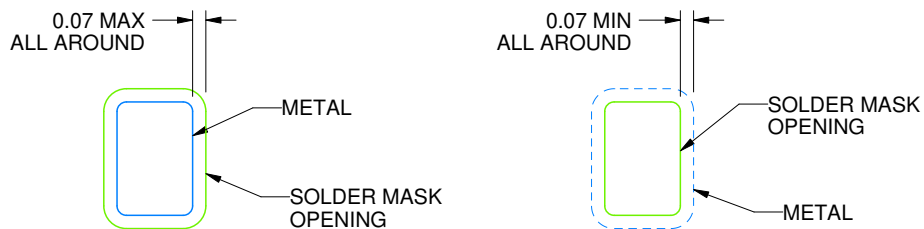

NON SOLDER MASK
DEFINED
(PREFERRED)

SOLDER MASK
DEFINED

SOLDER MASK DETAILS

4218281/C 11/2022

NOTES: (continued)

4. This package is designed to be soldered to a thermal pad on the board. For more information, see Texas Instruments literature number SLUA271 (www.ti.com/lit/sluea271).
5. Vias are optional depending on application, refer to device data sheet. If any vias are implemented, refer to their locations shown on this view. It is recommended that vias under paste be filled, plugged or tented.

EXAMPLE STENCIL DESIGN

DQC0010A

WSN - 0.8mm max height

PLASTIC SMALL OUTLINE - NO LEAD

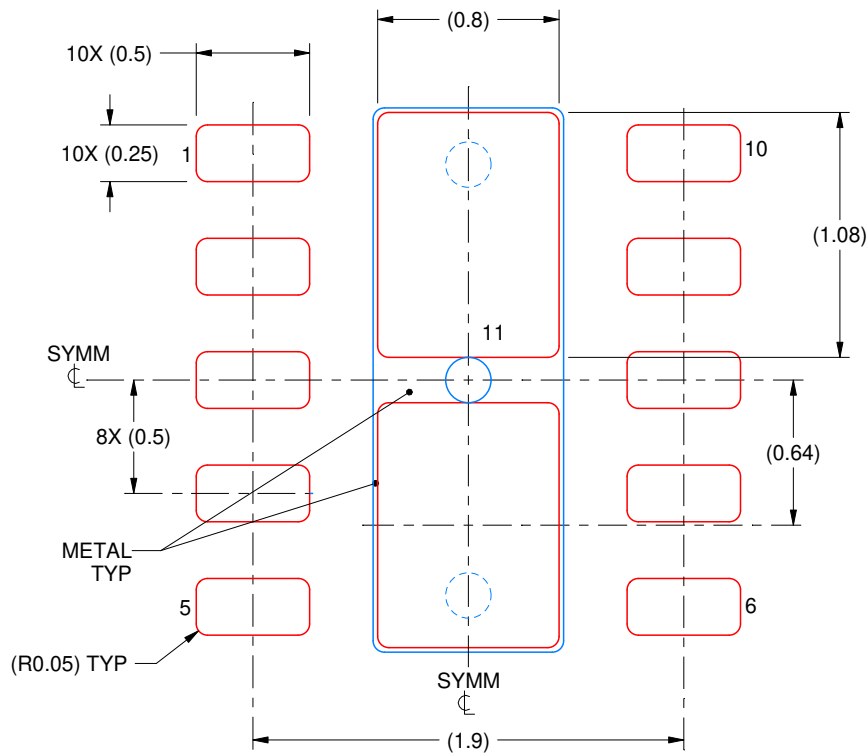

SOLDER PASTE EXAMPLE
BASED ON 0.125 mm THICK STENCIL

EXPOSED PAD 11:
86% PRINTED SOLDER COVERAGE BY AREA UNDER PACKAGE
SCALE: 30X

4218281/C 11/2022

NOTES: (continued)

6. Laser cutting apertures with trapezoidal walls and rounded corners may offer better paste release. IPC-7525 may have alternate design recommendations.

IMPORTANT NOTICE AND DISCLAIMER

TI PROVIDES TECHNICAL AND RELIABILITY DATA (INCLUDING DATA SHEETS), DESIGN RESOURCES (INCLUDING REFERENCE DESIGNS), APPLICATION OR OTHER DESIGN ADVICE, WEB TOOLS, SAFETY INFORMATION, AND OTHER RESOURCES "AS IS" AND WITH ALL FAULTS, AND DISCLAIMS ALL WARRANTIES, EXPRESS AND IMPLIED, INCLUDING WITHOUT LIMITATION ANY IMPLIED WARRANTIES OF MERCHANTABILITY, FITNESS FOR A PARTICULAR PURPOSE OR NON-INFRINGEMENT OF THIRD PARTY INTELLECTUAL PROPERTY RIGHTS.

These resources are intended for skilled developers designing with TI products. You are solely responsible for (1) selecting the appropriate TI products for your application, (2) designing, validating and testing your application, and (3) ensuring your application meets applicable standards, and any other safety, security, regulatory or other requirements.

These resources are subject to change without notice. TI grants you permission to use these resources only for development of an application that uses the TI products described in the resource. Other reproduction and display of these resources is prohibited. No license is granted to any other TI intellectual property right or to any third party intellectual property right. TI disclaims responsibility for, and you will fully indemnify TI and its representatives against, any claims, damages, costs, losses, and liabilities arising out of your use of these resources.

TI's products are provided subject to [TI's Terms of Sale](#) or other applicable terms available either on ti.com or provided in conjunction with such TI products. TI's provision of these resources does not expand or otherwise alter TI's applicable warranties or warranty disclaimers for TI products.

TI objects to and rejects any additional or different terms you may have proposed.

Mailing Address: Texas Instruments, Post Office Box 655303, Dallas, Texas 75265
Copyright © 2022, Texas Instruments Incorporated