

This document is the property of and embodies CONFIDENTIAL and PROPRIETARY information of AOR. No part of the information shown on this document may be used in any way or disclosed to others without the written consent of AOR. © 2019 AOR



REV.	ECR/ECN No.	DESCRIPTION	DRAWN/DATE	CHECKED/DATE	APPROVED/DATE
E	/	Buckle shape adjustment	May 2017-03-20	Rain 2017-03-20	Xiaohong.zhu 2017-03-20
F	/	Half gold tin changed to point gold plating	May 2017-12-27	Rain 2017-12-27	Xiaohong.zhu 2017-12-27
G	/	Increase the gilded materials issue	May 2019-01-07	Rain 2019-01-07	Xiaohong.zhu 2019-01-07

NO.	COMPONENTS	MATERIALS	SPECIFICATION:FINISH/COLOR	QTY.
1	SLIDER	GLASS FILLED LCP, UL94V-0	BLACK	1
2	HOUSING	GLASS FILLED LCP, UL94V-0	NATURE	1
3	ANCHOR-PLATE	BRASS, T=0.40±0.01mm	ALL OVER 2um MIN. MATTE TIN UNDERPLATING:1um NICKEL MIN.	2
4	CONTACT	PHOSPHOR BRONZE, T=0.15±0.01mm	CONTACT AREA SEE "NOTE" AND FOOT UNDERPLATING:1um NICKEL MIN.	N
5	MYLAR	L7.50*W5.00*H0.10	BROWN	1

NOTE:

- MATERIAL:**
HOUSING:LCP.NATURAL.UL94V-0.
COVER:LCP.BLACK.UL94-0.
CONTACT:PHOSPHOR BRONZE;T=0.15mm.
STATOR:BRASS;T=0.40mm.
- PLATING:**
CONTACT:CONTACT AREA 0.075um Au(Au Area) MIN.
PLATED UNDERPLATING:0.075um Au(Au Area) MIN.
AND FOOT UNDERPLATING:1um NICKEL MIN.
STATOR:ALL OVER 2um MIN. MATTE TIN UNDERPLATING:1um NICKEL MIN.
- COMPLIANT TO RoHS DIRECTIVE**
RoHS AND SONY SS-00259.
- PART NO. LEGEND:**

1/F F31S-1A7*1-11015
 NO. OF POSITIONS
 7H:PHOSPHOR BRONZE
 0.05um MIN Au(Au Area)
 7L:PHOSPHOR BRONZE
 G/T(Contact area 0.05um Au MIN.;Solder area 2um Sn MIN.)

文件发行
2020.09.08
Aorora

UNLESS OTHERWISE SPECIFIED TOLERANCES				ANGLE OF PROJECTION		Amphenol AORORA		
X.	±0.30	X. '	± 5'			Amphenol Aorora Technology (Huizhou) Co.,Ltd		
X.X	±0.25	X.X '	± 4'					
X.XX	±0.20	X.XX '	± 3'	DOC TYP Customer Drw		TITLE:		
X.XXX	±0.15	X.XXX '	± 2'	DRAWN DATE May.Wang 2016-08-01		0.5 PITCH FPC CONN. ZIF SMT TYPE STRAIGHT 15PIN		
LINEAR DIMS		ANGLES DIMS		DESIGN DATE May.Wang 2016-08-01		SIZE	PART NUMBER:	
DWG NO.: A-S0220				CHECKED DATE Rain.Han 2016-08-01		A4	F31S-1A7*1-11015	
MATERIAL		SEE NOTES		APPROVED DATE Hongkui.Liu 2016-08-01		SCALE	5:1	UNIT : mm
FINISHED		SEE NOTES				SHEET	1 OF 3	

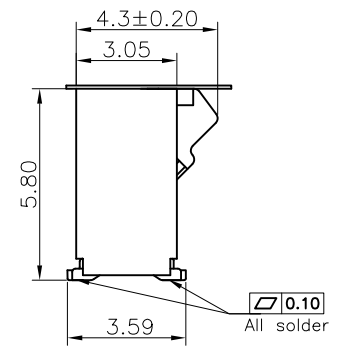
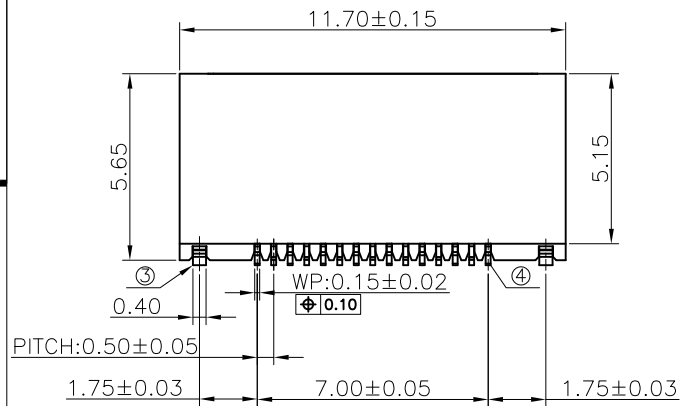
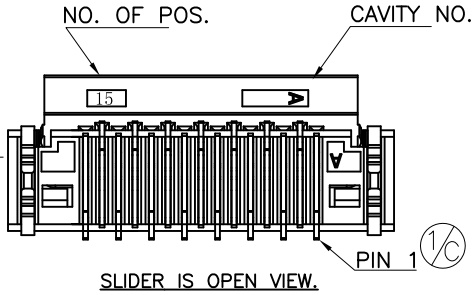
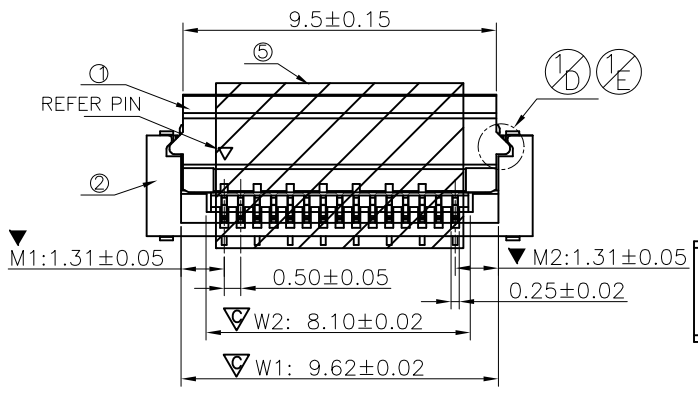

0.03 min.
The terminal height should be lower than the guide groove surface of the housing

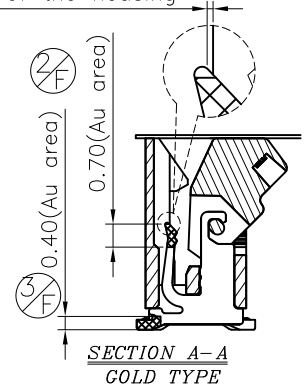
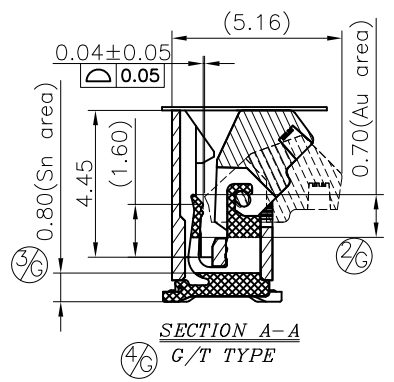

1. FFC PATTERN DIMENSION

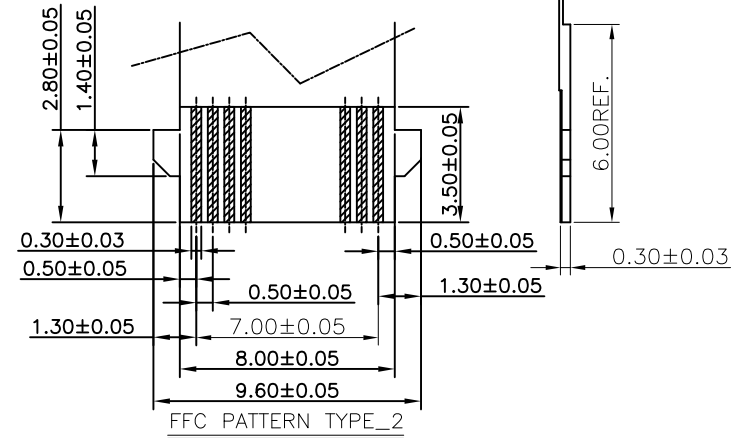
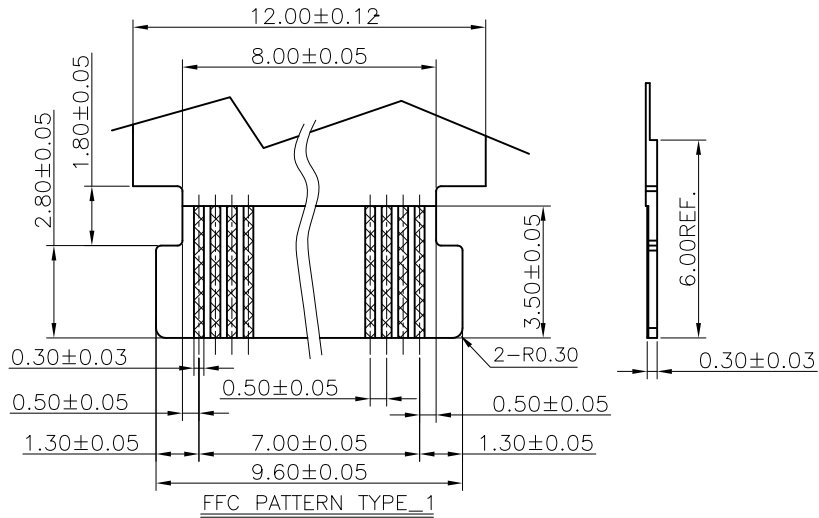

2. P.C.B LAYOUT, TOL: ±0.05

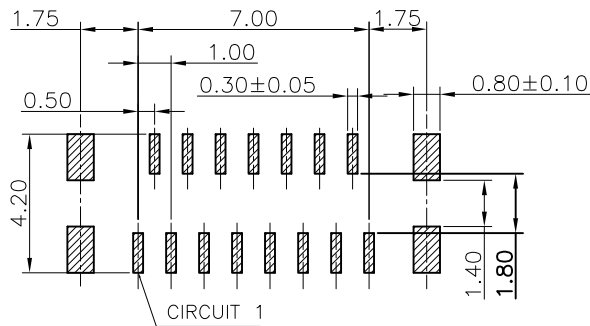

This document is the property of and embodies CONFIDENTIAL and PROPRIETARY information of AOR. No part of the information shown on this document may be used in any way or disclosed to others without the written consent of AOR. © 2019 AOR



文件发行
2020.09.08
Aorora

UNLESS OTHERWISE SPECIFIED TOLERANCES			ANGLE OF PROJECTION		 Amphenol Aorora Technology (Huizhou) Co.,Ltd				
X.	±0.30	X. °	± 5'						
X.X	±0.25	X.X °	± 4'			DOC TYP Customer Drw		TITLE:	
X.XX	±0.20	X.XX °	± 3'	DRAWN	May.Wang	0.5 PITCH FPC CONN. ZIF SMT TYPE STRAIGHT 15PIN			
X.XXX	±0.15	X.XXX °	± 2'	DATE	2016-08-01				
LINEAR DIMS			ANGLES DIMS		DESIGN	May.Wang	SIZE	PART NUMBER:	REV.
DWG NO.: A-S0220					DATE	2016-08-01	A4	F31S-1A7*1-11015	G
MATERIAL		SEE NOTES		CHECKED	Rain.Han				
FINISHED		SEE NOTES		DATE	2016-08-01	SCALE	5:1	UNIT : mm	SHEET 2 OF 3
				APPROVED	Hongkui.Liu				
				DATE	2016-08-01				

This document is the property of and embodies CONFIDENTIAL and PROPRIETARY information of AOR. No part of the information shown on this document may be used in any way or disclosed to others without the written consent of AOR. © 2019 AOR



1. PACKING INTO REEL:

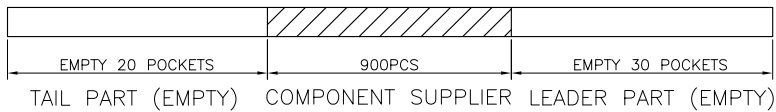
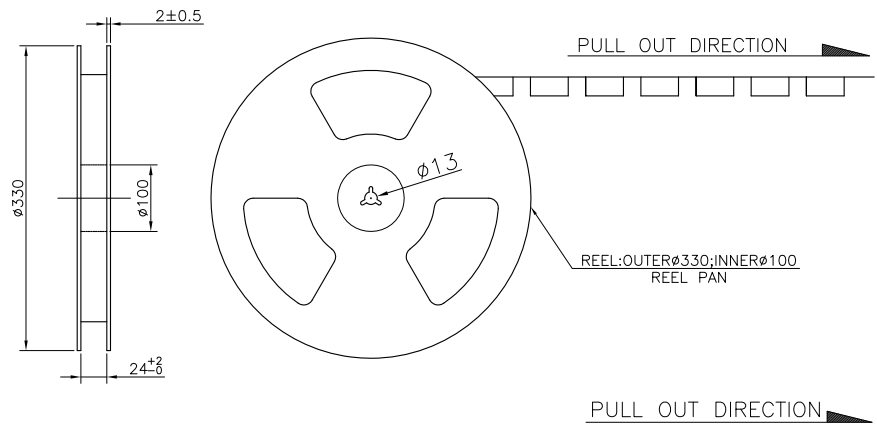
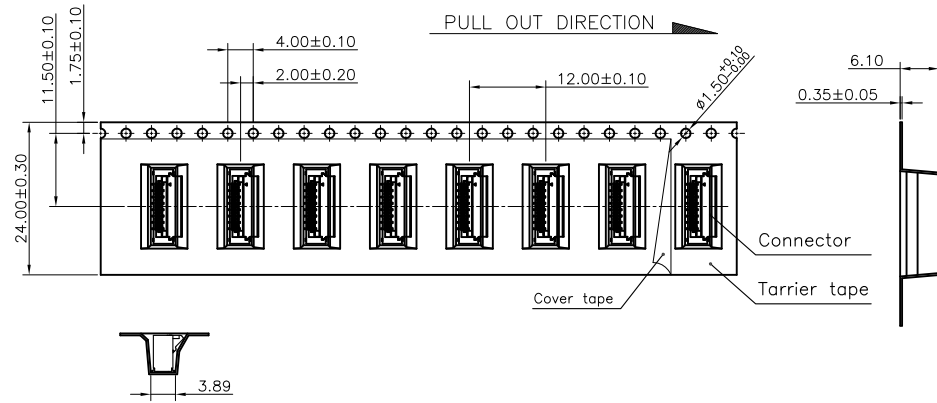

NOTES:

1. MATERIAL:
 - 1.1 CARRY TAPE:HIPS,T=0.35mm,CLEAR
 - 1.2 REEL:HIPS,BLUE.
 - 1.3 SHIM:PE,CLEAR.
2. PRIMARY PACKING:900PCS/REEL.
3. SECONDARY PACKING: 10 REELS/CARTON ("TOTAL"=9,000/CARTON).
4. PEELING RESISTANCE: 0.1N~0.7N(10~70gf);
 PEELING ANGLE: 165°~180°;
 PEELING SPEED: 300mm/minutes.

2.PACKING INTO OUTER BOX

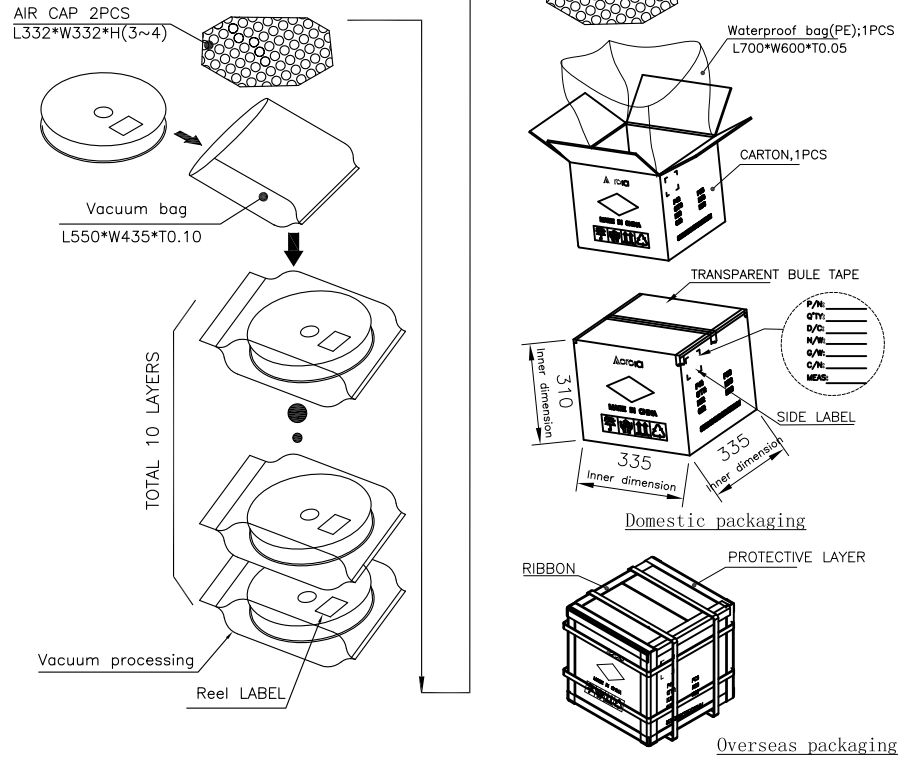

UNLESS OTHERWISE SPECIFIED TOLERANCES				ANGLE OF PROJECTION		 Amphenol Aorora Technology (Huizhou) Co.,Ltd											
X.	±0.30	X. '	± 5'			TITLE: 0.5 PITCH FPC CONN. ZIF SMT TYPE STRAIGHT 15PIN											
X.X	±0.25	X.X '	± 4'														
X.XX	±0.20	X.XX '	± 3'	DOC TYP		Customer Drw											
X.XXX	±0.15	X.XXX '	± 2'	DRAWN		DATE		May 2016-08-01		SIZE	PART NUMBER:		REV.				
LINEAR DIMS		ANGLES DIMS		DESIGN		DATE		May 2016-08-01			A4	F31S-1A7*1-11015		G			
DWG NO.: A-S0220				CHECKED		DATE		Rain.Han 2016-08-01		SCALE		1:1			UNIT : mm		SHEET 3 OF 3
MATERIAL				SEE NOTES				APPROVED		DATE		Leo.Liu 2016-08-01					
FINISHED				SEE NOTES													

