

1

2

3

4

5

6

7

A

A

B

B

C

C

D

D

E

E

F

F

G

G

H

H

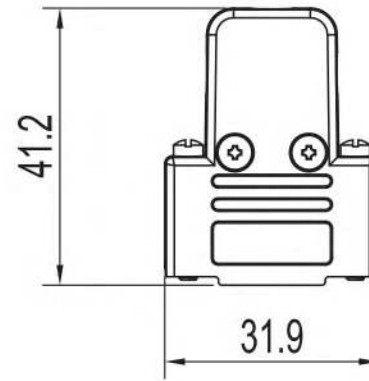
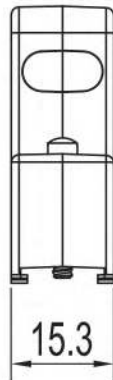
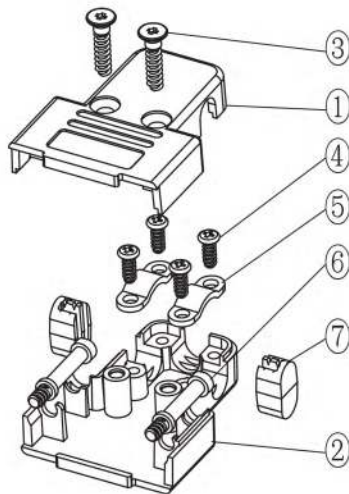

#### TECHNICAL SPECIFICATIONS

Material: ABS Plastic, UL94 V-0  
 Operating Temperature: -55°C to +110°C  
 Thumbscrews: UNC 4-40

No. of contacts: 09-15-25-37

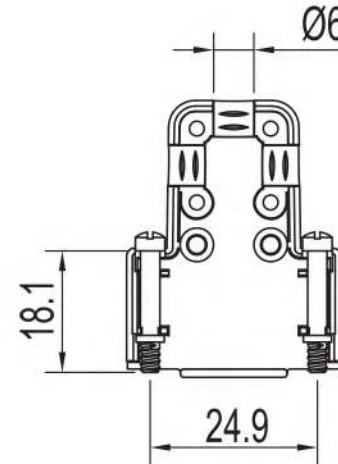

Item	QTY	Part description
1	1	Upper Half
2	1	Lower Half
3	2	ST2.9x13 Self Tapping Screw
4	4	ST2.9x6 Self Tapping Screw
5	2	Cable Clamp
6	2	Jackscrews UNC4-40 x 18.1mm
7	2	Plastic Blanker

**RoHS compliant**  
 Unit: mm

Scale	Free				Date	Name	Customer-No.	
TOLERANCE					Drawn	17.08.2017	S.Bölling	
0~6	±0.10				Approved	17.08.2017	S.Bölling	
6~30	±0.20							
30~120	±0.30							
120~400	±0.50							
DIM	Tol							
Angle	±1°	Ⓢ	Drawn	17.08.2017				S.Bölling
Angle	Tol	Id.	Modification	Date				Name

Customer-No.

Drawn

Date

Name

ASSMANN WSW-No.

ACOV-SUB-09NB21

Drawing-No.

ASS\_5262\_CO

rev00

Replace

Sheet 1/4

1

2

3

4

5

6

7

SV4382

1

2

3

4

5

6

7

A

A

B

B

C

C

D

D

E

E

F

F

G

G

H

H

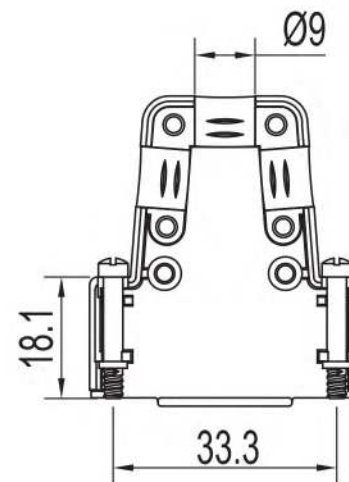
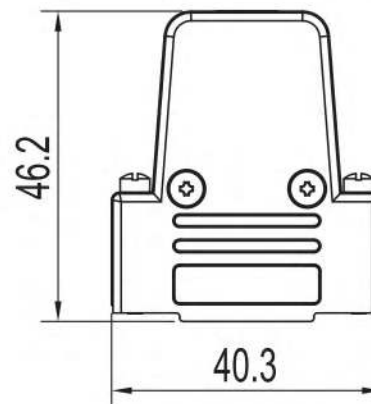
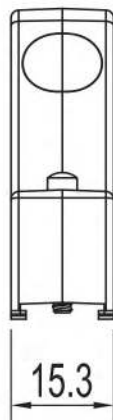
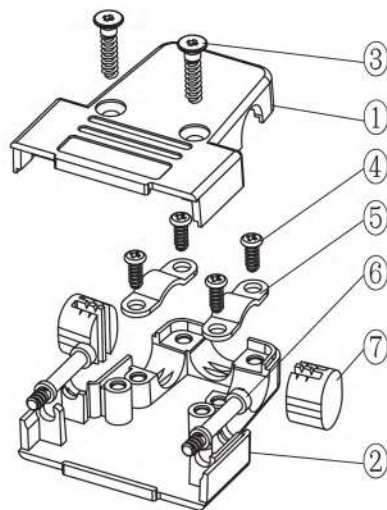

### TECHNICAL SPECIFICATIONS

Material: ABS Plastic, UL94 V-0  
 Operating Temperature: -55°C to +110°C  
 Thumbscrews: UNC 4-40

No. of contacts: 09-15-25-37

Item	QTY	Part description
1	1	Upper Half
2	1	Lower Half
3	2	ST2.9x13 Self Tapping Screw
4	4	ST2.9x6 Self Tapping Screw
5	2	Cable Clamp
6	2	Jackscrews UNC4-40 x 18.1mm
7	2	Plastic Blanker

**RoHS compliant**  
 Unit: mm

Scale	Free				Date	Name	Customer-No.	
TOLERANCE					Drawn	17.08.2017	S.Bölling	
0~6	±0.10				Approved	17.08.2017	S.Bölling	
6~30	±0.20							
30~120	±0.30							
120~400	±0.50							
DIM	Tol							
Angle	±1°	Ⓢ	Drawn	17.08.2017				S.Bölling
Angle	Tol	Id.	Modification	Date				Name

ASSMANN WSW-No.  
**ACOV-SUB-15NB21**

Drawing-No.  
**ASS\_5262\_CO** rev00  
 Replace Sheet 2/4

1

2

3

4

5

6

7

SV4382

1

2

3

4

5

6

7

A

A

B

B

C

C

D

D

E

E

F

F

G

G

H

H

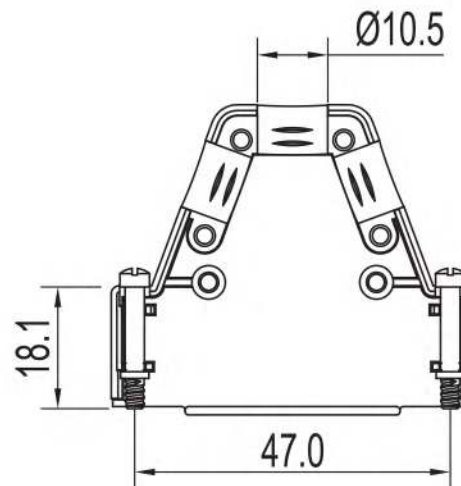
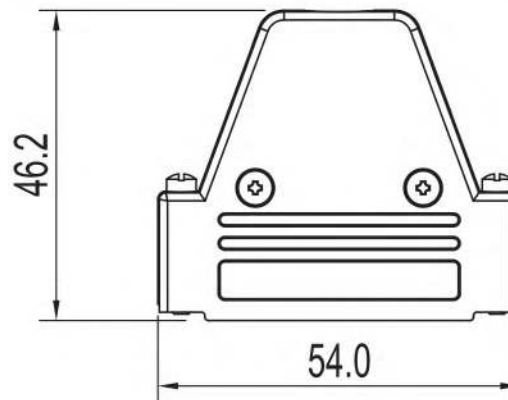
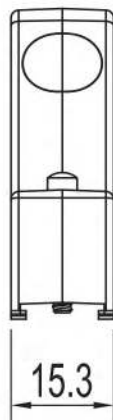
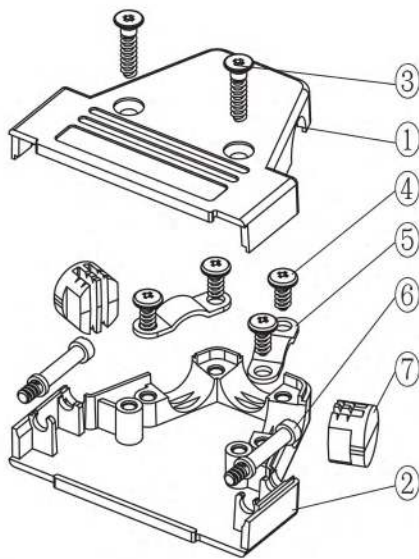

### TECHNICAL SPECIFICATIONS

Material: ABS Plastic, UL94 V-0  
 Operating Temperature: -55°C to +110°C  
 Thumbscrews: UNC 4-40

No. of contacts: 09-15-25-37

Item	QTY	Part description
1	1	Upper Half
2	1	Lower Half
3	2	ST2.9x13 Self Tapping Screw
4	4	ST2.9x6 Self Tapping Screw
5	2	Cable Clamp
6	2	Jackscrews UNC4-40 x 18.1mm
7	2	Plastic Blanker

**RoHS compliant**  
 Unit: mm

Scale	Free				Date	Name	Customer-No.	
TOLERANCE					Drawn	17.08.2017	S.Bölling	
0~6	±0.10				Approved	17.08.2017	S.Bölling	
6~30	±0.20							
30~120	±0.30							
120~400	±0.50							
DIM	Tol							
Angle	±1°	©	Drawn	17.08.2017				S.Bölling
Angle	Tol	Id.	Modification	Date				Name

ASSMANN WSW-No.  
**ACOV-SUB-25NB21**

Drawing-No.  
**ASS\_5262\_CO** rev00  
 Replace Sheet 3/4

1

2

3

4

5

6

7

SV4382

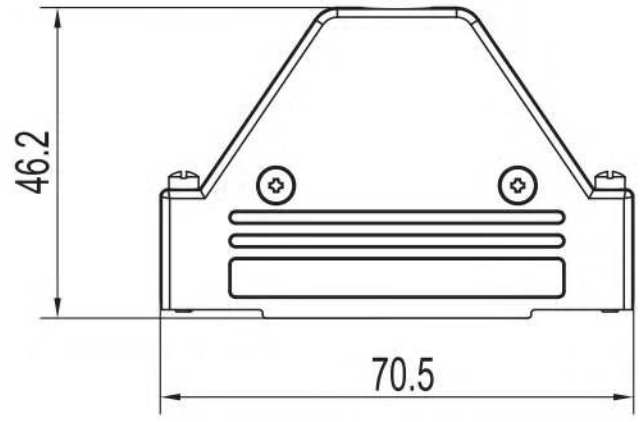
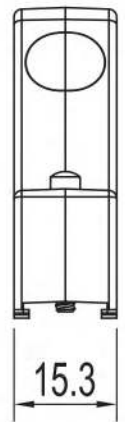

**TECHNICAL SPECIFICATIONS**

Material: ABS Plastic, UL94 V-0  
 Operating Temperature: -55°C to +110°C  
 Thumbscrews: UNC 4-40

No. of contacts: 09-15-25-37

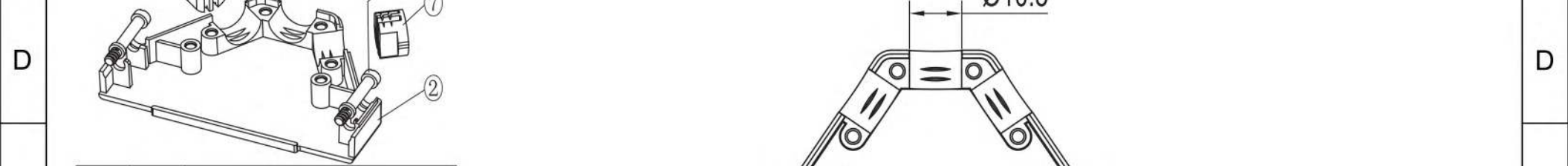
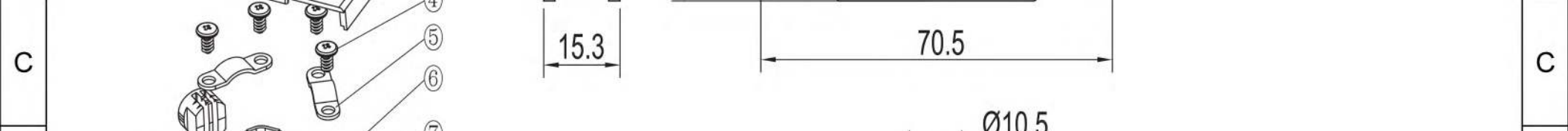

Item	QTY	Part description
1	1	Upper Half
2	1	Lower Half
3	2	ST2.9x13 Self Tapping Screw
4	4	ST2.9x6 Self Tapping Screw
5	2	Cable Clamp
6	2	Jackscrews UNC4-40 x 18.1mm
7	2	Plastic Blanker

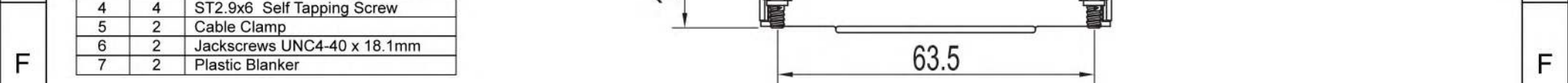

**RoHS compliant**  
 Unit: mm

Scale	Free				Date	Name	Customer-No.	
TOLERANCE					Drawn	17.08.2017	S.Bölling	
0~6	±0.10				Approved	17.08.2017	S.Bölling	
6~30	±0.20							
30~120	±0.30							
120~400	±0.50							
DIM	Tol							
Angle	±1°	Ⓢ	Drawn	17.08.2017				S.Bölling
Angle	Tol	Id.	Modification	Date				Name

Customer-No.  
 ASSMANN WSW-No.  
**ACOV-SUB-37NB21**

Drawing-No.  
**ASS\_5262\_CO** rev00  
 Replace Sheet 4/4