



FocusLCDs.com  
LCDs MADE SIMPLE®

Ph. 480-503-4295 | [NOPP@FocusLCD.com](mailto:NOPP@FocusLCD.com)

TFT | CHARACTER | UWVD | FSC | SEGMENT | CUSTOM | REPLACEMENT

## TFT Display Module

Part Number

E70RA1-HW520-C

### Overview:

- 7.0-inch TFT: 164.6x99.6mm
- 1024x600 pixels
- HDMI Interface
- Micro-USB CTP Interface
- White LED back-light
- Transmissive
- Capacitive Touch Panel
- 520 NITS
- Controller: EK73215+EK79001
- RoHS Compliant

## Description

This is a color active matrix TFT (Thin Film Transistor) LCD (Liquid Crystal Display) that uses amorphous silicon TFT as a switching device. This model is composed of a transmissive type TFT-LCD Panel, driver circuit, capacitive touch panel and a backlight unit. The resolution of the 7.0" TFT-LCD contains 1024(RGB)x600 pixels.

## TFT Features

Low Input Voltage: 3.3V

TFT Interface: HDMI

Display Colors: 16.7M colors

General Information Items	Specification	Unit	Note
	Main Panel		
TFT Display area (AA)	154.21 (H) x 85.92 (V) (7.0 inch)	mm	-
Driver element	TFT active matrix	-	-
Display Colors	16.7M	colors	-
Number of pixels	1024(RGB)x600	dots	-
TFT Pixel arrangement	RGB vertical stripe	-	-
Pixel pitch	0.1506 (H) x 0.1432 (V)	mm	-
Viewing angle	ALL	o'clock	-
TFT Controller IC	EK73215+EK79001	-	-
LCM Luminance	500 nits (TYP)	-	-
Video Input	HDMI	-	-
Operating temperature	-20~+70	°C	-
Storage temperature	-20~+70	°C	-

## Mechanical Information

Item		Min	Typ.	Max	Unit	Note
Module size	Height (H)		164.6		mm	-
	Vertical (V)		99.6		mm	-
	Depth (D)		11.73		mm	-

## 2. Outline Dimensions

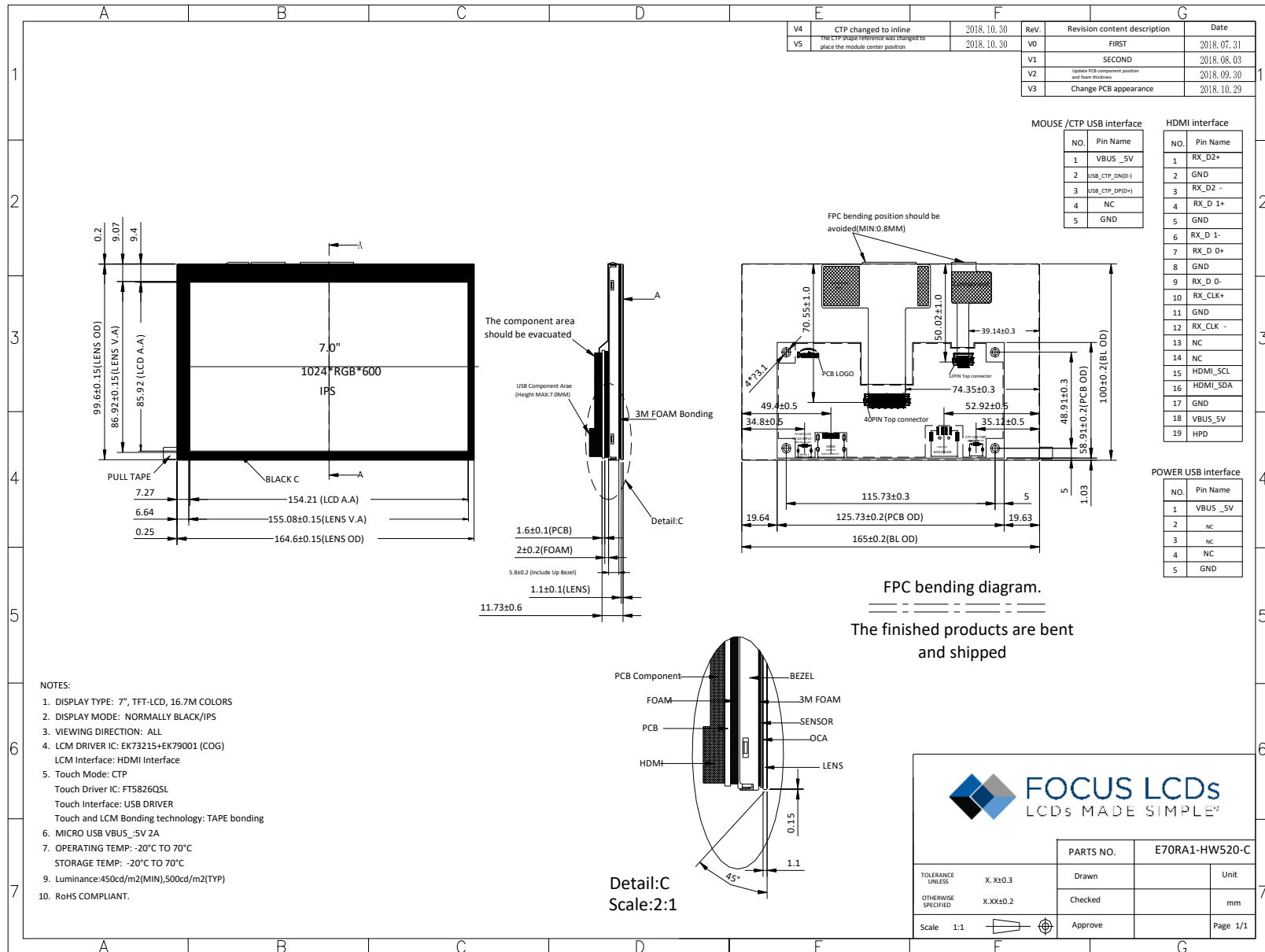

### 3. Input Terminal Pin Assignment

#### 3.1 HDMI Pin Connection

NO	SYMBOL	Description	I/O
1	RX_D2+	HDMI receiver channel 2 positive analog input	I
2	GND	Ground	P
3	RX_D2-	HDMI receiver channel 2 negative analog input	I
4	RX_D1+	HDMI receiver channel 1 positive analog input	I
5	GND	Ground	P
6	RX_D1-	HDMI receiver channel 1 negative analog input	I
7	RX_D0+	HDMI receiver channel 0 positive analog input	I
8	GND	Ground	P
9	RX_D0-	HDMI receiver channel 0 negative analog input	I
10	RX_CLK+	HDMI receiver clock positive analog input	I
11	GND	Ground	P
12	RX_CLK-	HDMI receiver clock negative analog input	I
13	NC	Not connected	
14	NC	Not connected	
15	HDMI_SCL	HDMI receiver DDC data channel	I/O
16	HDMI_SDA	HDMI receiver DDC clock channel	I
17	GND	Ground	P
18	VBUS_5V	HDMI supply voltage 5.0V	P
19	HPD	HDMI receiver hot plug detect output	O

#### 3.2 Micro1 USB Power Pin Definition

NO	SYMBOL	Description	I/O
1	VBUS_5V	LCM supply voltage (5.0V, 2A)	P
2	NC	Not connected	
3	NC	Not connected	
4	NC	Not connected	
5	GND	Ground	P

#### 3.3 Micro 2 USB CTP Pin Definition

NO	SYMBOL	Description	I/O
1	VBUS_5V	CTP supply voltage (5.0V)	
2	USB_CTP_DN(D-)	USB data positive analog input	
3	USB_CTP_DP(D+)	USB data negative analog input	
4	NC	I2C clock input	
5	GND	Ground	

## 4. LCD Optical Characteristics

### 4.1 Optical Specifications

Item	Symbol	Condition	Min	Typ.	Max	Unit	Note
Uniformity	U%		80	--	--	%	(3)
Contrast Ratio	CR		600	800	--	%	(2)
Response Time	Rising	TR+TF	--	25	40	ms	(4)
	Falling						
Color Filter Chromaticity	White	WX	θ=0 Normal viewing angle	0.2668	0.3068	0.3486	(5)(6)
		WY		0.2984	0.3384	0.3784	
	Red	RX		0.5653	0.6053	0.6453	
		RY		0.3145	0.3545	0.3945	
	Green	GX		0.2686	0.3086	0.3486	
		GY		0.5272	0.5672	0.6072	
	Blue	BX		0.1120	0.1520	0.1920	
		BY		0.0509	0.0909	0.1131	
Viewing Angle	Hor.	ΘL	CR≥10	--	85	--	degree
		ΘR		--	85	--	
	Ver.	ΘT		--	85	--	
		ΘB		--	85	--	
Option View Direction			ALL				(1)

### Optical Specification Reference Notes:

(1) Definition of Viewing Angle: The viewing angle is the angle at which the contrast ratio is greater than 10. The viewing angles are determined for the horizontal or 3,9 o'clock direction and the vertical or 6,12 o'clock direction with respect to the optical axis which is normal to the LCD surface.

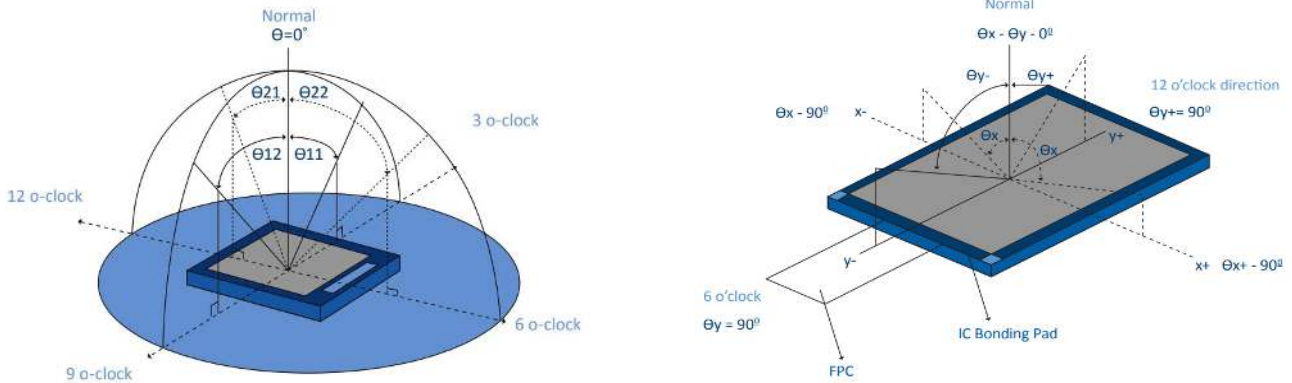

(2) Definition of Contrast Ratio (Cr): measured at the center point of panel. The contrast ratio (Cr) measured on a module, is the ratio between the luminance (Lw) in a full white area (R=G=B=1) and the luminance (Ld) in a dark area (R=G=B=0).

$$Cr = \frac{Lw}{Ld}$$

(3) Definition of transmittance (T%): The transmittance of the panel including the polarizers is measured with electrical driving. The equation for transmittance Tr is:

$$Tr = \frac{It}{Io} \times 100\%$$

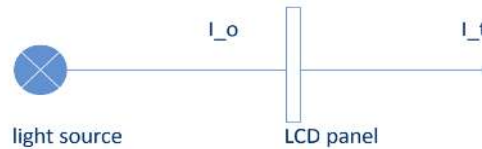

Io = the brightness of the light source.  
 It = the brightness after panel transmission

(4) Definition of Response Time (Tr, Tf): The rise time 'Tr' is defined as the time for luminance to change from 90% to 10% as a result of a change of the electrical condition. The fall time 'Tf' is defined as the time for luminance to change from 10% to 90% as a result of a change of the electrical condition.

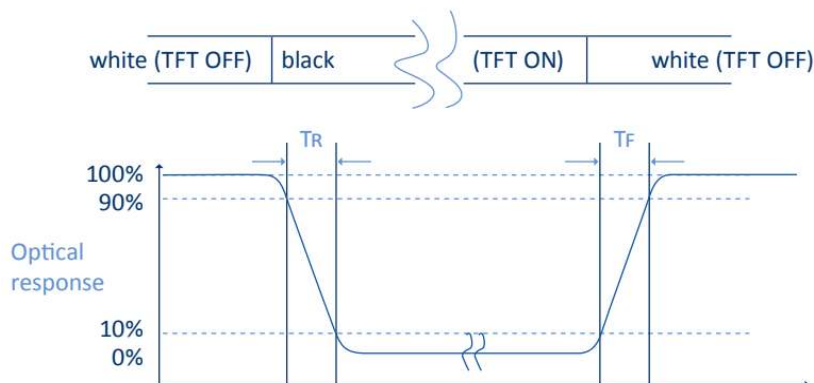

(5) Definition of Color Gamut:

Measuring machine CFT-01. NTSC's Primaries:  $R(x,y,Y), G(x,y,Y), B(x,y,Y)$ . FPM520 of Westar Display Technologies, INC., which utilized SR-3 for Chromaticity and BM-5A for other optical characteristics. The color chromaticity shall be calculated from the spectral data measured with all pixels first in red, green, blue and white. Measurements shall be made at the center of the panel.

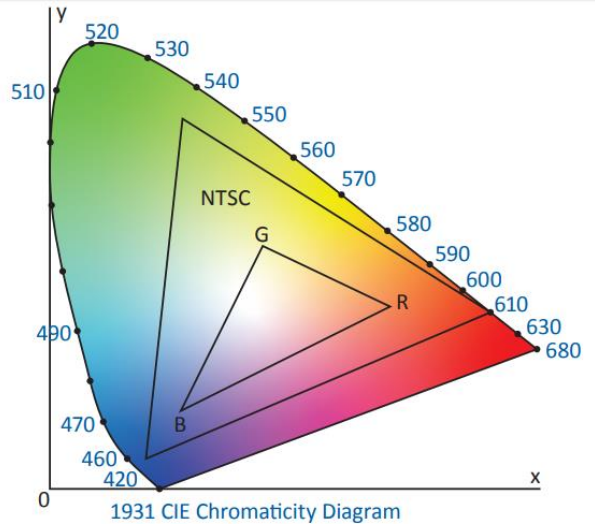
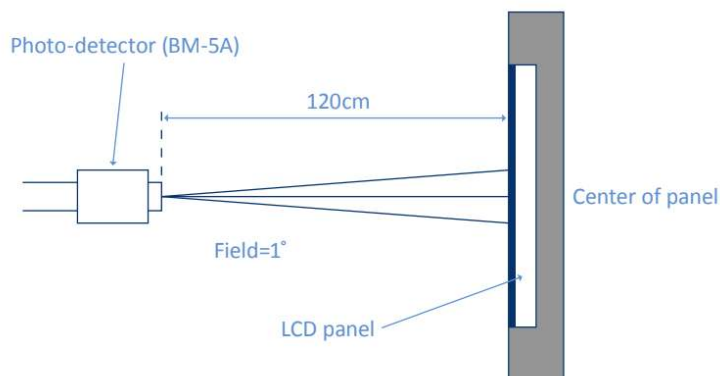
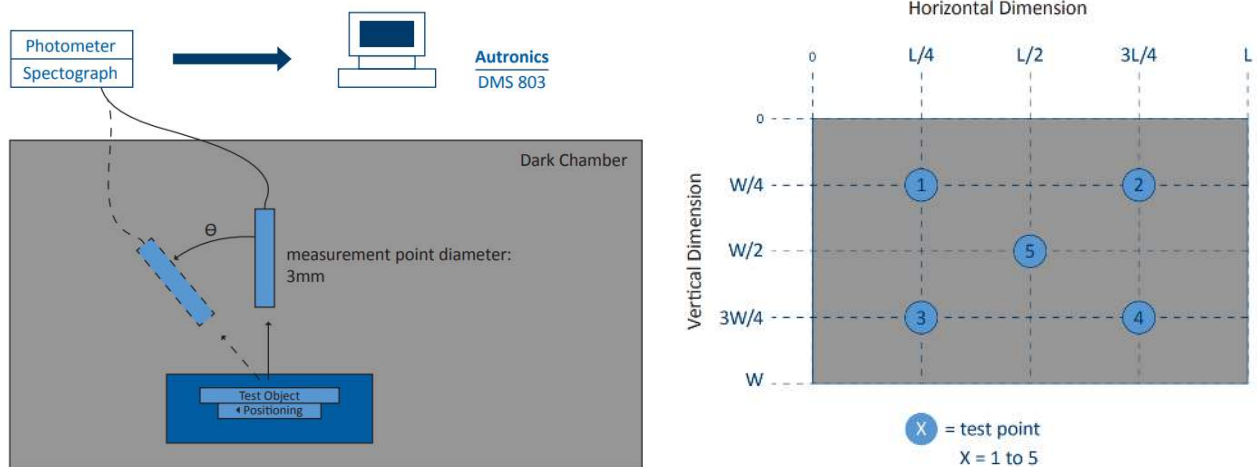

Fig. 1931 CIE chromacity diagram

$$\text{Color gamut: } S = \frac{\text{Area of RGB triangle}}{\text{Area of NTSC triangle}} \times 100\%$$

(6) Definition of Optical Measurement Setup:

The LCD module should be stabilized at a given temperature for 20 minutes to avoid abrupt temperature change during measuring. In order to stabilize the luminance, the measurement should be executed after lighting backlight for 20 minutes.



## 5. TFT Electrical Characteristics

### 5.1 Absolute Maximum Rating (Ta=25 °C, VSS=0V)

Characteristics	Symbol	Min	Max	Unit
LCM Supply Voltage	VDD1	-0.3	5.5	V
CTP Supply Voltage	VDD2	-0.3	5.5	V
Operating Temperature	TOP	-20	+70	°C
Storage Temperature	TST	-30	+80	°C

*NOTE: If the absolute maximum rating of the above parameters is exceeded, even momentarily, the quality of the product may be degraded. Absolute maximum ratings specify the values which the product may be physically damaged if exceeded. Be sure to use the product within the range of the absolute maximum ratings.*

### 5.2 DC Electrical Characteristics

Characteristics	Symbol	Min	Typ.	Max	Unit	Note
LCM Supply Voltage	VDD1	4.8	5.0	5.2	V	Micro1
CTP Supply Voltage	VDD2	4.8	5.0	5.2	V	Micro2
LCM Normal Mode Current	IDD1	--	850	--	mA	
CTP Normal Mode Current	IDD2	--	20	--	mA	



## 6. TFT AC Characteristics

### 6.1 Interface Timing

Parameter	Symbol	Min	Typ.	Max	Unit	Note
DCLK Frequency	fclk	40.8	51.2	67.2	MHz	Frame Rate = 60Hz
Horizontal Display Area	thd	1024			DCLK	
HSYNC Period Time	th	1144	1344	1400	DCLK	
HSYNC Blanking	thb+thp	90	320	376	DCLK	
Vertical Display Area	tvd	600			H	
VSYNC Period Time	tv	610	635	800	H	
VSYNC Blanking	tvb+tvfp	10	35	200	H	

## 7. Cautions and Handling Precautions

### 7.1 Handling and Operating the Module

1. When the module is assembled, it should be attached to the system firmly. Do not warp or twist the module during assembly work.
2. Protect the module from physical shock or any force. In addition to damage, this may cause improper operation or damage to the module and back-light unit.
3. Note that polarizer is very fragile and could be easily damaged. Do not press or scratch the surface.
4. Do not allow drops of water or chemicals to remain on the display surface. If you have the droplets for a long time, staining and discoloration may occur.
5. If the surface of the polarizer is dirty, clean it using some absorbent cotton or soft cloth.
6. The desirable cleaners are water, IPA (Isopropyl Alcohol) or Hexane. Do not use ketene type materials (ex. Acetone), Ethyl alcohol, Toluene, Ethyl acid or Methyl chloride. It might permanent damage to the polarizer due to chemical reaction.
7. If the liquid crystal material leaks from the panel, it should be kept away from the eyes or mouth. In case of contact with hands, legs, or clothes, it must be washed away thoroughly with soap.
8. Protect the module from static; it may cause damage to the CMOS ICs.
9. Use fingerstalls with soft gloves in order to keep display clean during the incoming inspection and assembly process.
10. Do not disassemble the module.
11. Protection film for polarizer on the module shall be slowly peeled off just before use so that the electrostatic charge can be minimized.
12. Pins of I/F connector shall not be touched directly with bare hands.
13. Do not connect, disconnect the module in the "Power ON" condition.
14. Power supply should always be turned on/off by the item Power On Sequence & Power Off Sequence.

### 7.2 Storage and Transportation

1. Do not leave the panel in high temperature, and high humidity for a long time. It is highly recommended to store the module with temperature from 0 to 35 °C and relative humidity of less than 70%
2. Do not store the TFT-LCD module in direct sunlight.
3. The module shall be stored in a dark place. When storing the modules for a long time, be sure to adopt effective measures for protecting the modules from strong ultraviolet radiation, sunlight, or fluorescent light.
4. It is recommended that the modules should be stored under a condition where no condensation is allowed. Formation of dewdrops may cause an abnormal operation or a failure of the module. In particular, the greatest possible care should be taken to prevent any module from being operated where condensation has occurred inside.
5. This panel has its circuitry FPC on the bottom side and should be handled carefully in order not to be stressed.