

2 x 4" 150W AC-DC Power Supplies

<https://product.tdk.com/en/power/cus-m>
www.emea.lambda.tdk.com/cus150m



The compact CUS150M is packaged in the industry standard 2x4" footprint. The series can deliver 150W with forced air in ambient temperatures of up to 50°C or 120W convection cooled at 40°C. Conduction cooled, the CUS150M can deliver 150W at 50°C, 100W at 70°C and 50W at 80°C. With Medical & ITE certifications, the unit can be used in both Class I & Class II (no ground wire) applications, and meets Class B Conducted and Radiated EMI. Enclosure options include baseplate, U channel, cover or top fan construction.

Features	Benefits
• Up to 150W Utilizing Convection or Conduction Cooling	• Quiet Operation
• Operation in Ambient Temperatures of up to 85°C	• Suitable for High Ambient Temperature Environments
• Medical Certifications (2 x MOPP)	• Suitable for B and BF Type Medical Equipment
• Class B Conducted and Radiated EMI	• Easier System EMC Compliance
• Suitable for Class I and Class II installations	• Flexible Utilisation
• Compact 2 x 4 x 1.24" Size	• Space Saving in End Equipment
• Enclosure & Cooling Options	• Versatile Application

Model Selector							
Model	Nominal Output Voltage (V)	Factory Set ⁽¹⁾ Output Voltage Capability (V)	Fan Supply (V)	Maximum Current Convection (A) ⁽²⁾	Maximum Current Forced Air (A)	Maximum Power Convection (W) ⁽²⁾	Maximum Power Forced Air (W)
CUS150M-12 or /B	12	12 - 13.2	11.6	10	12.5	120	150
CUS150M-12/A or /U	12	12 - 13.2	11.6	12.5	12.5	150	150
CUS150M-12/F	12	-	11.6	12.5	Internal fan	150	Internal fan
CUS150M-15 or /B	15	15 - 16.5	9.8	8	10	120	150
CUS150M-15/A or /U	15	15 - 16.5	9.8	10	10	150	150
CUS150M-15/F	15	-	9.8	10	Internal fan	150	Internal fan
CUS150M-18 or /B	18	18 - 19.8	11.6	6.66	8.33	120	150
CUS150M-18/A or /U	18	18 - 19.8	11.6	8.33	8.33	150	150
CUS150M-18/F	18	-	11.6	8.33	Internal fan	150	Internal fan
CUS150M-24 or /B	24	24 - 26.4	11.6	5	6.25	120	150
CUS150M-24/A or /U	24	24 - 26.4	11.6	6.25	6.25	150	150
CUS150M-24/F	24	-	11.6	6.25	Internal fan	150	Internal fan
CUS150M-28 or /B	28	28 - 30.8	10.8	4.28	5.35	120	150
CUS150M-28/A or /U	28	28 - 30.8	10.8	5.35	5.35	150	150
CUS150M-28/F	28	-	10.8	5.35	Internal fan	150	Internal fan
CUS150M-36 or /B	36	36 - 39.6	11.6	3.33	4.16	120	150
CUS150M-36/A or /U	36	36 - 39.6	11.6	4.16	4.16	150	150
CUS150M-36/F	36	-	11.6	4.16	Internal fan	150	Internal fan
CUS150M-48 or /B	48	48 - 50	11.6	2.5	3.12	120	150
CUS150M-48/A or /U	48	48 - 50	11.6	3.12	3.12	150	150
CUS150M-48/F	48	-	11.6	3.12	Internal fan	150	Internal fan

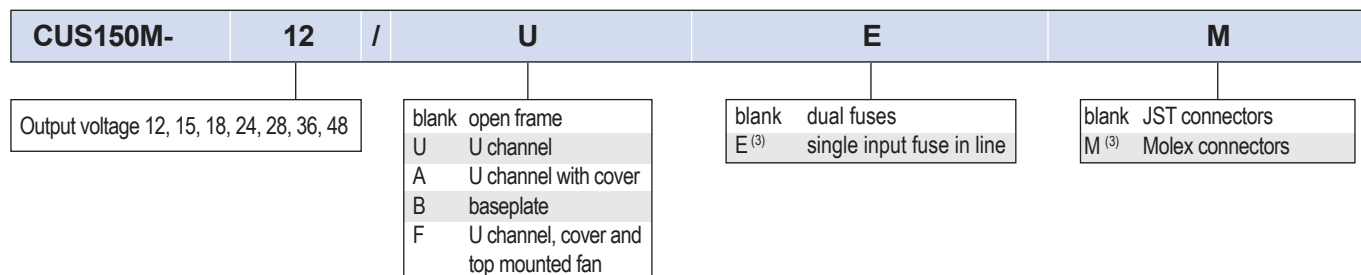

Examples: CUS150M-24/UE CUS150M-12V5/A.

Specifications		
Model	CUS150M	
Input		
Input Voltage range	Vac	85 - 264 ⁽⁴⁾
Input Frequency	Hz	47 - 63 ⁽⁵⁾
Input Current (100Vac)	A	2.2
Inrush Current at 230Vac (Cold Start)	A	<65
Leakage Current	uA	<250 at 230Vac 63Hz
Touch Current (Enclosure Leakage)	uA	<100
Power Factor (115/230Vac)	-	>0.98 / 0.92 (100% load)
Harmonic Compliance	-	Meets IEC61000-3-2 Class A, Class C >120W output
No Load Power Consumption	W	<0.5 (230Vac)
Hold Up Time	ms	>18
Efficiency	%	Up to 94
Average Efficiency	%	>91 Measured at 25%, 50%, 75% and 100% load conditions
Conducted & Radiated EMI	-	EN55032/EN55011-B (See application notes for conditions)
Immunity	-	Compliant with EN60601-1-2:2015 (Ed4), see immunity table
Insulation Class	-	Construction suitable for Class I or Class II installation
Safety Certifications and Markings	-	IEC/EN/UL/CSA62368-1, 60950-1, IEC/EN60601-1, ES60601-1, CE Mark and UKCA Mark Designed to meet IEC61010-1 and EN60335-1 compliant versions are available ⁽³⁾

Immunity				
Test	Standard	Test Level	Criteria	Notes (the power stated below is total power (main power + fan output))
ESD	EN61000-4-2	4	A	-
Radiated Susceptibility	EN61000-4-3	3	A	Includes proximity field requirements of EN60601-1-2:2015
Electrical Fast Transient Burst	EN61000-4-4	4	A	(AC Port, 5kHz and 100kHz)
Surge	EN61000-4-5	3	A	-
Conducted Susceptibility	EN61000-4-6	3	A	-
Magnetic fields	EN61000-4-8	4	A	-
Voltage Dips and Input Interruptions	EN61000-4-11 Class 3 Industrial, incl EN55024 (100Vac)	0% for 1/2 cycle	A	-
		0% for 1 cycle	A/B	A up to 125W, B above 125W
		40% for 10/12 cycles	B	-
		70% for 25/30 cycles	A	-
		80% for 250/300 cycles	A	-
		0% for 250/300 cycles	B	-
	EN61000-4-11 Class 3 Industrial, incl EN55024 (240Vac)	0% for 1/2 cycle	A	-
		0% for 1 cycle	A/B	A up to 125W, B above 125W
		40% for 10/12 cycles	A/B	A up to 120W, B above 120W
		70% for 25/30 cycles	A	-
		80% for 250/300 cycles	A	-
		0% for 250/300 cycles	B	-
	EN60601-1-2:2015 (100Vac)	0% for 1/2 cycle	A	-
		0% for 1 cycle	A/B	A up to 125W, B above 125W
		70% for 25/30 cycles	A	-
		0% for 250/300 cycles	B	-
EN60601-1-2:2015 (240Vac)	0% for 1/2 cycle	A	-	
	0% for 1 cycle	A/B	A up to 125W, B above 125W	
	70% for 25/30 cycles	A	-	
	0% for 250/300 cycles	B	-	
Ringwave Test	EN61000-4-12	3	A	-
Voltage Fluctuations	EN61000-4-14	Class 3	A	-
SEMI F47 Line Dip	SEMI F47	-	-	Consult factory

Specifications		
Model		CUS150M
Output		
Line Regulation	%	≤0.5 (90 - 264VAC)
Load Regulation	%	≤1 (0 - 100% load)
Ripple & Noise	%	<1 of nominal output for operating temperatures above 0°C At -20°C: 12V model <4, 15V & 18V model <3, other models <2
Temperature Coefficient	%/°C	±0.02
Minimum Load	-	No minimum load required
Overcurrent Protection	%	110 to 170. Hiccup mode, automatic recovery
Overvoltage Protection	-	115-140% of standard output voltage for each model, 48V model max 60V. Latching (unit shutdown), cycle AC input to reset
Remote Sense	-	None
Fan Supply	-	10 - 12V (see model selector), 0.5A, +14/-6% regulation
Parallel Operation	-	Not possible
Series Operation	-	Please contact Technical Sales for guidance
Environmental		
Operating Temperature (-25°C start-up)	°C	-20 to +85 (70 maximum for fan version /F), see derating curves below
Storage Temperature	°C	-40 to +85 (70 maximum for fan version /F)
Operating Humidity (non condensing)	%RH	5 - 95 (15 - 90 for /F fan version)
Cooling	-	Convection, conduction or forced air cooling. See derating curves below
Altitude	m	5,000
Withstand Voltage (For 1 minute)	Vac	Input to Ground 1,500 (1xMOPP), Input to Output 4,000 (2xMOPP), Output to Ground 1,500 (1xMOPP)
Isolation Resistance	MΩ	>100 at 25°C, 70%RH & 500VDC
Vibration (non operating)	-	2G, 10-500Hz for 1 hour
Shock (non operating)	-	30G, 11ms half sine
Other		
Weight	g	Open frame: 185, /A: 260, /B: 225, /F: 270, /U: 245
Size (WxLxH)	mm	Open frame version: 50.8 x 101.6 x 31.5
Size (WxLxH)	Inches	Open frame version: 2 x 4 x 1.24
Connectors	-	Input: JST B2P3-VH, Output: JST B6P-VH, Fan: Molex 22-04-1021
Warranty	yrs	5

Notes:

See website for detailed specifications, test methods and installation manual.

Specification parameters apply at 25°C ambient temperature unless otherwise stated.

(1) Output voltage is factory set and not user adjustable. Not applicable for /F (internal fan) version.

Non-standard output versions may be subject to minimum order quantities and variations to specification. For all non-standard output voltage settings please consult Sales.

(2) Please see curves below for ambient temperature ratings.

(3) Subject to Minimum Order Quantities. Please contact Sales

(4) Derate linearly to 90% load from 90 to 85VAC input.

(5) For operation at 440Hz please consult Technical Sales.

Outline Drawing CUS150M Open Frame Unit

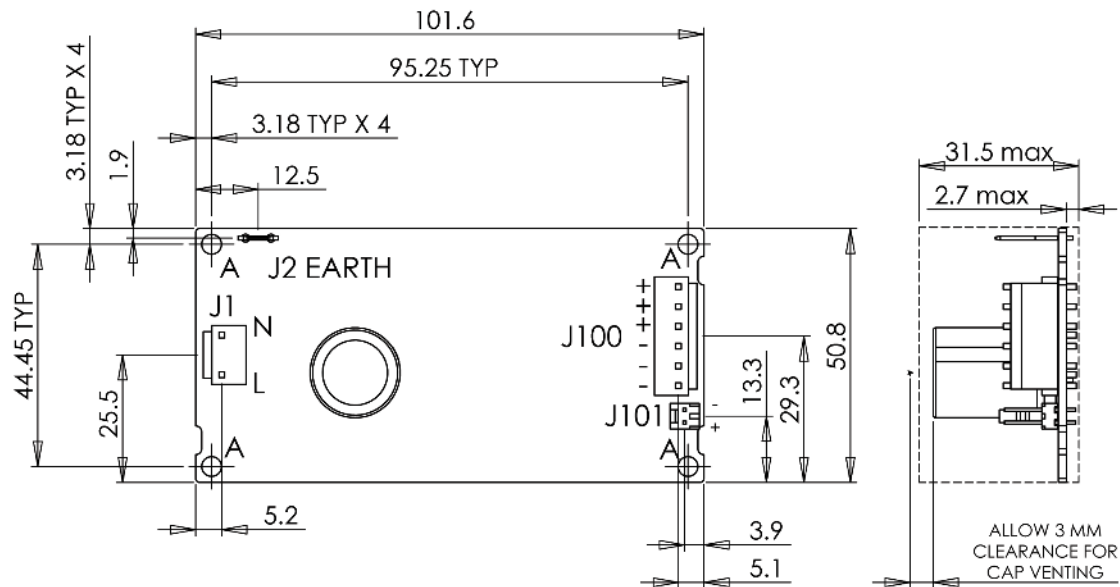

OPEN FRAME UNIT

DIMENSION TOLERANCES: 0.00 ±0.2 0.0 ±0.4
 (CONNECTOR PART NUMBERS ALSO IN APPLICATION NOTE)

REF DES	MANUFACTURER	CONNECTOR TYPE	MATING HOUSING	CRIMP
J1	JST	B2P3-VH	VAR-2	20-18AWG - SVA-41T-P1.1
J1 M-option	Molex	10-63-4027	09-50-1031	08-70-1031
J2	Tyco	62490	22-18AWG - 2-520407-2 16-14AWG - 3-520408-2	22-18AWG - 2-520407-2 16-14AWG - 2-520408-2
J100	JST	B6P-VH	VHR-6N	22-18AWG - SVH-21T-P1.1 20-16AWG - SVH-41T-P1.1
J100 M-option	Molex	09-65-2068	09-50-1061	08-70-1031
J101	Molex	22-04-1021	51191-0200	Series 50802

NOTE:
 A - 4 OFF FIXING HOLES ø3.96 TO ACCOMMODATE M3 SCREWS

Outline Drawing CUS150M/U (U Channel) Option

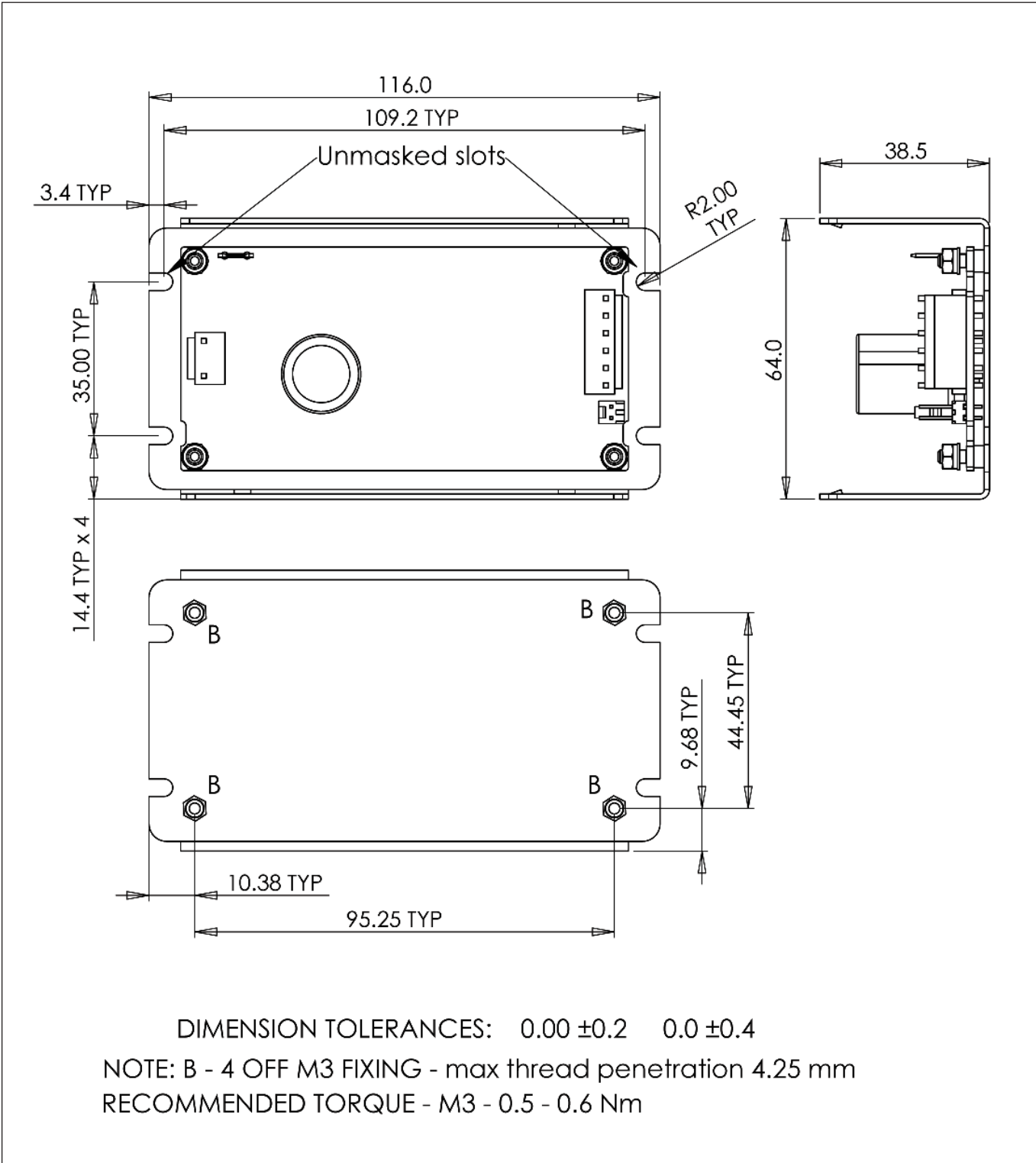

Outline Drawing CUS150M/B (Baseplate) Option

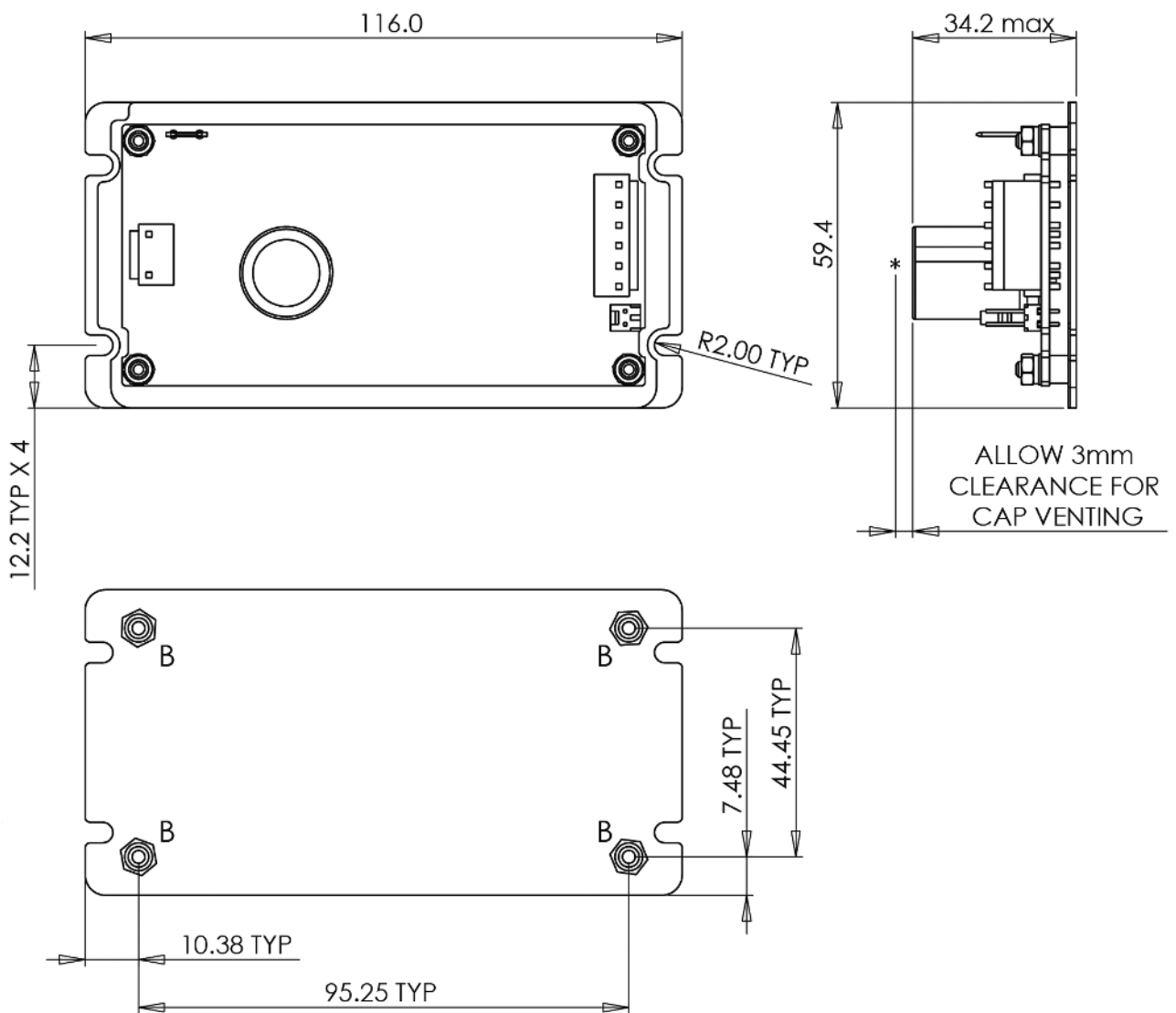

DIMENSION TOLERANCES: 0.00 ±0.2 0.0 ±0.4

NOTE: B - 4 OFF M3 FIXING - max thread penetration 4.25 mm

RECOMMENDED TORQUE - M3 - 0.5 - 0.6 Nm

Outline Drawing CUS150M/A (U Channel with Cover) Option

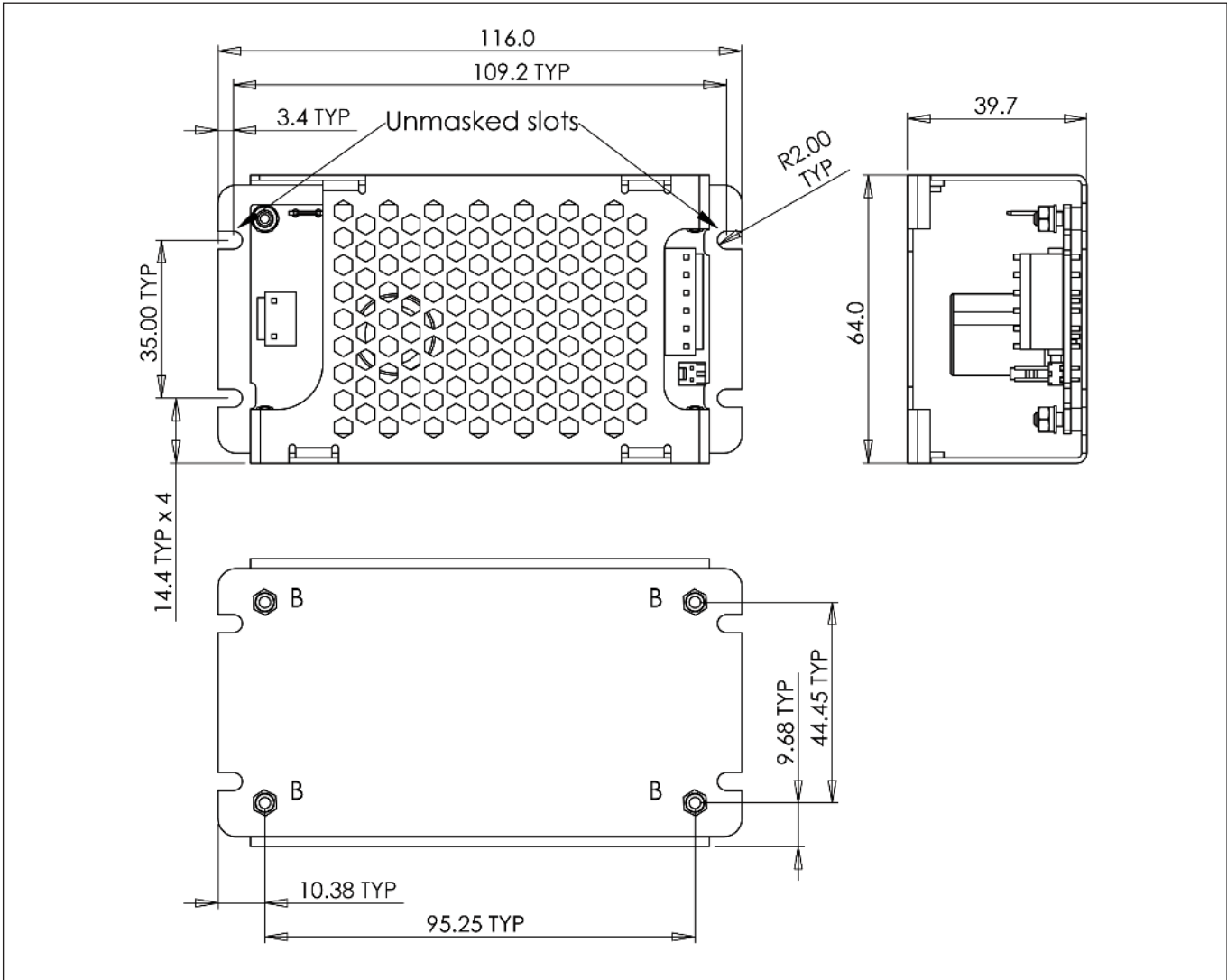

Outline Drawing CUS150M/F (U Channel with Cover & Top Mounted Fan) Option

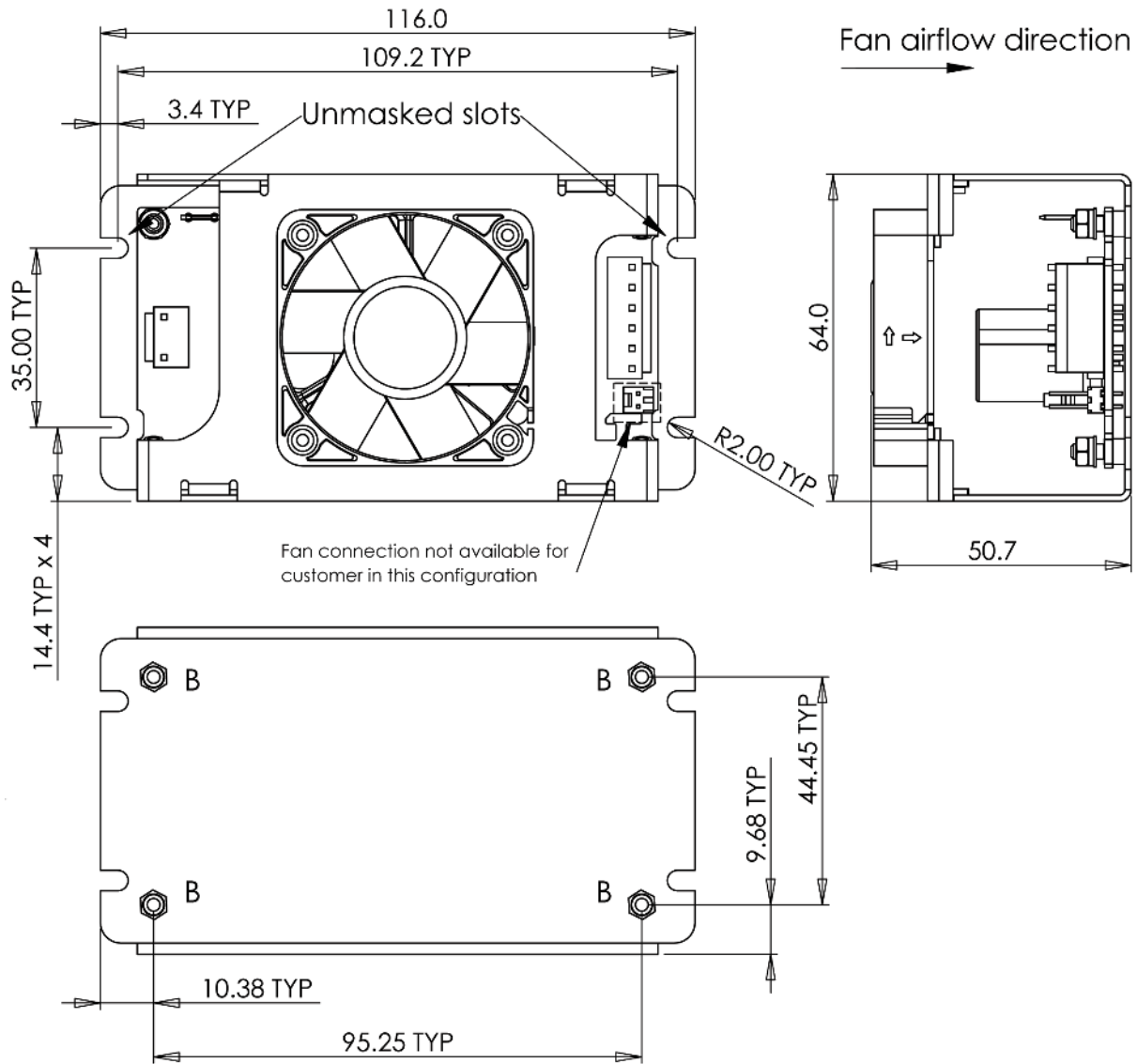

DIMENSION TOLERANCES: 0.00 ±0.2 0.0 ±0.4

NOTE: B - 4 OFF M3 FIXING - max thread penetration 4.25 mm

RECOMMENDED TORQUE - M3 - 0.5 - 0.6 Nm

Output Power vs Ambient Temperature (Open Frame & /B Units)

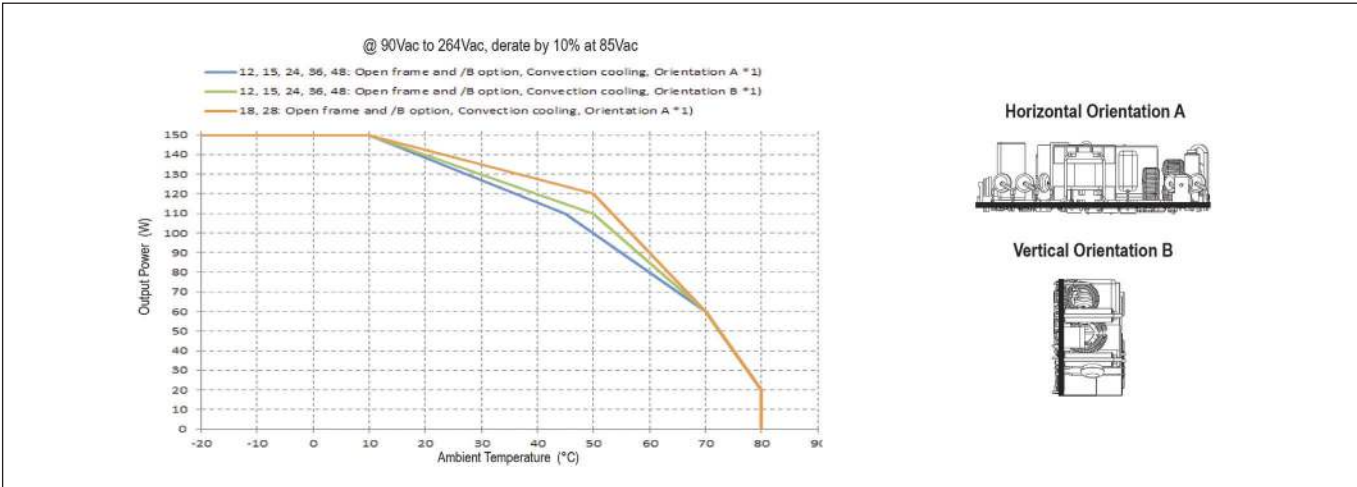

Note (*1) 50mm above surface, see instruction manual for maximum component temperatures.

Output Power vs Ambient Temperature (/U and /A versions)

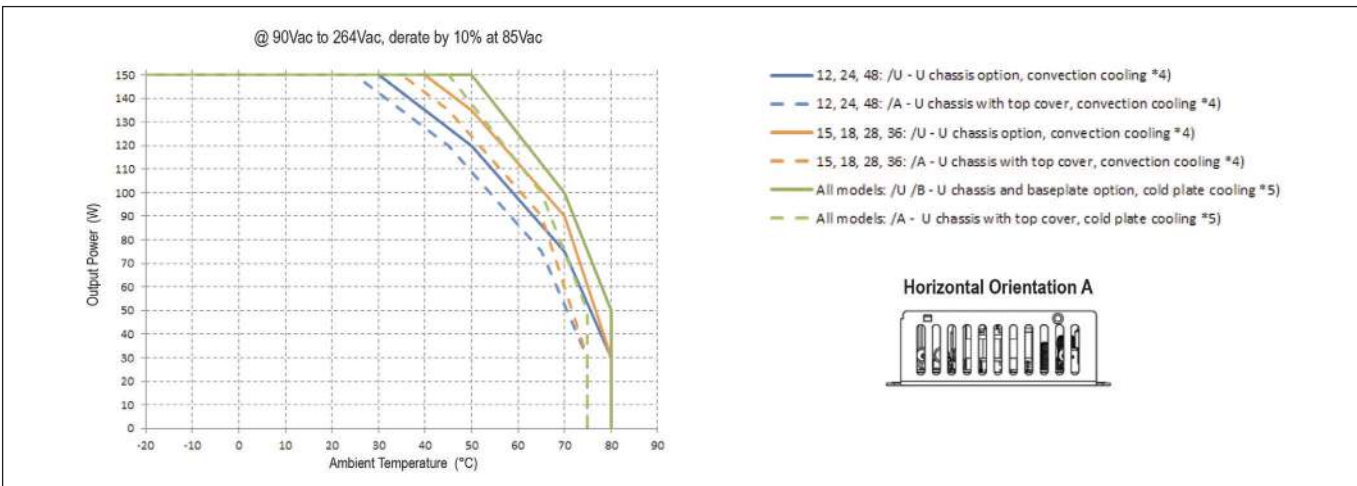

Note (*4) 50mm above surface, orientation A, no additional cold plate. See application note.

Note (*5) U chassis or Baseplate fixed on a cold plate (system chassis). See application note.

Output Power vs Ambient Temperature (/F version and Open Frame with Airflow)

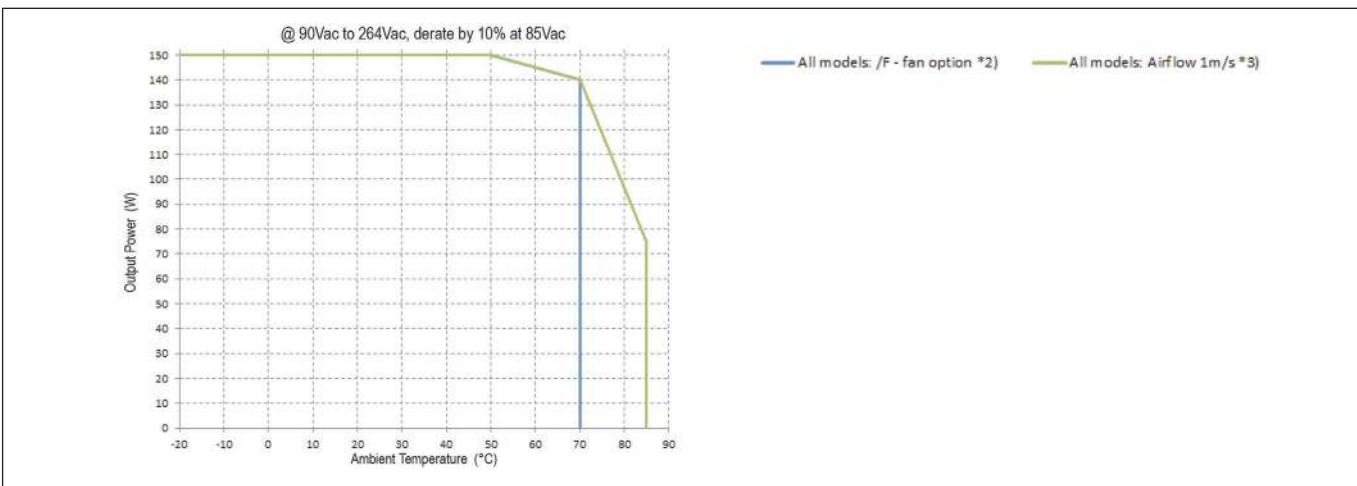

Note (*2) Limited by fan specification to maximum of 70°C. Note (*3) See application note.

CUS150M E-Cap Life vs Ambient Temperature

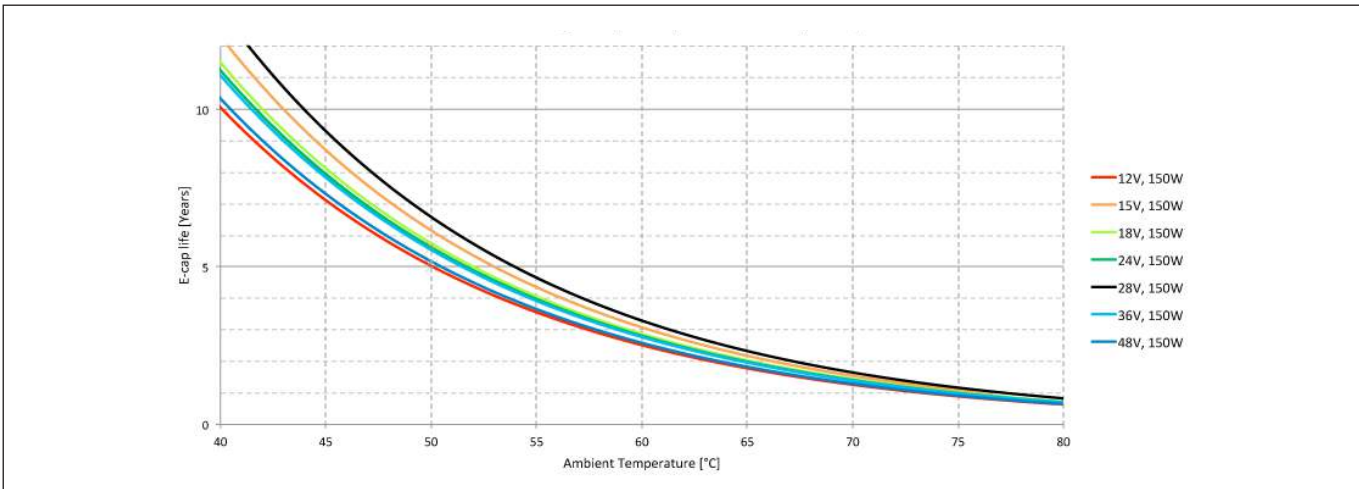

All models: Conduction cooling 150W, 100Vac, measured at 50°C, other points are calculated

CUS150M E-Cap Life vs Ambient Temperature 12V model: Additional Cooling Options

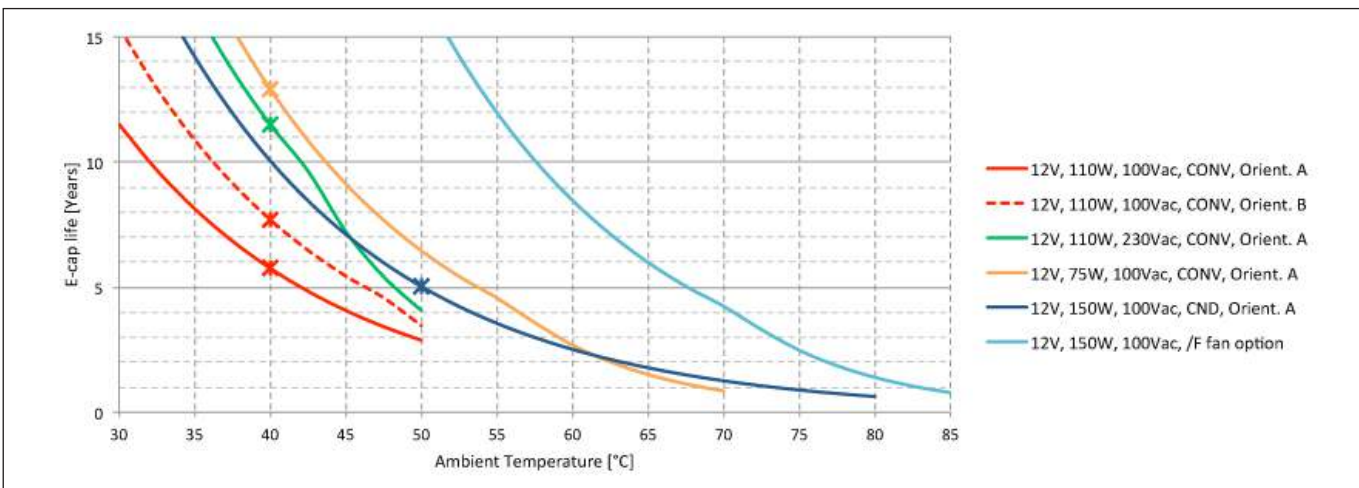

Notes: CONV: Convection Cooling, CND: Conduction Cooling

CUS150M E-Cap Life vs Ambient Temperature 12, 15, 24, 36, 48: conv 110W, 75W, 18, 28: conv 120W, 75W

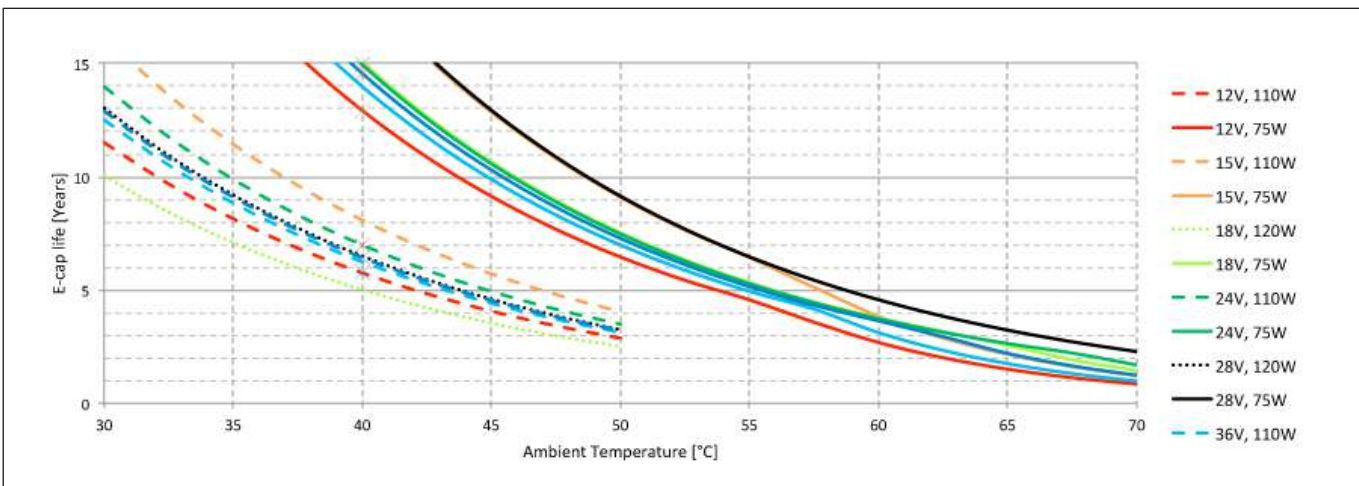

CUS150M Efficiency Graph

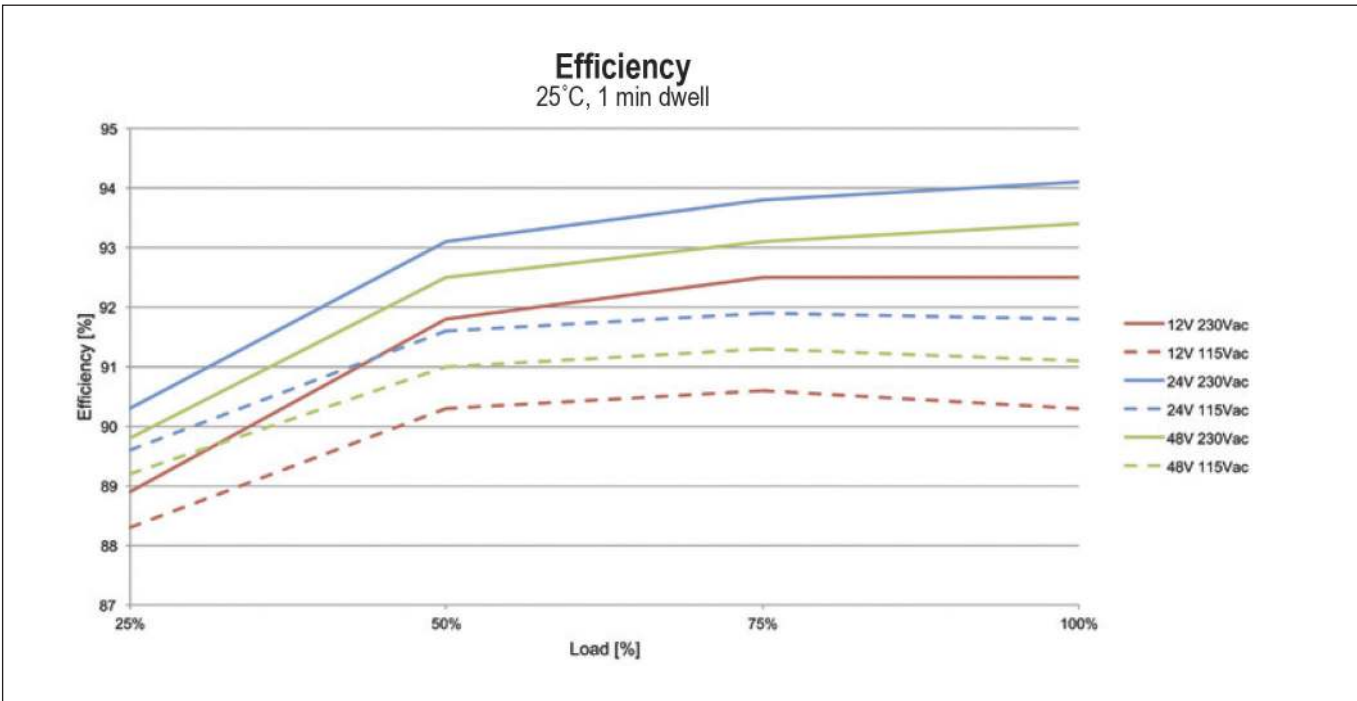

Critical component maximum allowable temperature table

Circuit reference	Description	Maximum temperature (°C)
1	Common mode choke	110 (130)
L2	PFC choke	125 (130)
L3	Differential mode choke	125 (130)
C1	Film capacitor	105
C2, C110	Electrolytic capacitors	86 (105)
C6, C102, C104, C105	Electrolytic capacitors	92 (105)
C3	X capacitor	100
C5, C100, C101, C103	Y capacitor	105
TX100	Transformer winding	110
XU101, XU102	Opto-coupler	100 (110)
XD8	Diode	130
J1	Input connector	105
J100	Output connector	105



TDK-Lambda France SAS

Tel: +33 1 60 12 71 65
france@fr.tdk-lambda.com
www.emea.lambda.tdk.com/fr



Italy Sales Office

Tel: +39 02 61 29 38 63
info.italia@it.tdk-lambda.com
www.emea.lambda.tdk.com/it



Netherlands

info@nl.tdk-lambda.com
www.emea.lambda.tdk.com/nl



TDK-Lambda Germany GmbH

Tel: +49 7841 666 0
info@de.tdk-lambda.com
www.emea.lambda.tdk.com/de



Austria Sales Office

Tel: +43 2256 655 84
info@at.tdk-lambda.com
www.emea.lambda.tdk.com/at



Switzerland Sales Office

Tel: +41 44 850 53 53
info@ch.tdk-lambda.com
www.emea.lambda.tdk.com/ch



Nordic Sales Office

Tel: +45 8853 8086
info@dk.tdk-lambda.com
www.emea.lambda.tdk.com/dk



TDK-Lambda UK Ltd.

Tel: +44 (0) 12 71 85 66 66
info@uk.tdk-lambda.com
www.emea.lambda.tdk.com/uk



TDK-Lambda Ltd.

Tel: +9 723 902 4333
info@tdk-lambda.co.il
www.emea.lambda.tdk.com/il



C.I.S.

Commercial Support:

Tel: +7 (495) 665 2627

Technical Support:

Tel: +7 (812) 658 0463
info@tdk-lambda.ru
www.emea.lambda.tdk.com/ru



TDK-Lambda Americas

Tel: +1 800-LAMBDA-4 or 1-800-526-2324
powersolutions@us.tdk-lambda.com
www.us.lambda.tdk.com



TDK Electronics do Brasil Ltda

Tel: +55 11 3289-9599
sales.br@tdk-electronics.tdk.com
www.tdk-electronics.tdk.com/en



TDK-Lambda Corporation

Tel: +81-3-6778-1113
www.jp.lambda.tdk.com



TDK-Lambda (China) Electronics Co. Ltd.

Tel: +86 21 6485-0777
powersolutions@cn.tdk-lambda.com
www.lambda.tdk.com.cn



TDK-Lambda Singapore Pte Ltd.

Tel: +65 6251 7211
tts.mkt@sg.tdk-lambda.com
www.sg.lambda.tdk.com



TDK India Private Limited, Power Supply Division

Tel: +91 80 4039-0660
mathew.philip@in.tdk-lambda.com
www.sg.lambda.tdk.com

