

ACPM-7700

Multiband Multimode PA Quad-Band GSM/EDGE and Multi Mode B1/B2/B3(B4)/B5/B8

Product Brief

Description

The ACPM- 7700 is a multiband, multimode PA (power amplifier) that supports GMSK and 8-PSK modulation schemes and UMTS bands 1, 2, 3(4), 5, and 8.

A directional coupler is integrated for UMTS PAs, and the isolation port is terminated internally.

Input and output terminals are internally matched to 50 ohms. The power amplifier is manufactured on an advanced InGaP HBT technology that offers state-of-the-art reliability, temperature stability, and ruggedness. This module is housed in a cost-effective, extremely small and thin 5 mm × 7 mm package.

Features

- Internal daisy-chain coupler
- Quad-band GSM/EDGE
- UMTS: three high band outputs and two low band outputs
- UMTS B1, B2, B3(B4), B5, and B8
- Small size (7 mm × 5 mm)
- APT compatible
- High efficiency with APT
- Compatible with MIPI RFFE
- Forty-two-pin surface mounting package
- Internal 50-ohm matching networks for both RF input and output
- Green – Lead-free and RoHS compliant

Application

- GSM850/900, DCS1800/PCS1900
- UMTS/LTE B1
- UMTS/LTE B2
- UMTS/LTE B3(B4)
- UMTS/LTE B5
- UMTS/LTE B8

Ordering Information

Part Number	Number of Devices	Container
ACPM-7700-TR1	1,000	178 mm (7 in.) tape/reel

Package Dimensions

The dimensions are in millimeters.

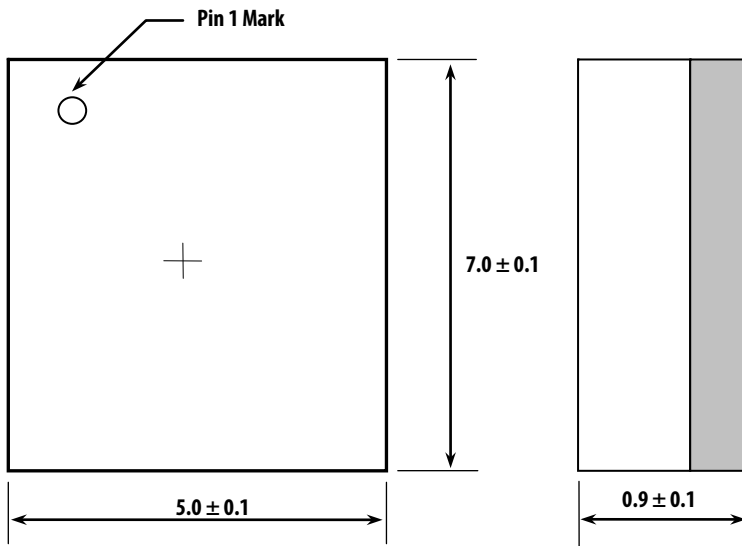

Marking Specification

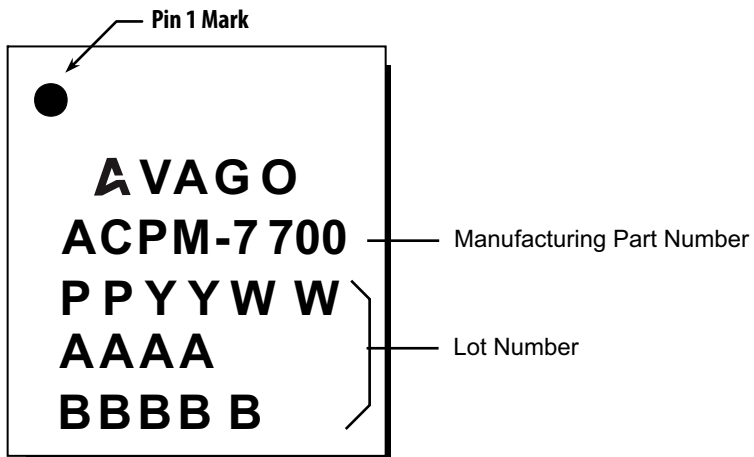

Pin Description

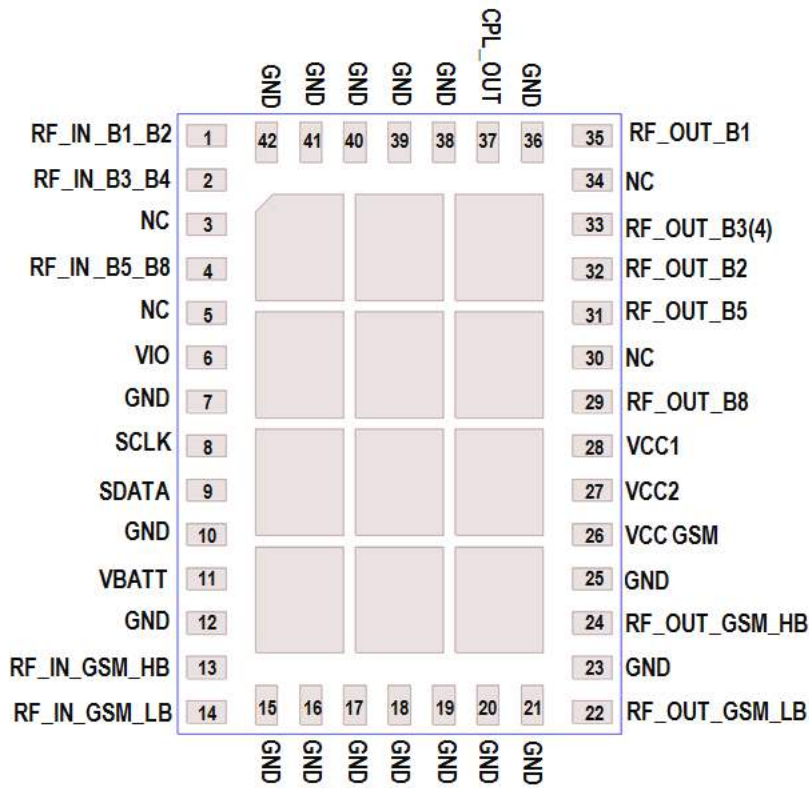

For product information and a complete list of distributors, please go to our web site:

www.avagotech.com

Avago, Avago Technologies, and the A logo are trademarks of Avago Technologies in the United States and other countries. All other brand and product names may be trademarks of their respective companies.

Data subject to change. Copyright © 2015 Avago Technologies. All Rights Reserved.

AV02-4876EN – 2015-03-24

