

RECOMMENDED PTH PATTERN
SCALE 1:1

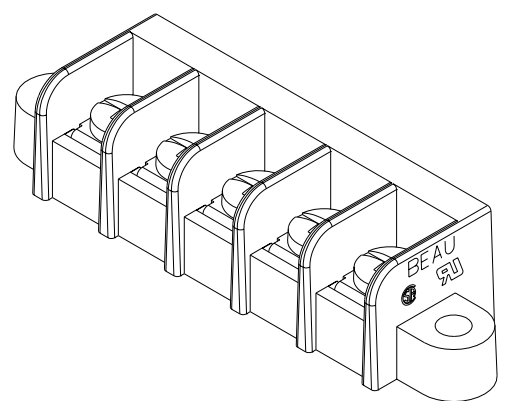

5 CIRCUIT SHOWN
Ø3.81 2 HOLES [.150]

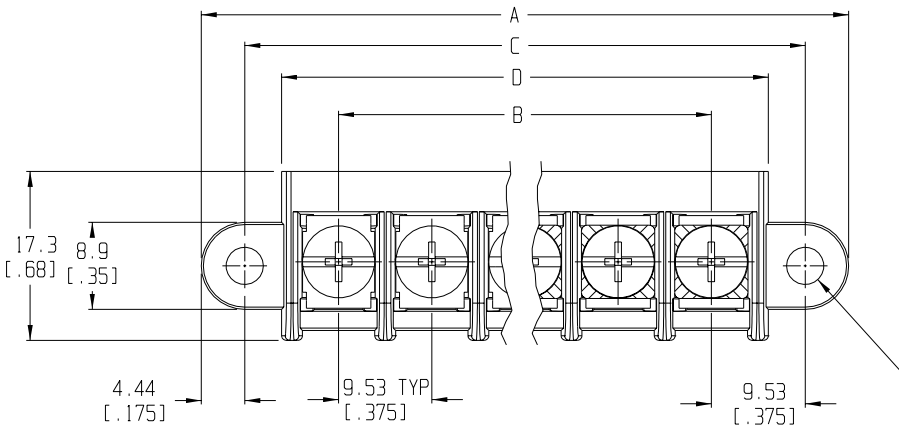
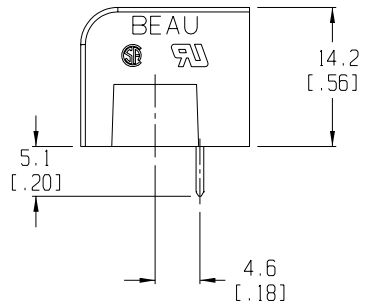
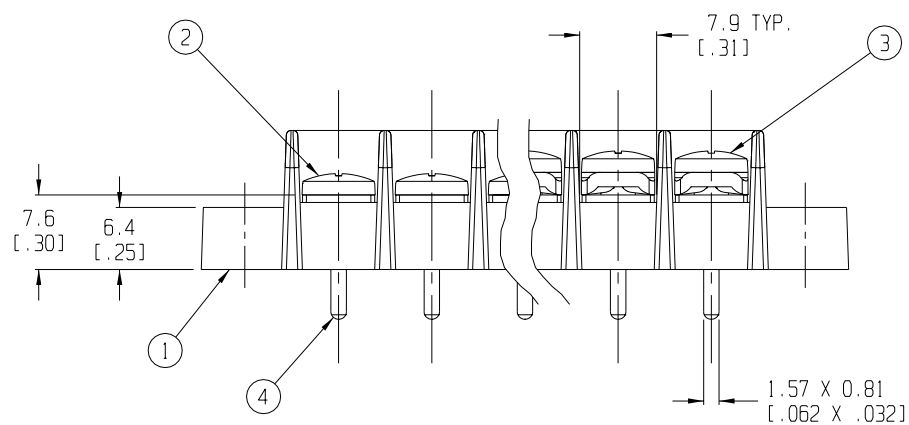

- NOTES:
1. MATERIAL: SEE TABLE
 2. FINISHES: SEE TABLE
 3. PRODUCT SPECIFICATION: UL & CSA, 12-24 AWG
 4. PACKAGING: NOT REQUIRED
 5. MATES WITH: NONE
 6. "XX" REFERS TO QTY. OF CIRCUITS
 7. LENGTH TABLE SHOWN ON SHEET 2
 8. REFER TO SD-38120-001 (-10A THRU -10D AND -11A THRU -11D) OR SD-38120-002 (-10AT THRU -10DT AND -11AT THRU -11DT) FOR OPTIONAL IMPRINTING.

ITEM	QTY.	DESCRIPTION	MATERIAL	FINISH
4	XX	TERMINAL	BRASS	TIN PLATE
3	XX	SCREW & WASHER (-50 OPT)	STEEL	ZINC CHROMATE
2	XX	SCREW (STD.)	STEEL	ZINC CHROMATE
1	1	BARRIER TERMINAL STRIP	THERMOPLASTIC	BLACK

EC NO. RELEASED DRWN: CLY CHK: APPR: REV A	DESCRIPTION MAJOR CRITICAL SPC	GENERAL TOLERANCES: (UNLESS SPECIFIED)	SCALE 2:1 DESIGN UNITS <input type="checkbox"/> mm <input checked="" type="checkbox"/> INCH	THIRD ANGLE PROJECTION	PROJECT NO. - DIMENSIONS: <input checked="" type="checkbox"/> mm <input type="checkbox"/> INCH <input type="checkbox"/> mm ONLY
		4 PLACES ±.0015 3 PLACES ±.038 ±.005 2 PLACES ±.13 ±.01 1 PLACE ±.3	DRAWN BY & DATE C. YORK 7-29-03	TITLE: SR BTS, PC TERMINAL	
		ANGULAR: ±2°	CHECKED BY & DATE APPROVED BY & DATE	MOLEX INCORPORATED	
		DRAFT WHERE APPLICABLE MUST REMAIN WITHIN DIMENSIONS	CAD FILENAME 755XX THIS DRAWING CONTAINS INFORMATION THAT IS PROPRIETARY TO MOLEX INCORPORATED AND SHOULD NOT BE USED WITHOUT WRITTEN PERMISSION.	MATERIAL NO. SEE SHEET 2 DRAWING NO. SD-38750-001 SHEET NO. 1 OF 2 SIZE B	

10	9	8	7	5	4	3	2	1
----	---	---	---	---	---	---	---	---

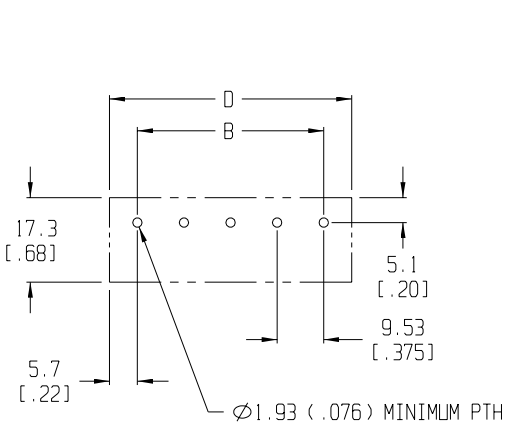

RECOMMENDED PTH PATTERN
SCALE 1:1

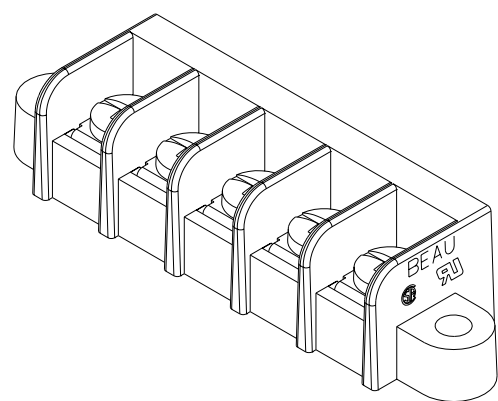
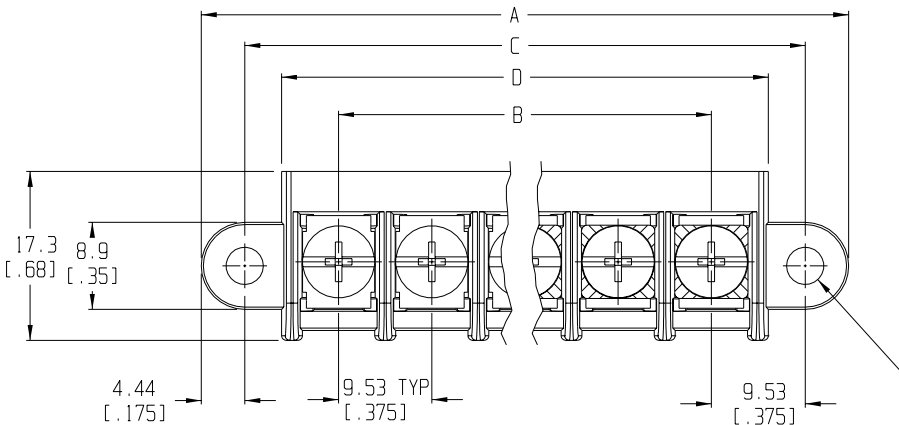

5 CIRCUIT SHOWN
Ø3.81 2 HOLES [.150]

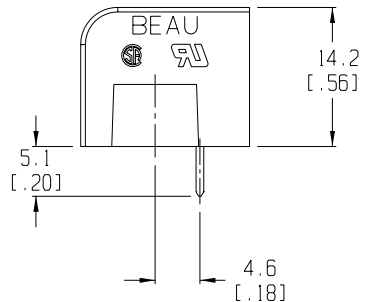
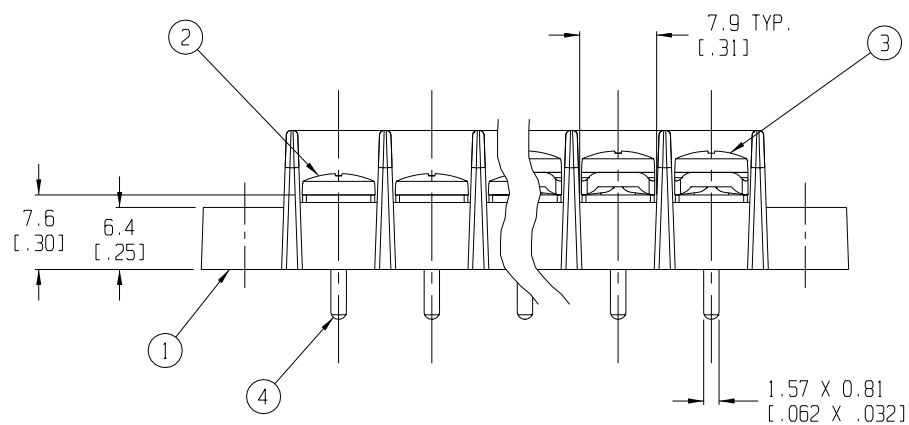

- NOTES:
1. MATERIAL: SEE TABLE
 2. FINISHES: SEE TABLE
 3. PRODUCT SPECIFICATION: UL & CSA, 12-24 AWG
 4. PACKAGING: NOT REQUIRED
 5. MATES WITH: NONE
 6. "XX" REFERS TO QTY. OF CIRCUITS
 7. LENGTH TABLE SHOWN ON SHEET 2
 8. REFER TO SD-38120-001 (-10A THRU -10D AND -11A THRU -11D) OR SD-38120-002 (-10AT THRU -10DT AND -11AT THRU -11DT) FOR OPTIONAL IMPRINTING.

ITEM	QTY.	DESCRIPTION	MATERIAL	FINISH
4	XX	TERMINAL	BRASS	TIN PLATE
3	XX	SCREW & WASHER (-50 OPT)	STEEL	ZINC CHROMATE
2	XX	SCREW (STD.)	STEEL	ZINC CHROMATE
1	1	BARRIER TERMINAL STRIP	THERMOPLASTIC	BLACK

EC NO. RELEASED
DRWN: CLY
CHK:
APPR:
REV A

QUALITY SYMBOLS
MAJOR =
CRITICAL =
SPC =

GENERAL TOLERANCES:
(UNLESS SPECIFIED)

	mm	INCH
4 PLACES	±.0015	±.005
3 PLACES	±.038	±.005
2 PLACES	±.13	±.01
1 PLACE	±.3	

ANGULAR: ±2°

DRAFT WHERE APPLICABLE MUST REMAIN WITHIN DIMENSIONS

SCALE 2:1
DESIGN UNITS
 mm INCH

THIRD ANGLE PROJECTION

PROJECT NO. -	I	-
DIMENSIONS:	SHT	REV
<input checked="" type="checkbox"/> mm <input type="checkbox"/> INCH	<input type="checkbox"/> mm <input type="checkbox"/> ONLY	REVISE ON CAD ONLY

TITLE: SR BTS, PC TERMINAL

MATERIAL NO. SEE SHEET 2
DRAWING NO. SD-38750-001
SHEET NO. 1 OF 2

THIS DRAWING CONTAINS INFORMATION THAT IS PROPRIETARY TO MOLEX INCORPORATED AND SHOULD NOT BE USED WITHOUT WRITTEN PERMISSION.

10	9	8	7	5	4	3	2	1
----	---	---	---	---	---	---	---	---